



Rittal Automation Systems

EN



Three things that belong together

All good things come in threes. Within the Alfra product family, we see our switch cabinet and control construction, steel and metal construction and magnet and lifting technology divisions as „triplets“ with individual characteristics, connected by the Alfra DNA. That is why we have once again united the trio in a compact catalogue

More proximity for new ideas

For you, this means the opportunity to browse through tool topics that do not directly concern your environment. Let us surprise and inspire you to application possibilities you would not have expected.

Do you want a shortcut?

Our new colour code system guides you through the product topics in the catalogue so that you can reach your goal in a flash even when searching for a specific device or tool. For a quick look at the hard facts, our overviews show the most important technical data in tabular form. Or would you prefer it „in writing?“ The short texts on our introductory pages provide you with concentrated information about the respective product groups – crisp, but not dry.

Something is moving

Would you like to see our Alfra application solutions in action right away? For selected tools and devices, you will find QR codes in the catalogue that will catapult you directly into the application video via your smartphone. More videos are available on our homepage www.alfra.de and on our social media accounts on Instagram, Facebook and LinkedIn.

We will be happy to help!

Do you like short distances? So do we. If you need advice on anything to do with our product worlds, our sales team is just a phone call away. Even we may not have the answer to all your questions – but will leave no stone unturned finding the person who will.

Telephone number head office: +49 6205 3051-0

Looking for someone to fulfil your every wish?

We don't want to put the „Fairy Godmother“ out of a job, but we do also fulfil a great many wishes – under realistic conditions, as determined by our technical department. Please see our catalogue for reference to the some of the many tailor-made products we provide. Feel free to get in touch with us!





APPLICATION SOLUTIONS FOR CONTROL CABINET AND CONTROL ENGINEERING



APPLICATION SOLUTIONS FOR STEEL AND METAL CONSTRUCTION



APPLICATION SOLUTIONS FOR MAGNETICS AND LIFTING TECHNOLOGY

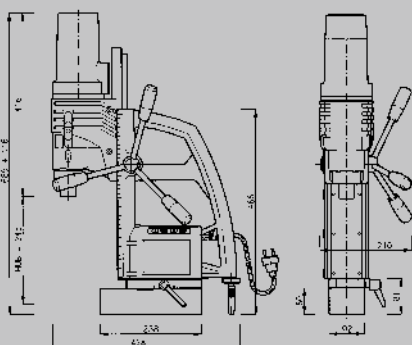

TECHNICAL INFORMATION

CONTENTS

Application solutions for Tools and machines for control engineering

MOBILE PUNCHING



**Hole punchers
MonoCut® / Sets**

Pages 10 - 11



**Split hole punchers
TriCut® / Sets**

Pages 12 - 13



**Split hole punchers
TriCut+® / Sets**

Pages 14 - 15



**Split hole punchers
FormCut®**

Pages 16 - 17



**Split hole punchers
FormCut+®**

Pages 18 - 19



Hole punchers Sanitary

Page 20

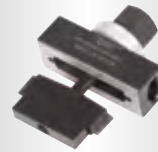

Hole punchers Sub-Min-D

Page 21



**Hole punchers special forms /
custom-made products**

Pages 22 - 23

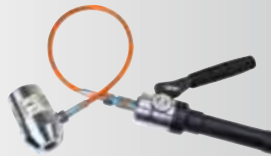

Manual hydraulic punchers / sets

Pages 24 - 32



Akku-Compact Flex®

Pages 30 - 31

PUMPS AND ACCESSORIES



Hydraulic pumps

Pages 33 - 36



Accessories / Notch pliers

Pages 37 - 39

CUTTING DEVICES FOR PROFILE RAILS AND WIRING DUCT

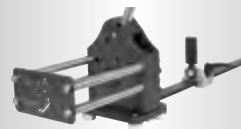

Cutting devices for Profile rails

Pages 40 - 47



Wiring duct cutting device

Pages 48 - 49

ASSEMBLY TABLES



Assembly tables AMT 150, AMTE 250

Pages 50 - 53

BUSBAR MACHINING



Busbar Machining

Pages 54 - 59

STATIONARY PUNCHING











ALFRA PRESS Stationary punching machines

Pages 60 - 75

CONTENTS

Application solutions for Steel and Metal Construction

DRILLING

 <p>Metal Core Drilling Machines Pages 76 - 99</p>			 <p>Metal Core Drilling Pages 100 - 101</p>	 <p>Accessories - Arbors Pages 102 - 103</p>	 <p>Accessories – Coolant Page 104</p>
 <p>Accessories – Tapping Attachments Page 105</p>	 <p>Chip Remover Page 106</p>	 <p>Vacuum Plate Page 107</p>	 <p>Core Drills HSS Pages 108 - 117</p>	 <p>Core Drills TCT Pages 118 - 123</p>	

CUTTING TOOLS



 <p>Hole Saws TCT Pages 124 - 134</p>	 <p>Hole Saws HSS-Bi-Metal/Sets Pages 135 - 138</p>	 <p>Multi-Step Drills Pages 139 - 140</p>	 <p>Milford Sabre Saw Blades Pages 141 - 142</p>
--	--	---	---

PUNCHING

 <p>Hydraulic Punching Pages 143 - 147</p>	 <p>Punches and punching dies Pages 148 - 149</p>	 <p>Hydraulic Pumps Pages 150 - 151</p>	 <p>Accessories – Service-Boy/APS Go Pages 152 - 153</p>
--	---	--	--

Application solutions for Magnetics and lifting technology

LIFTING

 <p>Load-lifting - Flat steel Pages 154 - 169</p>	 <p>Load-lifting - Round steel Pages 170 - 173</p>
---	--

POSITIONING AND FIXING

 <p>Positioning / Individualization Pages 174 - 176</p>	 <p>Angle fixing Page 177</p>
--	---

INTERESTING FACTS ABOUT TML/TMC

 <p>Interesting facts about TML/TMC Pages 179 - 182</p>

TECHNICAL INFORMATION

 <p>Technical information Pages 183 - 194</p>
--

APPLICATION SOLUTIONS FOR CONTROL CABINET AND CONTROL ENGINEERING

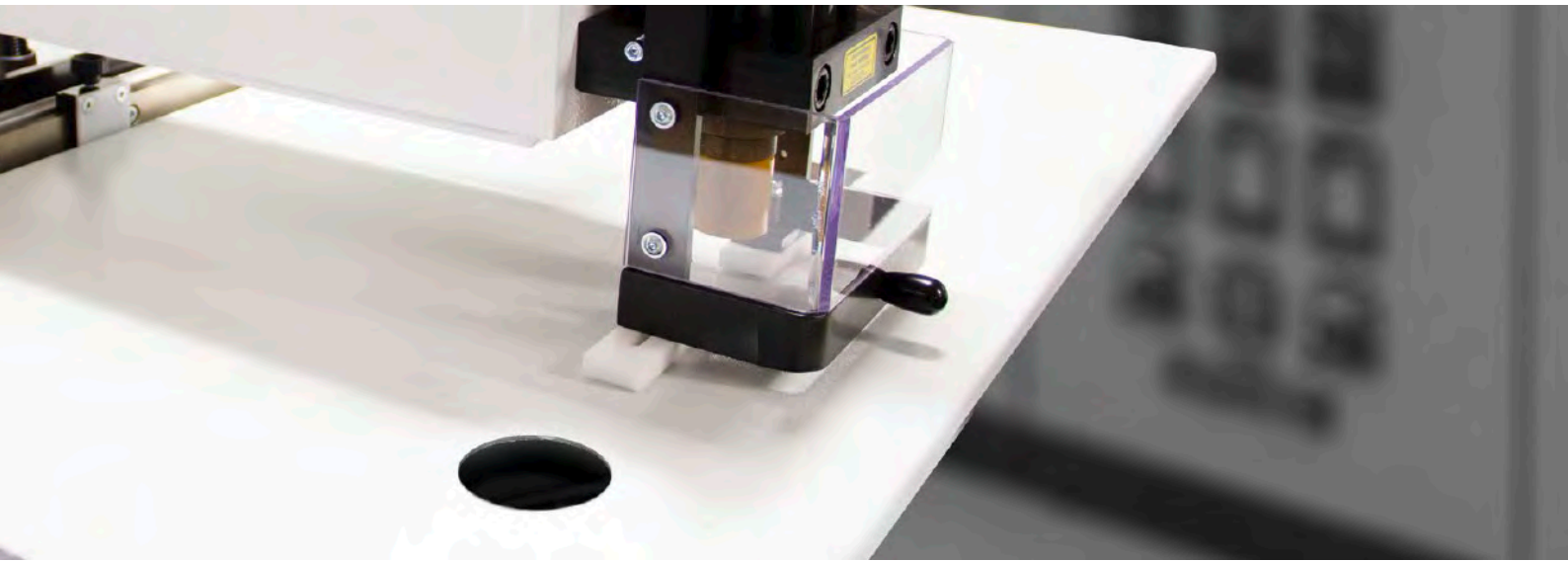

MOBILE PUNCHING

Showpiece pairs: Sheet metal punch and hand punch from Alfra



Sharp cutting geometry meets hydraulic power – a delightful connection. Alfra sheet metal punches convince as burr-free and low-noise alternative to saws. Using our hand punches, you can cut through housings faster and more efficiently than ever before.

- Sheet metal punches for round, square and rectangular punching
- Please do not hesitate to ask us about special products
- Hydraulic hand punches for the various working situations
- Depending on the model, they provide full performance regardless of whether they are in a fitted or small control cabinet

PUMPS AND ACCESSORIES

Our „extras“ ensure the complete punching experience



More power, tools for individual applications or devices for post-processing at the control cabinet? On the pages for pumps and accessories, you are bound to find what you need.

- The beating heart of the operation of your devices in the control cabinet: versatile hydraulic pumps with high output
- Notch grooves punched without filing in up to 2.0 mm thick sheet steel
- Extremely resilient: Alfra tension bolts and ball bearing screws
- Fits: technically sophisticated cylinder heads

PROFILE RAIL AND CABLE DUCT CUTTERS

Snip snip – clean cuts made easy



Switch cabinet builders are meticulous – and that's a good thing! To ensure that the millimetre-precise work on profile rails or wiring ducts is as accurate as it is convenient, our cutters are always the right choice

- Cut and perforate rails of almost all profiles burr-free with virtually no waste
- Low cutting clearance due to double rail guide
- Clean and safe cuts in wiring ducts
- Even with halogen-free models



ASSEMBLY TABLES

Four-star workstation for panel builders



The “customised workstation” is not just an empty phrase in our product range. The Alfa assembly tables AMT 150 and AMTE 250 are mobile and infinitely adjustable. This means they can be used exactly where they are needed and create space in the workshop at short notice if required. Assemble where and how you like – in your personal favourite working position.

- Hold mounting plates with dimensions up to 1100 mm x 1900 mm
- 4 swivel castors with total lock for safety and mobility
- Adjustable tilt angle from 0 - 80
- Optional roller conveyor for the installation of heavy mounting plates without lifting gear.

BUSBAR PROCESSING

Cutting, punching, bending: Precision equipment for the “nervous system” in the control cabinet



Without busbars, nothing works in the control cabinet. That’s why our cutting bending and punching equipment ensures that copper rails quickly, reliably and accurately are shaped according to the specifications in the construction plan. By simply inserting hole punches, various applications are possible with only one working cylinder.

- Bending and punching with one device
- Quick change of the punch for various applications with just a Working cylinder
- Waste-free cutting to length in seconds

STATIONARY PUNCHING



No pre-drilling – enclosure openings at the touch of a button.



Our Alfa press trio in white for effortless enclosure openings in enclosure housings and doors. Depending on the model, our stationary punches provide round, square and rectangular openings – without pre-drilling in just one work step.

- Depending on the model, for projections of up to 250 mm, 400 mm or 600 mm.
- Suitable for sheet steel, stainless steel, aluminium and plastics
- Please ask us about special designs for individual punching tools

ALFRA HOLE PUNCHERS® APPLICATION OVERVIEW

	FOR SHEET STEEL (S235)						FOR STAINLESS STEEL (VA)		
	 ALFRA HOLE PUNCHERS® MonoCut®		 ALFRA HOLE PUNCHERS® TriCut®		 ALFRA HOLE PUNCHERS® TriCut+®				
Material thickness when using									
Ø 6 mm draw bolt	-		1.5 mm		-				
Ø 9.5 mm draw bolt	2 mm		2 mm		-				
Ø 11.1 mm draw bolt	-		-		2 mm				
Ø 19 mm draw bolt	3 mm		3 mm		2.5 mm				
Diameter	12.7 mm M12 PG7	up to	152 mm	12.7 mm M12 PG7	up to	63.5 mm M63	15.2 mm PG9	up to	63.5 mm M63
custom-made products	✓		✓		✓				
Ø for predrilling									
Ø 6 mm draw bolt	-		6.2 mm		-				
Ø 9.5 mm draw bolt	11 mm		10 mm		-				
Ø 11.1 mm draw bolt	-		-		11.5 mm				
Ø 19 mm draw bolt	20.5 mm		19.5 mm		19.5 mm				
Ø 28.3 mm draw bolt	30.5 mm		-		-				
Machining possibilities using									
wrench or ratchet	✓ Up to Ø 89 mm		✓		✓				
Hydraulic drive	✓		✓		✓				

BALL BEARING SCREW

- 1 High-tensile bolts for the toughest operating conditions
- 2 Protrusion of ball bearing outside protective ring ensures perfect force transmission to wrench or punching tool
- 3 Ball bearings encapsulated in aluminium rings. Extremely long-life and perfectly protected against soiling
- 4 UNF fine thread

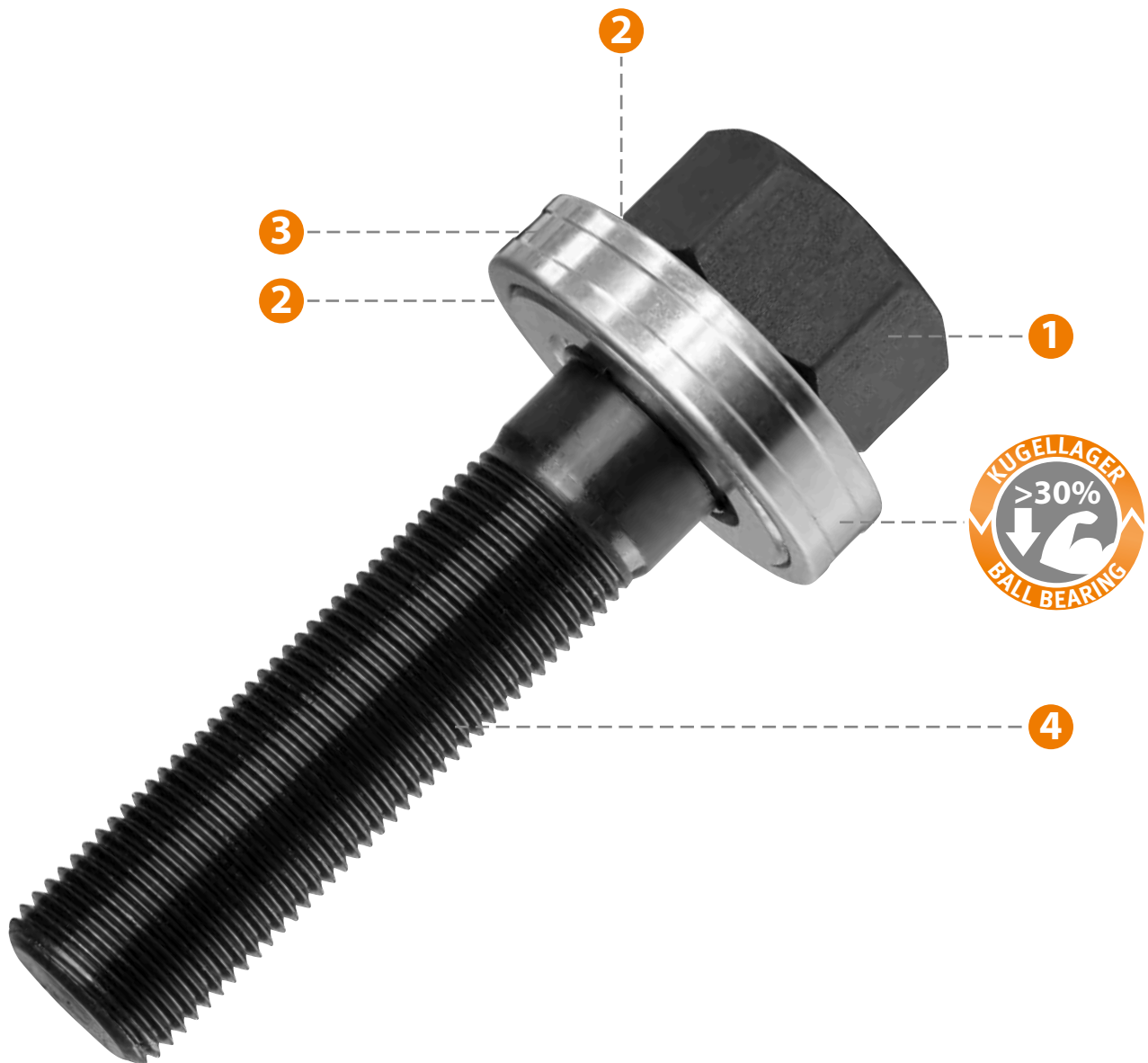

ALFRA HOLE PUNCHER® MONOCUT®



Hole puncher MonoCut® for sheet steel (S235)

- 1 With UNF fine thread
- 2 With 4 crosshair markings for simple, central alignment



“The max. material thickness for which a hole puncher can be used always depends on the screw and draw bolts used.”

Usable up to a material thickness of:

- 3.0 mm sheet steel with 3/4" (19.0 mm) screw or draw bolt
- 2.0 mm sheet steel with 3/8" (9.5 mm) screw or draw bolt

Hole puncher MonoCut® – sets



All sets are supplied in heavy-duty practical plastic cases.

Ø mm	12.7	15.2	16.2	18.6	19.0	20.4	22.5	25.4	28.3	30.5	31.7	32.5	34.6	37.0	38.0	40.5	43.2	47.0	49.6	50.5	54.0	60.0	61.5	63.5
Ø metric	M12	-	M16	-	-	M20	-	M25	-	-	-	M32	-	-	-	M40	-	-	-	M50	-	-	-	M63
Ø PG	7	9	-	11	-	13	16	-	21	-	-	-	-	29	-	-	-	36	-	-	42	48	-	-
Ø Inch	1/2"	-	-	-	3/4"	-	7/8"	1"	-	1-7/32"	1-1/4"	-	-	-	1-1/2"	-	1-11/16"	-	1-15/16"	-	2-1/8"	-	2-3/8"	2-1/2"
Ø Conduit	-	0.598	0.638	0.732	0.748	0.803	0.886	1.0	1.114	1.201	1.248	1.280	1.362	1.457	1.496	1.594	1.701	1.850	1.953	1.988	2.126	2.362	2.421	2.5

Prod.-No.	12.7	15.2	16.2	18.6	19.0	20.4	22.5	25.4	28.3	30.5	31.7	32.5	34.6	37.0	38.0	40.5	43.2	47.0	49.6	50.5	54.0	60.0	61.5	63.5
01290			•			•		•				•				•								
01291			•			•		•				•				•				•				•
01298	•	•		•		•	•		•	•				•					•			•	•	
01451		•		•		•	•		•															

+ 2 joint screws Ø 9.5 x 50.0 mm, 1 pre-drill HSS Ø 11.0 mm, 1 tube lubricating paste

ALFRA HOLE PUNCHER® MONOCUT®

Ø in mm	Max. Material thickness in mm (S235)	Size Metric	Size PG	Size Inch	Size Conduit & Pipe Size	Punches and dies		matching draw bolt	matching draw bolt	matching draw bolt with ball bearing	
						draw bolt with ball bearing	draw bolt				
Hole puncher MonoCut® – for sheet steel (S235)											
							Prod.-No.				
12,7	2,0	M 12	7	1/2"	0.500	-	01002	01001	02003	01335	01339
14,3	2,0	-	-	9/16"	0.563	-	01014	01013			
15,2	2,0	-	9	-	0.598	-	01006	01005			
16,0	2,0	-	-	-	0.630	-	01016	01015			
16,2	2,0	M 16	-	-	0.638	-	01010	01009			
18,6	2,0	-	11	-	0.732	-	01022	01021			
19,0	2,0	-	-	3/4"	0.748	-	01026	01025			
20,0	2,0	-	-	-	0.787	-	01030	01029			
20,4	2,0	M 20	13	-	0.803	-	01034	01033			
22,0	2,0	-	-	-	0.866	-	01042	01041			
22,5	2,0	-	16	7/8"	0.886	1/2"	01046	01045			
23,8	2,0	-	-	15/16"	0.937	-	01050	01049			
25,0	2,0	-	-	-	0.984	-	01054	01053			
25,4	2,0	M 25	-	1"	1.000	-	01058	01057			
27,0	2,0	-	-	1-1/16"	1.063	-	01078	01077			
28,3	2,0	-	21	-	1.114	3/4"	01070	01069			
28,3	3,0	-	21	-	1.114	3/4"	01074	01073			
30,1	2,0	-	-	-	1.185	-	01086	01085			
30,5	2,0	-	-	1-7/32"	1.201	-	01094	01093			
31,7	2,0	-	-	1-1/4"	1.248	-	01102	01101			
32,5	2,0	M 32	-	-	1.280	-	01106	01105			
34,6	3,0	-	-	1-11/32"	1.362	1"	01118	01117			
35,0	2,0	-	-	1-3/8"	1.378	-	01122	01121			
35,0	3,0	-	-	1-3/8"	1.378	-	01126	01125			
37,0	3,0	-	29	-	1.457	-	01130	01129			
38,0	3,0	-	-	1-1/2"	1.496	-	01134	01133			
40,5	3,0	M 40	-	-	1.594	-	01150	01149			
42,8	3,0	-	-	-	1.685	-	01158	01157			
43,2	3,0	-	-	1-11/16"	1.701	1 1/4"	01162	01161			
44,5	3,0	-	-	1-3/4"	1.752	-	01164	01163			
47,0	3,0	-	36	-	1.850	-	01166	01165			
49,6	3,0	-	-	1-15/16"	1.953	1 1/2"	01170	01169			
50,5	3,0	M 50	-	-	1.988	-	01178	01177			
54,0	3,0	-	42	2-1/8"	2.126	-	01190	01189			
60,0	3,0	-	48	-	2.362	-	01202	01201			
61,5	3,0	-	-	2-3/8"	2.421	2"	01206	01205			
63,5	3,0	M 63	-	2-1/2"	2.500	-	01210	01209			
Above Ø 68.0 mm we recommend the use of hydraulic equipment.											
68,0	3,0	-	-	-	2.677	-	01242	01241			
70,0	3,0	-	-	2-3/4"	2.756	-	01222	01221			
70,6	3,0	-	-	-	2.780	-	01220	01219			
74,0	3,0	-	-	2-7/8"	2.913	2 1/2"	01234	01233			
75,5	3,0	M 75	-	2-7/8"	2.972	-	01226	01225			
76,2	3,0	-	-	3"	3.000	-	01230	01229			
80,0	3,0	-	-	3-1/8"	3.150	-	01238	01237			
82,0	3,0	-	-	-	3.228	-	01246	01245			
Above 89.0 mm. the use of hydraulic equipment is generally required.									Required accessories:		
							Punch	Die	draw bolt	special draw bolt	counternut
89,0	3,0	-	-	3-1/2"	3.504	3"	01251	01252			
92,0	3,0	-	-	3-5/8"	3.622	-	01253	01254			
100,5	3,0	-	-	-	3.957	-	01257	01258			
115,5	3,0	-	-	4-1/2"	4.547	4"	01265	01266			
120,0	3,0	-	-	-	4.724	-	01267	01268			

ALFRA SPLIT HOLE PUNCHER TRICUT®

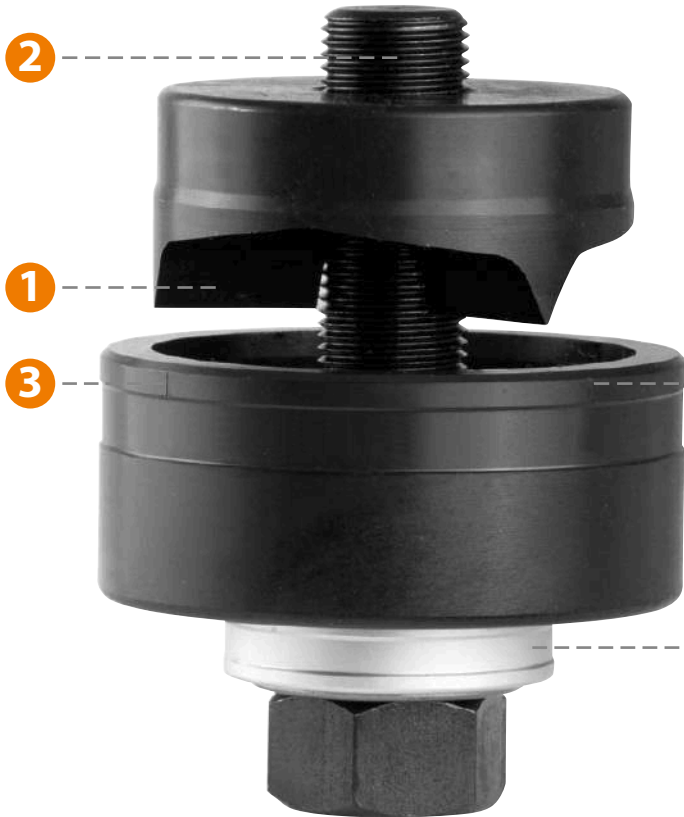

Split hole puncher TriCut® for sheet steel (S235)

- 1 With 3-fold split
- 2 With UNF fine thread
- 3 With 4 crosshair markings for simple, central alignment



"The max. material thickness for which a hole puncher can be used always depends on the screw and draw bolts used."

Usable up to a material thickness of:

- 3.0 mm sheet steel with 3/4" (19.0 mm) screw or draw bolt
- 2.0 mm sheet steel with 3/8" (9.5 mm) screw or draw bolt
- 1.5 mm steel sheet with M6 (6.0 mm) screw or draw bolt

Split hole puncher TriCut® - sets



All sets are supplied in heavy-duty practical plastic cases.

Ø mm	12.5	15.2	16.2	18.6	19.0	20.4	22.5	25.4	28.3	30.5	31.7	32.5	34.6	37.0	38.0	40.5	43.2	47.0	49.6	50.5	54.0	60.0	61.5	63.5	
Ø metric	M12	-	M 16	-	-	M 20	-	M 25	-	-	-	M 32	-	-	-	M 40	-	-	-	M 50	-	-	-	M 63	
Ø PG	7	9	-	11	-	13	16	-	21	-	-	-	-	29	-	-	-	36	-	-	42	48	-	-	
Ø Inch	1/2"	-	-	-	3/4"	-	7/8"	1"	-	1-7/32"	1-1/4"	-	-	-	1-1/2"	-	1-11/16"	-	1-15/16"	-	2-1/8"	-	2-3/8"	2-1/2"	
	0.5	0.598	0.638	0.732	0.748	0.803	0.886	1.0	1.114	1.201	1.248	1.280	1.362	1.457	1.496	1.594	1.701	1.850	1.953	1.988	2.126	2.362	2.421	2.5	
Ø Conduit	-	-	-	-	-	-	1/2"	-	3/4"	-	-	-	1"	-	-	-	1 1/4"	-	1 1/2"	-	-	-	2"	-	
Prod.-No.																									
01762			•			•		•				•				•									
01757			•			•		•				•				•				•				•	
01754	•		•			•		•				•				•									
	+ 1 ball bearing screw Ø 6.0 x 40.0 mm, 1 ball bearing screw Ø 9.5 x 50.0 mm, 1 ball bearing screw Ø 19.0 x 75.0 mm, 1 pre-drill HSS Ø 10.0 mm, 1 can lubricating paste																								
01755			•			•		•				•				•				•				•	
	+ 2 ball bearing screws Ø 9.5 x 50.0 mm, 1 ball bearing screw Ø 19.0 x 55.0 mm, 1 ball bearing screw Ø 19.0 x 75.0 mm, 1 pre-drill HSS Ø 10.0 mm, 1 can lubricating paste																								
01750		•		•		•		•		•		•				•									
	+ 2 ball bearing screws Ø 9.5 x 50.0 mm, 1 pre-drill HSS Ø 10.0 mm, 1 tube lubricating paste																								
01751		•		•		•		•		•		•				•					•		•		
	+ 2 ball bearing screws Ø 9.5 x 50.0 mm, 1 ball bearing screw Ø 19.0 x 55.0 mm, 1 ball bearing screw Ø 19.0 x 75.0 mm, 1 pre-drill HSS Ø 10.0 mm, 1 can lubricating paste																								

ALFRA SPLIT HOLE PUNCHER TRICUT®

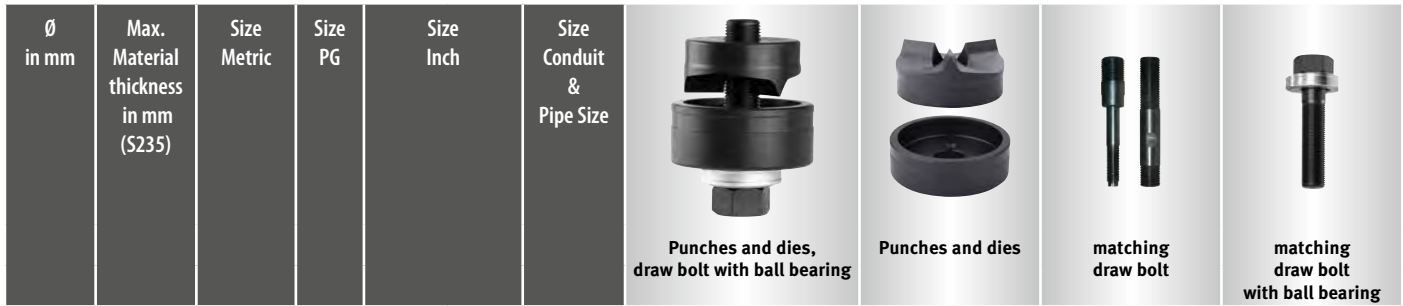

Split hole puncher TriCut® – for sheet steel (S235)

							Prod.-No.			
12.5	1.5	M 12	7	1/2"	0.500	-	01674	01770	02022	01334
15.2	2.0	-	9	-	0.598	-	01680	01771	02003	01339
16.2	2.0	M 16	-	-	0.638	-	01683	01772		
18.6	2.0	-	11	-	0.732	-	01686	01773		
20.4	2.0	M 20	13	-	0.803	-	01689	01774		
22.5	2.0	-	16	7/8"	0.886	1/2"	01692	01775		
25.4	2.0	M 25	-	1"	1.000	-	01695	01776		
28.3	2.0	-	21	-	1.114	3/4"	01698	01777		
28.3	3.0	-	21	-	1.114	3/4"	01701	01778	02002	01340
30.5	2.0	-	-	1-7/32"	1.201	-	01703	01779	02003	01339
32.5	3.0	M 32	-	-	1.280	-	01708	01780	02002	01340
34.6	3.0	-	-	1-11/32"	1.362	1"	01711	01788		
37.0	3.0	-	29	-	1.457	-	01713	01781		
40.5	3.0	M 40	-	-	1.594	-	01715	01782		
43.2	3.0	-	-	1-11/16"	1.701	1 1/4"	01718	01789		
47.0	3.0	-	36	-	1.850	-	01720	01783		
49.6	3.0	-	-	1-15/16"	1.953	1 1/2"	01723	01790		
50.5	3.0	M 50	-	-	1.988	-	01736	01784		
54.0	3.0	-	42	2-1/8"	2.126	-	01727	01785		
60.0	3.0	-	48	-	2.362	-	01729	01786		
61.5	3.0	-	-	2-3/8"	2.421	2"	01732	01791	01341	
63.5	3.0	M 63	-	2-1/2"	2.500	-	01739	01787		

ALFRA SPLIT HOLE PUNCHER TRICUT+®



Split hole puncher TriCut+® for sheet steel (S235) and stainless steel

- 1 With 3-fold split
- 2 With UNF fine thread
- 3 With 4 crosshair markings for simple, central alignment



“The max. material thickness for which a hole puncher can be used always depends on the screw and draw bolts used.”

Usable up to a material thickness of:

- 2.5 mm stainless steel with 3/4" (19.0 mm) screw or draw bolt
- 2.0 mm stainless steel with 7/16" (11.1 mm) screw or draw bolt

Split hole puncher TriCut+® - sets



All sets are supplied in heavy-duty practical plastic cases.

Ø mm	15.2	16.2	18.6	19.0	20.4	22.5	25.4	28.3	30.5	31.7	32.5	34.6	37.0	38.0	40.5	43.2	47.0	49.6	50.5	54.0	60.0	61.5	63.5
Ø metric	-	M 16	-	-	M 20	-	M 25	-	-	-	M 32	-	-	-	M 40	-	-	-	M 50	-	-	-	M 63
Ø PG	9	-	11	-	13	16	-	21	-	-	-	-	29	-	-	-	36	-	-	42	48	-	-
Ø Inch	-	-	-	3/4"	-	7/8"	1"	-	1-7/32"	1-1/4"	-	-	-	1-1/2"	-	1-11/16"	-	1-15/16"	-	2-1/8"	-	2-3/8"	2-1/2"
	0.598	0.638	0.732	0.748	0.803	0.886	1.0	1.114	1.201	1.248	1.280	1.362	1.457	1.496	1.594	1.701	1.850	1.953	1.988	2.126	2.362	2.421	2.5
Ø Conduit	-	-	-	-	-	1/2"	-	3/4"	-	-	-	1"	-	-	-	1 1/4"	-	1 1/2"	-	-	-	2"	-
Prod.-No.																							
01652		•			•		•				•				•								
01653		•			•		•				•				•				•				•
01645						•		•				•				•		•				•	

ALFRA SPLIT HOLE PUNCHER TRICUT+®

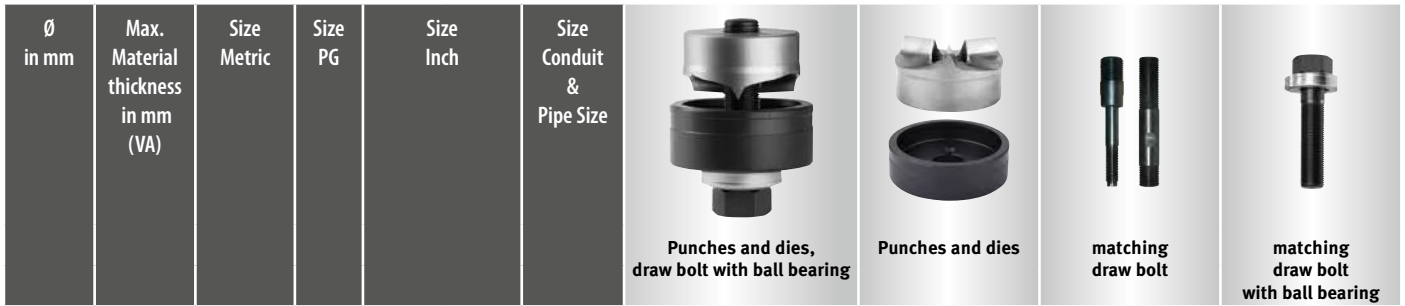

Split hole puncher TriCut+® – for sheet steel (S235) and stainless steel (VA)

							Prod.-No.			
15.2	2.0	-	9	-	0.598	-	01465	01600	02007	01342
16.2	2.0	M 16	-	-	0.638	-	01466	01656		
18.6	2.0	-	11	-	0.732	-	01467	01603		
20.4	2.0	M 20	13	-	0.803	-	01468	01606		
22.5	2.0	-	16	7/8"	0.886	1/2"	01469	01609		
25.4	2.5	M 25	-	1"	1.000	-	01470	01659		
28.3	2.5	-	21	-	1.114	3/4"	01471	01612	02002	01340
30.5	2.5	-	-	1-7/32"	1.201	-	01472	01615		
32.5	2.5	M 32	-	-	1.280	-	01473	01662		
34.6	2.5	-	-	1-11/32"	1.362	1"	01474	01618		
37.0	2.5	-	29	-	1.457	-	01475	01621		
40.5	2.5	M 40	-	-	1.594	-	01476	01665		
43.2	2.5	-	-	1-11/16"	1.701	1 1/4"	01477	01624		
47.0	2.5	-	36	-	1.850	-	01478	01627		
49.6	2.5	-	-	1-15/16"	1.953	1 1/2"	01479	01630		
50.5	2.5	M 50	-	-	1.988	-	01480	01668		
54.0	2.5	-	42	2-1/8"	2.126	-	01481	01633	01341	
60.0	2.5	-	48	-	2.362	-	01482	01636		
61.5	2.5	-	-	2-3/8"	2.421	2"	01483	01640		
63.5	2.5	M 63	-	2-1/2"	2.500	-	01484	01671		

ALFRA HOLE PUNCHER® FORMCUT®



Hole puncher FormCut® for sheet steel (S235)

- 1 With sideways puncher part ejection
- 2 With UNF fine thread
- 3 With 4 crosshair markings for simple, central alignment



“The max. material thickness at which a square or rectangular hole puncher (or even special tool) can be used always depends on the draw bolt and the cross-section of the tool (length x width or special shape).”

Hole puncher FormCut® – rectangular – for heavy plug connectors

4 centering mandrels are placed in the correct position at the die. When die and punch are pressed against each other, the drilling position gets marked on the adjacent work sheet. These 4 marks can be used as a drilling template.

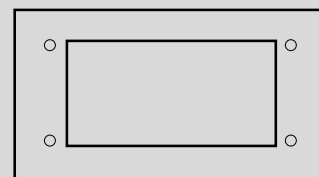

With the help of the twist drill, the drilling assembly for connectors can be done easily.

ALFRA HOLE PUNCHER® FORMCUT®

Size in mm	Max. Material thickness in mm (S235)	For use in	pre-drilling in mm	 incl. 1 - 4	1  draw bolt	2  counternut	3  Ball bearing pressure nut	4  Adapter for hydraulic
------------	--------------------------------------	------------	--------------------	--	--	---	--	--

Hole puncher FormCut® – square – for sheet steel (S235)

					Prod.-No.				
12,7 x 12,7	1,75	●	●	10	01300	01348	01355	01352	01353
15,8 x 15,8	1,75	●	●	10	01301				
19,0 x 19,0	2,0	●	●	14	01302	01347	01351	01359	01361
21,3 x 21,3	2,0	●	●	14	01371				
22,2 x 22,2	2,0	●	●	14	01303				
24,0 x 24,0	2,0	●	●	14	01331	01360	01350	01349	
25,4 x 25,4	2,0	●	●	17	01304				
45,5 x 45,5	3,0		●	20	01313	01345	01350		
46,0 x 46,0	3,0		●	20	01305				
50,8 x 50,8	3,0		●	24	01306	01344	01349		
68,0 x 68,0	3,0		●	24	01308				
92,0 x 92,0	3,0		●	30	01309	01343	01356		
125,0 x 125,0	3,0		●	30	01431				
138,0 x 138,0	2,5		●	30	01311				

Size in mm	Max. Material thickness in mm (S235)	Number of pins	For use in	pre-drilling in mm	 incl. 1 - 4	1  draw bolt	2  counternut or bridge	3  Ball bearing pressure nut	4  Adapter for hydraulic
------------	--------------------------------------	----------------	------------	--------------------	--	--	---	--	--

Hole puncher FormCut® – rectangular – for sheet steel (S235)

					Prod.-No.				
21,8 x 25,8	2,0		●	17	01318	01360	01351	01359	01361
22,0 x 30,0	2,0		●	17	01319				
22,0 x 42,0	2,0		●	17	01320	01345	01350		
22,0 x 45,0	2,0		●	17	01434				
22,2 x 45,0	2,0		●	17	01375				
25,0 x 50,0	2,0		●	17	01332		01418		
33,3 x 66,7	2,5		●	20	on request		01350		
45,0 x 92,0	2,5		●	24	01314	01344	01349		
46,0 x 92,0	2,5		●	24	01329				
68,0 x 138,0	3,0		●	30	on request	01343	01358		

Hole puncher FormCut® – rectangular – for heavy plug connectors (S235) – for sheet steel (S235)

36,0 x 52,0	2,5	6-polig		●	24	01325	01344	01350		
36,0 x 65,0	2,5	10-polig		●	24	01326				
36,0 x 86,0	2,5	16-polig		●	24	01327	01344	01349	01357	
36,0 x 91,0	2,5			●	24	01323				
36,0 x 112,0	2,0	24-polig		●	24	01328				
46,0 x 86,0	2,5			●	24	01322	01343	01349		
46,0 x 112,0	3,0			●	30	01324				

ALFRA HOLE PUNCHER® FORMCUT+®



Hole puncher FormCut+® for sheet steel (S235) and stainless steel

- 1 With sideways puncher part ejection
- 2 With UNF fine thread
- 3 With 4 crosshair markings for simple, central alignment



3

“The max. material thickness at which a square or rectangular hole puncher (or even special tool) can be used always depends on the draw bolt and the cross-section of the tool (length x width or special shape).”

Hole puncher FormCut+® – rectangular – for heavy plug connectors

4 centering mandrels are placed in the correct position at the die. When die and punch are pressed against each other, the drilling position gets marked on the adjacent work sheet. These 4 marks can be used as a drilling template.

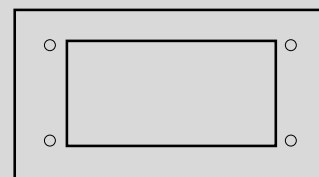

With the help of the twist drill, the drilling assembly for connectors can be done easily.

ALFRA HOLE PUNCHER® FORMCUT+®

Size in mm	Max. Material thickness in mm (VA)	For use in	pre-drilling in mm	 incl. 1 - 4	1  draw bolt	2  counternut	3  Ball bearing pressure nut	4  Adapter for hydraulic
------------	------------------------------------	------------	--------------------	--	--	---	--	--

Hole puncher FormCut+® – square – for sheet steel (S235) and stainless steel (VA)

					Prod.-No.				
12.7 x 12.7	1.25	●	●	10	on request	01348	01355		
15.8 x 15.8	1.25	●	●	10	on request				
19.0 x 19.0	1.5	●	●	14	013021			01352	01353
21.3 x 21.3	2.0	●	●	14	013711	01347	01351		
22.2 x 22.2	2.0	●	●	14	013031				
24.0 x 24.0	2.0	●	●	14	on request				
25.4 x 25.4	2.0	●	●	17	on request	01360		01359	01361
45.5 x 45.5	2.5		●	20	013131	01345	01350		
46.0 x 46.0	2.5		●	20	013051				
68.0 x 68.0	2.5		●	24	013081				
92.0 x 92.0	2.5		●	30	013091		01349		
125.0 x 125.0	2.0		●	30	014311	01343			
138.0 x 138.0	2.0		●	30	on request		01356		

Size in mm	Max. Material thickness in mm (VA)	Number of pins	For use in	pre-drilling in mm	 incl. 1 - 4	1  draw bolt	2  counternut or bridge	3  Ball bearing pressure nut	4  Adapter for hydraulic
------------	------------------------------------	----------------	------------	--------------------	--	--	---	--	--

Hole puncher FormCut+® – rectangular – for sheet steel (S235) and stainless steel (VA)

					Prod.-No.				
11.1 x 22.2	1.5		●	10	on request	01348	01355	01352	01353
22.0 x 30.0	2.0		●	17	on request				
22.0 x 42.0	2.0		●	17	013201				
22.2 x 45.0	2.0		●	17	on request				
25.0 x 50.0	2.0		●	17	on request		01418		
31.7 x 34.9	2.0		●	17	on request		01354		
33.3 x 66.7	2.0		●	20	on request	01345	01350		
45.0 x 92.0	2.0		●	24	013141				
46.0 x 92.0	2.0		●	24	013291	01344	01349		

Hole puncher FormCut+® – rectangular – for heavy plug connectors – for sheet steel (S235) and stainless steel (VA)

36.0 x 52.0	2.0	6-pins	●	24	013251				
36.0 x 65.0	2.0	10-pins	●	24	013261	01344	01350		
36.0 x 86.0	2.0	16-pins	●	24	013271				
36.0 x 91.0	2.0		●	24	on request		01349		
36.0 x 112.0	2.0	24-pins	●	30	013281	01343	01357		
46.0 x 86.0	2.0		●	30	013221	01344			
46.0 x 112.0	2.0		●	30	on request	01343	01349		

ALFRA HOLE PUNCHER® – SANITARY

- For punching out holes in washbasins

Size mm	Designation	Bolt size mm	Prod.-No.
Ø 28.3	Hole puncher complete	M 10 x 1	01293
Ø 31.7	Hole puncher complete	M 10 x 1	01294
Ø 35.0	Hole puncher complete	M 10 x 1	01295
Ø 37.0	Hole puncher complete	M 10 x 1	01292
	Draw bolt	M 10 x 1	01299



Prod.-No. 01450

Prod.-No.

01450

Hole puncher set - sanitary

In plastic case

Contents: 3 hole punchers 28.3 + 31.7 + 35.0 mm

3 draw bolts M 10.0 x 1

1 ring open-ended wrench 17

ALFRA DUAL HOLE PUNCHERS – SANITARY

- For punching out holes in washbasins

- Spanner actuation size 19 mm

Size mm	Designation	Bolt size mm	Prod.-No.
28 and 32	hole punchers complete	10 x 55 special	01456
32 and 35	hole punchers complete	10 x 55 special	01460
	Draw bolt	10 x 55 special	01457

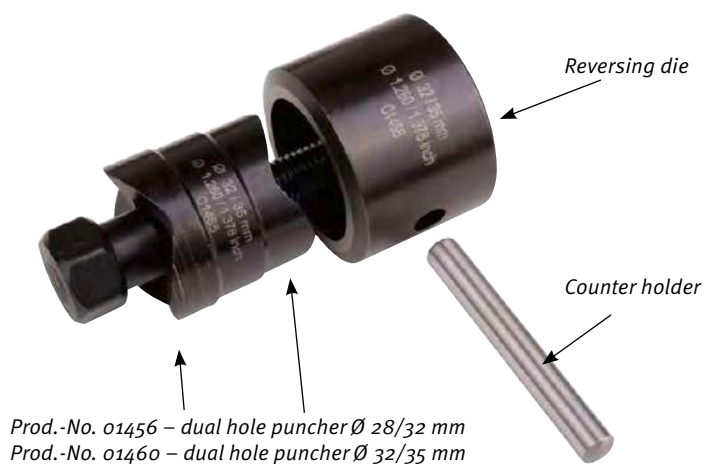

Prod.-No. 01456 – dual hole puncher Ø 28/32 mm

Prod.-No. 01460 – dual hole puncher Ø 32/35 mm

ALFRA HOLE PUNCHER® – SUB-MIN-D

- For “Sub-Min-D” multiple plug connectors – for sheet steel (S235) and stainless steel
- For punching out the cutout for 9-50-pins plug connectors. Anti-rotation axles for punches and dies are used as draw bolts.
- All hole punches are fitted with side ejection for the waste piece. No jamming in the die
- The hole punches are supplied in heavy duty, practical plastic cases



Prod.-No. 01369

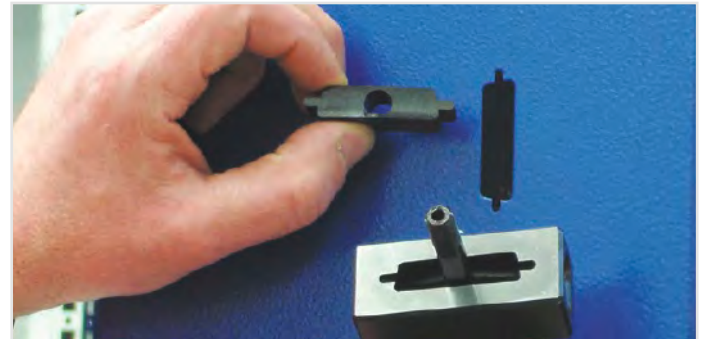
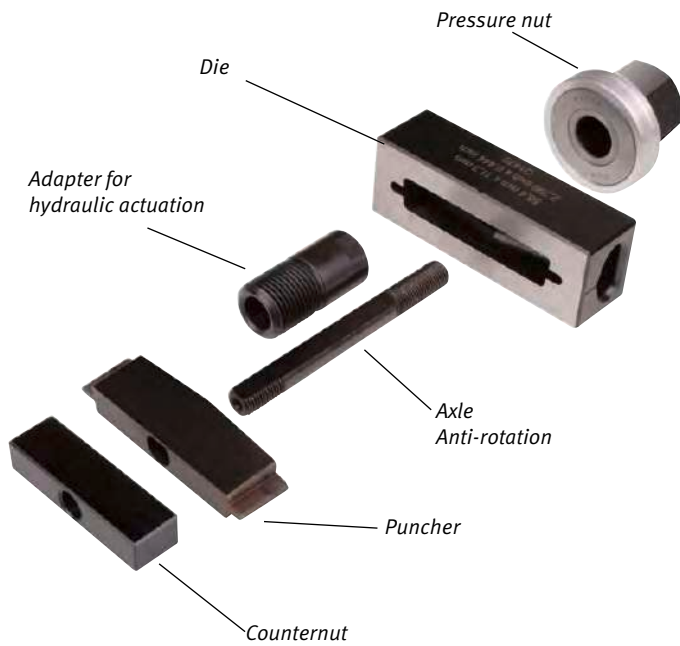

Size in mm	Max. Material thickness in mm (S235)/VA	Number of pins	For use in	pre-drilling in mm	incl. 1 - 4	1	2	3	4
			 						
						draw bolt	counternut or bridge	Ball bearing pressure nut	Adapter for hydraulic

Hole puncher Sub-Min-D – rectangular

						Prod.-No.				
19.8 x 11.3	2.0/1.5	9-pins	●	●	10	01366	01438	01442	01352	01353
28.2 x 11.3	2.0/1.5	15-pins	●	●	10	01367		01443		
41.9 x 11.3	1.75/1.25	25-pins	●	●	10	01368		01447		
58.4 x 11.3	1.75/1.25	37-pins	●	●	10	01369		01444		
55.7 x 13.9	1.65/1.0	50-pins	●	●	10	01370				





ALFRA HOLE PUNCHER® – SPECIAL FORMS

- All hole puncher are fitted with side ejection for the waste piece.
No jamming in the die
- The hole puncher are supplied in heavy duty, practical plastic cases



Size in mm	Max. Material thickness in mm (S235)	For use in	pre-drilling in mm					
		 		incl. 1 - 4	draw bolt	counternut or bridge	Ball bearing pressure nut	Adapter for hydraulic

Hole punchers special forms – for sheet steel (S235)

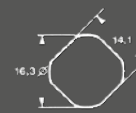
	Prod.-No.							
 Ø 22.5 with 3.2 mm lug	2.0	●	●	14	01420	01333		
 Ø 22.5 2-sided flattened to 18.5 mm	2.0	●	●	14	01421		01351	
 Ø 22.5 4-sided flattened to 20.1 mm	2.0	●	●	14	01422	01347		
 33.3 x 17.0 x 10.0 for profile cylinder	2.0	●	●	14	01423			
 Ø 16.3 4-sided flattened to 14.1 mm	1.75	●	●	11	01427	01348	01355	







Hole punchers special forms – for stainless steel (VA)

 Ø 22.5 with 3.2 mm lug	2.0	●	●	14	014201	01333	01351	01352	01353
---	-----	---	---	----	---------------	-------	-------	-------	-------

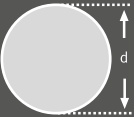
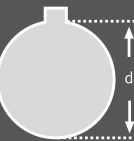
ALFRA HOLE PUNCHER® – CUSTOM-MADE PRODUCTS

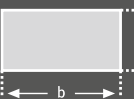
- We can make any form of circular, square, rectangular hole puncher to your drawings at short notice
- Please state whether your enquiry is for manual or hydraulic actuation in addition to the sheet thickness and material number
- Ask for our technical support

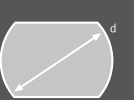
Hole puncher custom-made products

 <p>Circular</p>	Ø diameter d				Material thickness		Material type	
	mm				mm		Sheet steel (S235)	<input type="checkbox"/>
							Stainless steel (VA)	<input type="checkbox"/>
 <p>Circular with lugs</p>	Ø diameter d		Number of lugs	Lug width	Material thickness		Material type	
	mm			mm		mm		Sheet steel (S235)
							Stainless steel (VA)	<input type="checkbox"/>
 <p>Square</p>	Edge length a				Material thickness		Material type	
	mm				mm		Sheet steel (S235)	<input type="checkbox"/>
							Stainless steel (VA)	<input type="checkbox"/>
 <p>Rectangle</p>	Width b		Height h		Material thickness		Material type	
	mm		mm		mm		Sheet steel (S235)	<input type="checkbox"/>
							Stainless steel (VA)	<input type="checkbox"/>
 <p>Circular flattened on one side</p>	Ø diameter d		Flattened to		Material thickness		Material type	
	mm		mm		mm		Sheet steel (S235)	<input type="checkbox"/>
							Stainless steel (VA)	<input type="checkbox"/>
 <p>Circular flattened on two sides</p>	Ø diameter d		Flattened to		Material thickness		Material type	
	mm		mm		mm		Sheet steel (S235)	<input type="checkbox"/>
							Stainless steel (VA)	<input type="checkbox"/>
 <p>Square with 4 flattened corners</p>	Edge length a		Corners flattened to		Material thickness		Material type	
	mm		mm		mm		Sheet steel (S235)	<input type="checkbox"/>
							Stainless steel (VA)	<input type="checkbox"/>

ALFRA HYDRAULIC MANUAL PUNCHERS

OUR HANDY ONES MAKE THE BREAKTHROUGH - BURR-FREE
AND FOR ALL SHEET METAL PUNCH SHAPES





“Cutting out housings for connectors, switches or cable connections is one of the daily tasks in control cabinet construction.... In order for the cutting geometry of the tool to be ideally used, either muscle power or a hydraulic alternative must generate the necessary Newtons. Hand punches are a convenient option to manual operation by lag screw. Particularly when a user has to cope with a high number of openings on the control cabinet, the specialised devices make the process easier.”

Published in “Schaltschrankbau”
3/2022

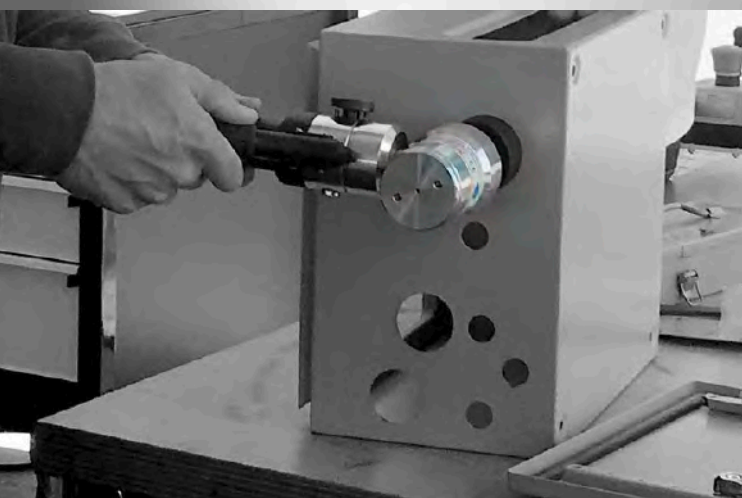

PDF



	 ALFRA COMPACT®	 ALFRA COMPACT COMBI®	 ALFRA COMPACT FLEX®	 ALFRA AKKU-COMPACT FLEX®
Page	26 - 27	28 - 29	32	30 - 31
Prod.-No.	02001	02050	02065	02082
Punching Circular holes	up to 82 mm Ø 3.0 mm sheet steel (S235), 2.0 mm stainless steel (F = 600 N/mm ²)			
	89 - 152 mm Ø (with special draw bolt and spacer sleeve) 2.0 mm sheet steel (S235), 1.5 mm stainless steel (F = 600 N/mm ²)			
Punching Shaped holes	68 x 68 mm 3.0 mm sheet steel (S235), 2.0 mm stainless steel (F = 600 N/mm ²)			
	92 x 92 mm (with special draw bolt and spacer sleeve) 2.0 mm sheet steel (S235), 1.5 mm stainless steel (F = 600 N/mm ²)			
Punching force	75 kN	75 kN	75 kN	75 kN
Hydraulic pressure max.	680 bar	680 bar	680 bar	680 bar
Piston stroke	18 mm	18 mm	18 mm	18 mm
Tool mounting	19 mm	19 mm	19 mm	19 mm
Hydraulic hose length	-	-	600 mm	600 mm
Hydraulic medium	HLP32 hydraulic oil	HLP32 hydraulic oil	HLP32 hydraulic oil	HLP32 hydraulic oil
Weight	1.45 kg	1.75 kg	1.97 kg	2.5 kg with Battery

COMPACT® MANUAL PUNCHER STRAIGHT

Compact® manual puncher straight - our classic

How does the hole get into the sheet? With 75 kN of concentrated punching force! The Alfa basic model from the hydraulic ALFRA hand punch line is a lightweight with bite. Weighing just 1.45 kg, it becomes an invaluable helper in combination with all types of

sheet metal punching machines when a particularly large number of openings or unusual material thicknesses have to be handled every day in control cabinet and control system construction.

- 1 Precisely tuned pressure relief valve protects against damage to the cylinder
- 2 Reinforced, comfortable soft-touch handle to prevent slipping
- 3 Heavy-duty aluminium design for reduced weight at just 1.45 kg
- 4 Roller-finished, particularly smooth cylinder running surfaces protect against wear – even under heavy loads
- 5 High punching force 75 kN



COMPACT® MANUAL PUNCHER STRAIGHT – SETS



Ø mm	15.2	16.2	18.6	20.4	22.5	25.4	28.3	32.5	37	40.5	47	50.5	54	60	63.5
Ø metric	-	M 16	-	M 20	-	M 25	-	M 32	-	M 40	-	M 50	-	-	M 63
Ø PG	9	-	11	13	16	-	21	-	29	-	36	-	42	48	-
Ø Inch					7/8"	1"							2-1/8"		2-1/2"
	0.598	0.638	0.732	0.803	0.886	1.000	1.114	1.280	1.457	1.594	1.850	1.988	2.126	2.362	2.500

Prod.-No.

Set MonoCut® – for sheet steel (S235):

1 Compact® manual puncher straight / MonoCut® punches and dies / 1 draw bolt Ø 19 mm / 1 draw bolt Ø 19 x 9.5 mm / 1 HSS pre-drill Ø 11 mm / 1 spacer sleeve set (3-part)

	02006	•		•	•	•			•		•		•		
--	--------------	---	--	---	---	---	--	--	---	--	---	--	---	--	--

Set TriCut® – for sheet steel (S235):

1 Compact® manual puncher straight / TriCut® punches and dies / 1 draw bolt Ø 19 mm / 1 draw bolt Ø 19 x 9.5 mm / 1 HSS pre-drill Ø 10 mm / 1 spacer sleeve set (3-part)

	01752	•		•	•	•			•		•		•	•	
	01765		•		•			•		•					
	01758		•		•			•		•		•			•

Set TriCut+® – for sheet steel (S235) and stainless steel sheeting:

1 Compact® manual puncher straight / TriCut+® punches and dies / 1 draw bolt Ø 19 mm / 1 draw bolt Ø 19 x 11.1 mm / 1 HSS pre-drill Ø 11.5 mm / 1 spacer sleeve set (3-part)

	01650	•		•	•	•			•		•		•		
	01642		•		•			•		•					
	01654		•		•			•		•		•			•

Compact® manual puncher straight:

1 Compact® manual puncher straight / 1 draw bolt Ø 19 mm / 1 draw bolt Ø 19 x 9.5 mm / 1 HSS pre-drill Ø 11 mm / 1 spacer sleeve set (3-part)

	02001	without punches and dies													
--	--------------	--------------------------	--	--	--	--	--	--	--	--	--	--	--	--	--

COMPACT COMBI® MANUAL PUNCHER 90°

Compact Combi® manual puncher 90° - our articulated one

If you are mobile, you can quickly adapt to unusual conditions. This also applies to our Compact Combi®, with a head that can be rotated through 90 degrees. Is it getting tight in the control cabi-

net or is another work situation making it difficult to use a manual punch? No problem, because our “articulated one” can overcome even these challenges.

- 1 Movable punching head for effortless positioning
- 2 Precisely tuned pressure relief valve protects against damage to the cylinder
- 3 Reinforced, comfortable soft-touch handle to prevent slipping
- 4 Heavy-duty aluminium design for reduced weight at just 1.75 kg
- 5 Roller-finished, particularly smooth cylinder running surfaces protect against wear – even under heavy loads
- 6 High punching force 75 kN



COMPACT COMBI® MANUAL PUNCHER 90° – SETS



Ø mm	12,7	15,2	16,2	18,6	20,4	22,5	25,4	28,3	32,5	37	40,5	47	50,5	54	60	63,5
Ø metric	M 12	-	M 16	-	M 20	-	M 25	-	M 32	-	M 40	-	M 50	-	-	M 63
Ø PG	7	9	-	11	13	16	-	21	-	29	-	36	-	42	48	-
Ø Inch						7/8"	1"							2-1/8"		2-1/2"
	0.5	0.598	0.638	0.732	0.803	0.886	1.000	1.114	1.280	1.457	1.594	1.850	1.988	2.126	2.362	2.500

Prod.-No.

Set MonoCut® – for sheet steel (S235):

1 CompactCombi® manual puncher 90° / MonoCut® punches and dies / 1 draw bolt Ø 19 mm / 1 draw bolt Ø 19 x 9,5 mm / 1 HSS pre-drill Ø 11 mm / 1 spacer sleeve set (3-part)

	02052	•	•	•	•	•		•		•		•		•	•	
--	--------------	---	---	---	---	---	--	---	--	---	--	---	--	---	---	--

Set TriCut® – for sheet steel (S235):

1 CompactCombi® manual puncher 90° / TriCut® punches and dies / 1 draw bolt Ø 19 mm / 1 draw bolt Ø 19 x 9,5 mm / 1 HSS pre-drill Ø 10 mm / 1 spacer sleeve set (3-part)

	01753		•		•	•	•		•		•		•		•	•
	01766			•		•		•		•						
	01759			•		•		•		•		•				•

Set TriCut+® – for sheet steel (S235) and stainless steel sheeting:

1 CompactCombi® manual puncher 90° / TriCut+® punches and dies / 1 draw bolt Ø 19 mm / 1 draw bolt Ø 19 x 11,1 mm / 1 HSS pre-drill Ø 11,5 mm / 1 spacer sleeve set (3-part)

	01651		•		•	•	•		•		•		•		•	
	01643			•		•		•		•						
	01655			•		•		•		•		•				•

Compact Combi® manual puncher 90°:

1 Compact Combi® manual puncher 90° / 1 draw bolt Ø 19 mm / 1 draw bolt Ø 19 x 9,5 mm / 1 HSS pre-drill Ø 11 mm / 1 spacer sleeve set (3-part)

	02050	without punches and dies														
--	--------------	--------------------------	--	--	--	--	--	--	--	--	--	--	--	--	--	--

AKKU-COMPACT FLEX®

Akku-Compact Flex® - our triathlete

Power, agility, endurance – the Akku-Compact Flex® shines in all three disciplines with top marks. Just like its “sister” the ALFRA Compact Flex®, this punch shows its full potential as a safe alternative to the saw in a narrow or crowded control cabinet. Why? It does not produce any chips, thereby reducing the risk of

short circuits. Its trademark? Its powerful rechargeable battery, which is ready for use again just 30 minutes after being fully discharged – ideally suited for a high number of punches in a short time.

- 1 High-pressure hose with kink protection, prevents damage to the inside of the cabinet due to sudden pressure on the kinked hose
- 2 Pressure sensor with auto-detection of punch-through; punch cannot damage the die after the punching process
- 3 Battery ready for use again after 30 minutes even after full discharge
- 4 Heavy-duty aluminium design for less weight of only 2.5 kg including battery
- 5 Roller-finished, particularly smooth cylinder running surfaces protect against wear – even under heavy loads
- 6 High punching force 75 kN



▶ VIDEO

AKKU-COMPACT FLEX®

Practical manual hydraulics with 18 V LiON battery for punching circular, square and rectangular cutouts in control cabinet and switch gear construction. Extremely easy to handle and light thanks to high-tensile aluminium head.

- Light and easy to handle, only 2.5 kg including battery

Technical data:

Drive

Max. punching force: 75 kN
Max. hydraulic pressure: 680 bar

Battery

18 V Li-Ion / 1.5 Ah
Charging time: 30 mins. after full discharge
Use: -10° - +40° C

Battery charger

Charges all batteries 18-28 V, compatible for NiCD, NiMH and Li-Ion batteries. Automatic temperature monitoring. Battery cell overcharging is prevented by switchover from rapid charging to trickle charging. The charging state is shown by the LED display. The PCB is completely enclosed.

Punching capacity with 1.5 Ah battery

195 x Ø 22.5 mm	MonoCut®	to 2.5 mm S235
165 x Ø 22.5 mm	TriCut®	to 2.5 mm S235
105 x Ø 63.5 mm	MonoCut®	to 2.5 mm S235
65 x Ø 63.5 mm	TriCut®	to 2.5 mm S235

Weight

2.5 kg including battery



Prod.-No. 02082

Scope of delivery:

ALFRA Akku-Compact Flex® manual hydraulics with 1 battery 18 V, charger 18 - 28 V
Draw bolts – 9.5 x 19 mm – Prod.-No. 02003
Draw bolts – 19 x 120 mm – Prod.-No. 02002
Spacer sleeve set 3-part – Prod.-No. 02004
Pre-drill 11 mm Ø – Prod.-No. 08023
in heavy duty, practical plastic case

Prod.-No.

02082

Spare parts:

Replacement battery
Battery charger 220 V - 240 V
Special draw bolt for square holes 92 x 92 mm
Special draw bolt for round holes 89 - 152 mm
Special spacer sleeve

Prod.-No.

02082-01.2.0

02082-03

01395

01398L

01396



Prod.-No. 02082-03



Prod.-No. 02082-01.2.0



Prod.-No. 02082

COMPACT FLEX® HAND HYDRAULICS

Compact Flex® - our artist

When it comes to flexibility, our ALFRA Compact Flex® is the artist among hand punches. What's so special about it? Its elastic high-pressure hose for positioning the punch head even under the most challenging of conditions. Thanks to this flexible connection between the body and the head of the device, the

punch can always be positioned exactly where it is needed. For example, near the edges of the housing. With 75 kN punching force at a dead weight of just 2 kg, the ALFRA Compact Flex® is a lightweight power pack that is compatible with all types of sheet metal punch.

- 1 Elastic hydraulic hose for almost unlimited applications, e.g. in the equipped control cabinet with limited space conditions
- 2 Precisely tuned pressure relief valve protects against damage to the cylinder
- 3 Reinforced, comfortable soft-touch handle to prevent slipping
- 4 Balanced transmission ratio in the hydraulics for power-saving application
- 5 Heavy-duty aluminium design for reduced weight at just 2 kg
- 6 Roller-finished, particularly smooth cylinder running surfaces protect against wear – even under heavy loads
- 7 High punching force 75 kN

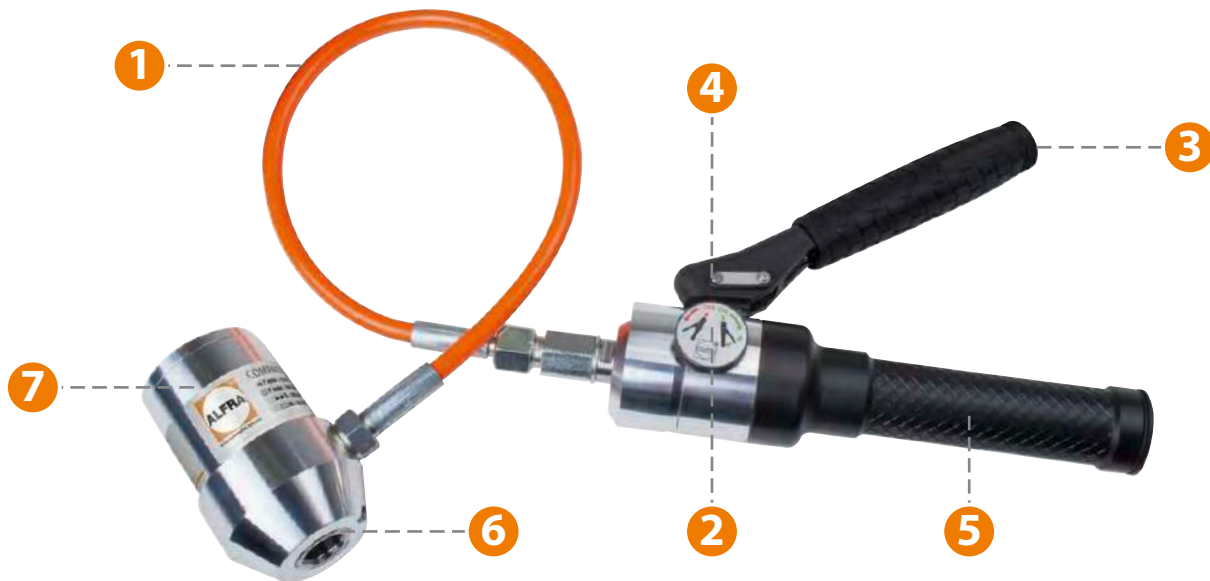

Punching capacity

Punching force:	75 kN
Operating pressure max.:	680 bar
Hydraulic hose length:	600 mm
Weight:	2.0 kg











Scope of delivery:

- 1 Compact Flex® manual hydraulic punch
- 1 draw bolt Ø 19.0
- 1 draw bolt Ø 19.0 x 9.5 mm
- 1 HSS pre-drill Ø 11.0 mm
- 1 spacer sleeve set 3-part

Compact Flex® manual hydraulics
in heavy duty, practical plastic case

Prod.-No.
02065

PUMP SUMMARY

<p>Recommended combination ■ ■</p> <p>Possible combination ■</p>	 AHP-M1 in combination with footswitch Prod.-No. 03862.NG	 AHP-S	 LHP 700	 FOOT PUMP
Prod.-No.	03857	03854	02140	02121
 Prod.-No. 02012 / 02013 Page 38	■	■ ■	■	■ ■
 Prod.-No. 03200SET.NG Page 56	■ ■			
 Prod.-No. 03250.L Page 58	■ ■			
 Prod.-No. 03258 Page 59	■ ■	■	■	■
 Prod.-No. 03003 Page 47		■ ■		
 Prod.-No. 03170 Page 62		■ ■		■
 Prod.-No. 03195 Page 63		■ ■		■

ALFRA ELECTRO-HYDRAULIC PUMP AHP S

Technical data:

Max. pressure:	700 bar
Max. flow rate:	0.58 l/min
Oil type:	HLP 46
Filling volume:	3.2 l
Working volume:	2.2 l
Weight:	27 kg
Voltage / frequency:	230 V / 50 Hz
Power:	0.75 kW
Current consumption:	3.26 A
Motor speed:	2,800 rpm



Prod.-No.

Electro-hydraulic pump AHP S
incl. hand switch and hydraulic hose 2.00 m
(Prod.-No. 03859)

03854

Accessories

Optional foot switch 2-pedal

03866

ALFRA ELECTRO-HYDRAULIC PUMP AHP M1



Technical data:

Max. pressure:	700 bar
Max. flow rate:	1.1 l/min
Oil type:	HLP 46
Filling volume:	3.2 l
Working volume:	2.2 l
Weight:	29 kg
Operating voltage:	230 V / 50 Hz
Power:	1.3 kW
Current consumption:	5.7 A
Motor speed:	2,860 rpm

Prod.-No.

Electro-hydraulic pump AHP M1
incl. hydraulic hose 2.00 m

03857

Accessories

Foot switch with safety function
(accessories necessary for operation)

03862.NG

Hydraulic hose for AHP M1
with control cable

2.00 m

03856

Hydraulic hose for AHP M1
without control cable

3.00 m

03858



Prod.-No. 03862.NG Foot switch

ALFRA FOOT PUMP

- Max. operating pressure 700 bar
- Fitted pressure limiting valve
- For all circular, square, rectangular and special shape hole punches
- The foot pump leaves both hands free for precise positioning and punching on the control cabinet. The foot pump carrying frame is splayed. This guarantees steady working with no risk of tipping

Tank volume: 270 cm³
 Usable oil volume: 210 cm³
 Delivery volume: 1.7 cm³ per piston stroke

Contents: 1 hydraulic cylinder with quick coupling
 1 hydraulic hose 2.8 m
 1 draw bolt Ø 19.0 and 19.0 x 9.5 mm
 1 spacer sleeve set 5-part
 1 pre-drill Ø 11.0 mm

	Prod.-No.
Set foot pump with hydraulic cylinder and accessories	02120
Foot pump only, with 2.8 m hydraulic hose	02121



Prod.-No. 02120



FOOT SWITCH OVERVIEW

		Foot switch				
Prod.-No.		03861	03862.NG	03863	03865	03866
Used for Prod.-No.	03200SET		03857		03200SET	03855
			03250.L	03855		
	03980		03200SET.NG		03855	03854

ALFRA AIR-HYDRAULIC PUMP – LHP 700

Air-hydraulic pump for the operation of single-action hydraulic cylinders for hole punchers, cable cutters, presses or similar applications.

- Heavy-duty tank
- Tank venting filter
- Reduced noise levels
- Oil level indicator on tank
- Precise start-up under load possible
- Precise activation - the drain valve activated by the foot pedal allows precise lowering of the load.
- Hydraulic hose 2.0 m with quick coupling

Technical data

max. operating pressure: (at a feed line pressure of 7 bar)	700 bar
Feed pressure/working range:	2.8 - 10 bar
Air connection:	1/4" thread
Flow rate depressurised:	1.0 l/min
Flow rate p max. (with 7 bar air):	0.1 l/min
Tank volume:	2.4 l
Usable oil volume:	2.1 l
Weight:	6.3 kg



Prod.-No. 02140

Prod.-No.

02140

Air-hydraulic pump

ACCESSORY PARTS – DRAW BOLTS, BALL BEARING SCREWS

	Size in inch	Size in mm	Prod.-No.
Draw bolt	-	6.0	02024
Adapter	-	19.0 / 6.0	02023
Draw bolt compl.	-	19.0 / 6.0	02022
Draw bolt	3/8"	9.5	02009
Adapter	3/4" / 3/8"	19.0 / 9.5	01353
Draw bolt compl.	3/4" / 3/8"	19.0 / 9.5	02003
Draw bolt	3/4" / 3/8"	19.0 / 9.5*	02010
Draw bolt	7/16"	11.1	01424
Adapter	3/4" / 7/16"	19.0 / 11.1	01425
Draw bolt compl.	3/4" / 7/16"	19.0 / 11.1	02007
Draw bolt	3/4" / 7/16"	19.0 / 11.1*	02011
Draw bolt	3/4"	19.0 x 120	02002
Draw bolt	3/4"	19.0 x 55	01337

* draw bolts made of high-alloy tool steel for higher loading

	Ø x l in inch	Ø x l in mm	Prod.-No.
Draw bolt with ball bearing	-	6.0 x 46 mm	01334
Draw bolt with ball bearing	3/8" x 2"	9.5 x 50 mm	01339
Draw bolt with ball bearing	3/4" x 2-3/16"	19.0 x 55 mm	01340
Draw bolt with ball bearing	7/16" x 2-3/8"	11.1 x 60 mm	01342
Draw bolt with ball bearing	3/4" x 2-15/16"	19.0 x 75 mm	01341

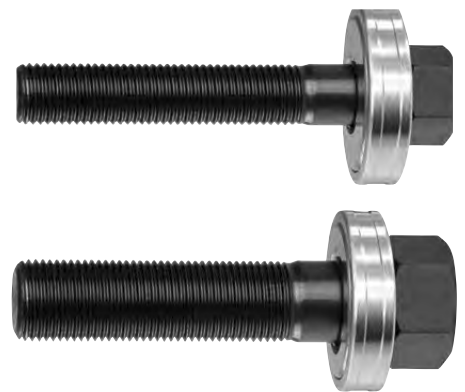

- 1 High-tensile bolts for the toughest operating conditions
- 2 Protrusion of ball bearing outside protective ring ensures perfect force transmission to wrench or punching tool
- 3 Ballbearings encapsulated in aluminium rings. Extremely long-life and perfectly protected against soiling
- 4 UNF fine thread

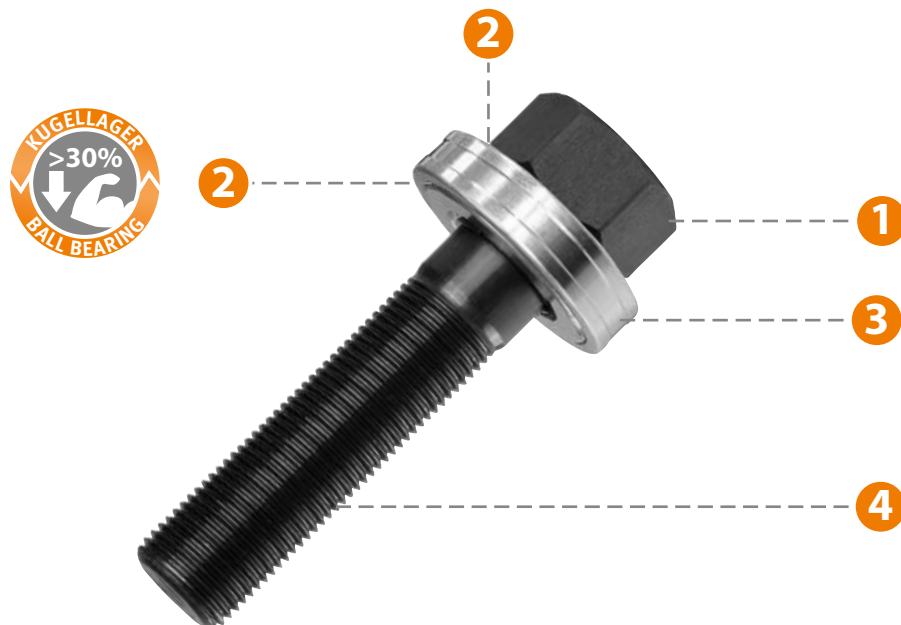

ACCESSORY PARTS – FOR HYDRAULIC PUMPS

		Prod.-No.
Hydraulic hose for Fußpumpe	2.80 m	02122
Hydraulic hose for LHP 700	2.00 m	02112
Hydraulic hose for DSP 120	2.50 m	02026
Hydraulic hose for AHP S	2.00 m	02116
Hydraulic hose for AHP M1 (03855)	2.00 m	03200-108M
Hydraulic hose for AHP M1 (03857) with control cable	2.00 m	03856
Hydraulic hose for AHP M1 (03857) without control cable	3.00 m	03858



Prod.-No. 02112

HYDRAULIC CYLINDERS AND ACCESSORIES

	Prod.-No.
Hydraulic cylinder SKP-1 with quick coupling (up to 11 t), weight 2.5 kg	02012
Hydraulic cylinder SKP-1 Mini with quick coupling (up to 7 t), weight 0.86 kg	02013
Spacer sleeve set 3-part	02004
Spacer sleeve set 5-part	02014
Pre-drill Ø 10.0 mm	08036
Pre-drill Ø 11.0 mm	08023
Pre-drill Ø 11.5 mm	08035
Pre-drill SVB with 5 drill Ø 8.5/11.5/12.5/16.5/21.0 mm	08016



Prod.-No. 02013



Prod.-No. 02014



Prod.-No. 08023



Prod.-No. 08016



Prod.-No. 02012

QUICK-CONNECT COUPLINGS – FOR ALFRA HYDRAULIC EQUIPMENT

- Non-drip coupling and decoupling
- Easy-to-use operability
- Dust protection cap

	Prod.-No.
Connection coupling with internal thread R 1/4" (for fitting to hose end)	01452
Connection coupling with internal thread R 3/8" (for fitting to hose end)	014523/8NPT
Connection nipple with internal thread R 1/4" (for fitting to cylinder)	01453
Adapter R 1/4" external thread	01454



Prod.-No. 01453

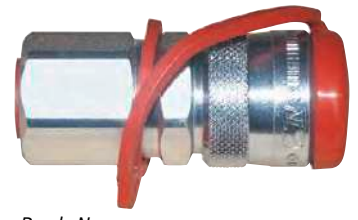

Prod.-No. 01452

ALFRA – SPECIAL METAL LUBRICATING PASTE

Application areas:

- Prevents seizing up, wear, cold-welding, solidifying and fretting corrosion on threads of screws, nuts, bolts, tube threads and fittings.
- ALFRA special metal lubricating paste is also particularly suitable for the lubrication of cutting points on punching tools and high-loading bearings and sliding surfaces.
- Release-active and silicone-free.
- Contents: 120 g

	Prod.-No.
ALFRA special metal lubricating paste	33005

Completely recommended for the use of hole punchers using wrenches.



Prod.-No. 33005

ALFRA – NOTCHING PLIERS

- Punchers notched grooves in sheet steel up to 2.0 mm thick simply and quickly (S235)
- Saves time-consuming filing of grooves for non-twist securing of pushbuttons, switches and instruments
- Notched grooves possible in sizes of 3.2 mm and 4.8 mm
- Easy punching due to large lever arm
- Plastic-coated handle
- Weight 1.3 kg

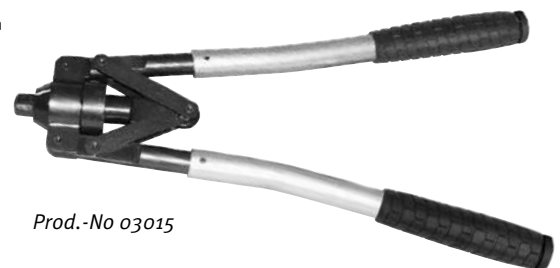
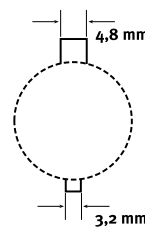

Prod.-No 03015

The notched groove puncher is introduced to the pre-punched opening, aligned to the crosshair markings and then the notched groove tongs are actuated. Your clean groove is finished!

	Prod.-No.
ALFRA notching pliers	03015



ALFRA CUTTING DEVICES

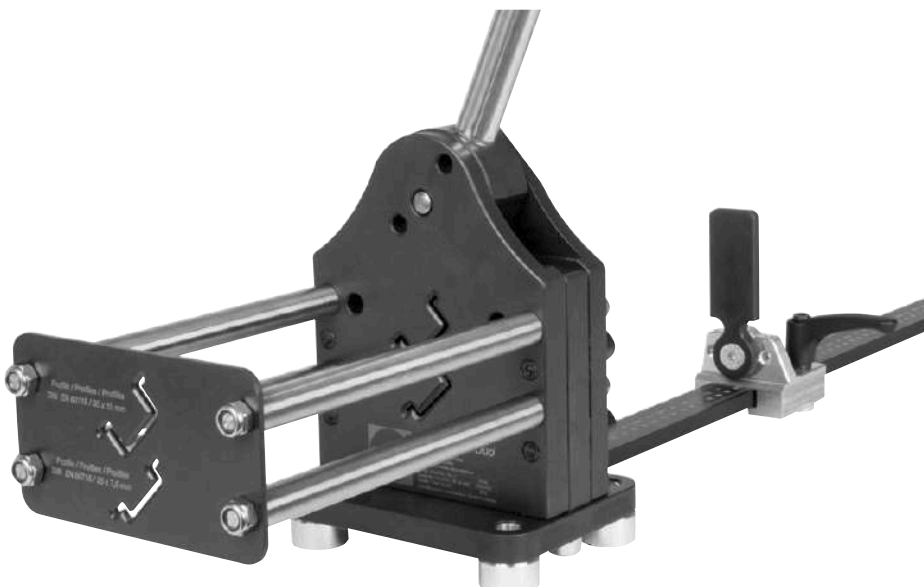
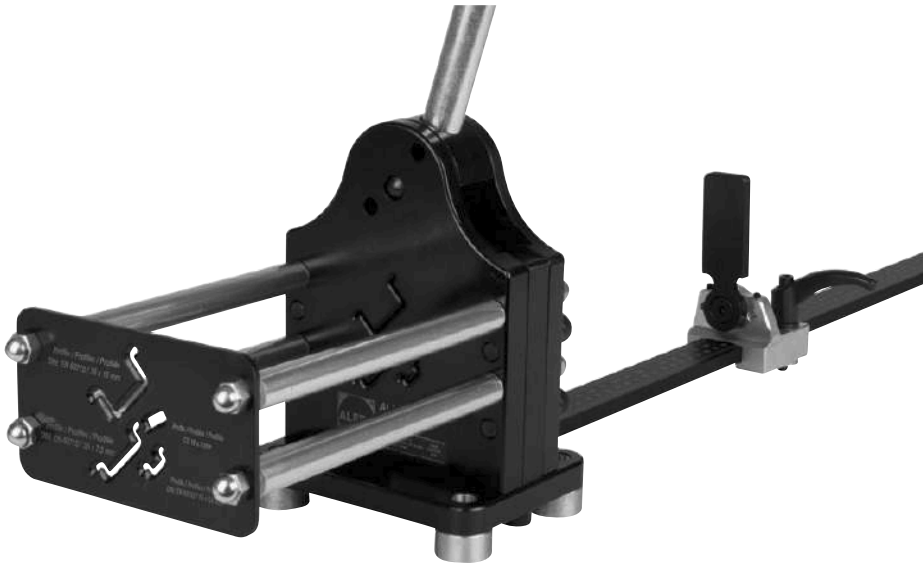
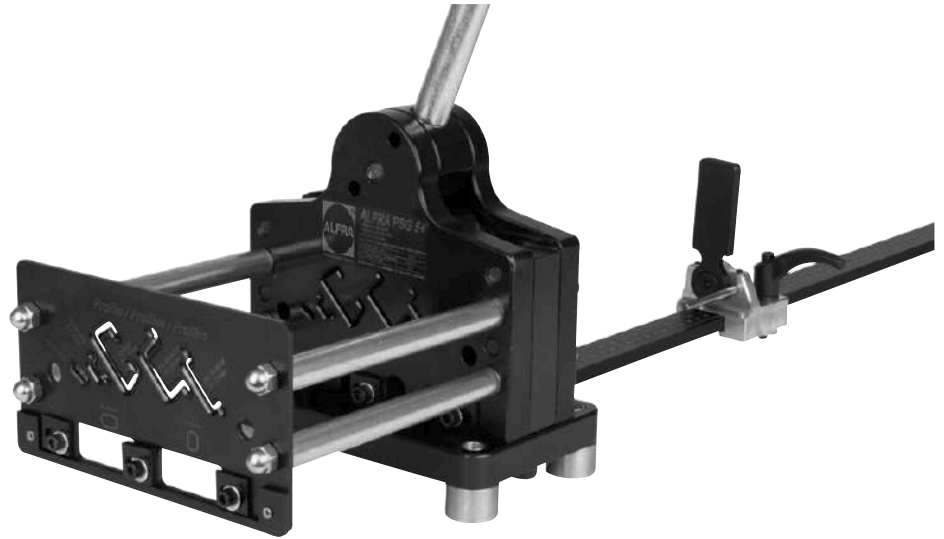

FOR MOUNTING RAILS

- **Handle: reinforced – soft touch**
- **Limit stop with mm/inch laser-engraved**
- **Burr-free, precise 90° cuts**
- **Lowest-possible cutting play**

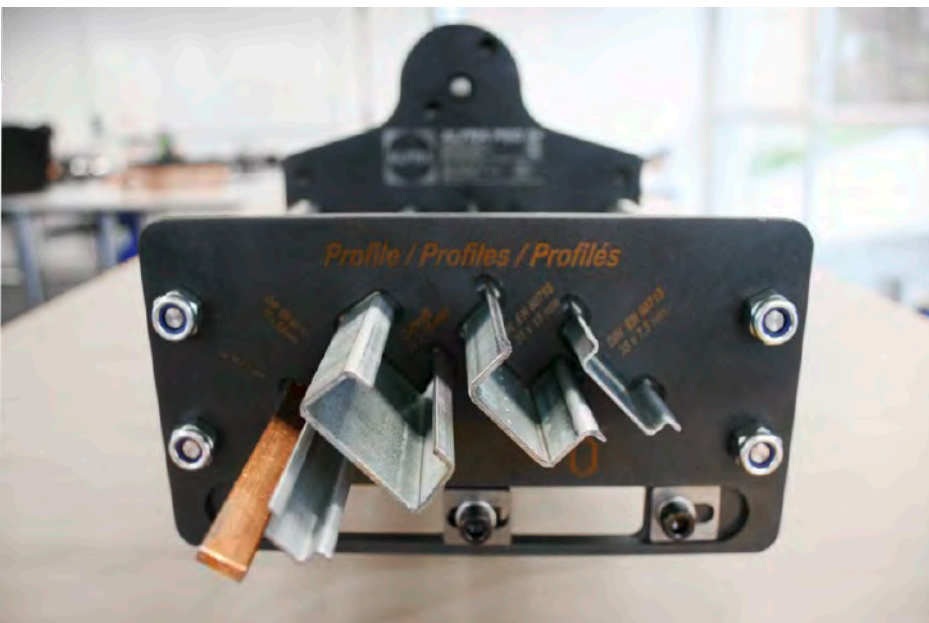

ALFRA PROFILE RAIL CUTTING DEVICE® – PSG DUO®



1

- 1 Handle: reinforced – soft touch
- 2 Limit stop with mm/inch laser-engraved
- 3 2 separate profiles for burr-free precise 90° cuts - stable profile guiding
- 4 Profile throughput is optimised for lowest-possible cutting play

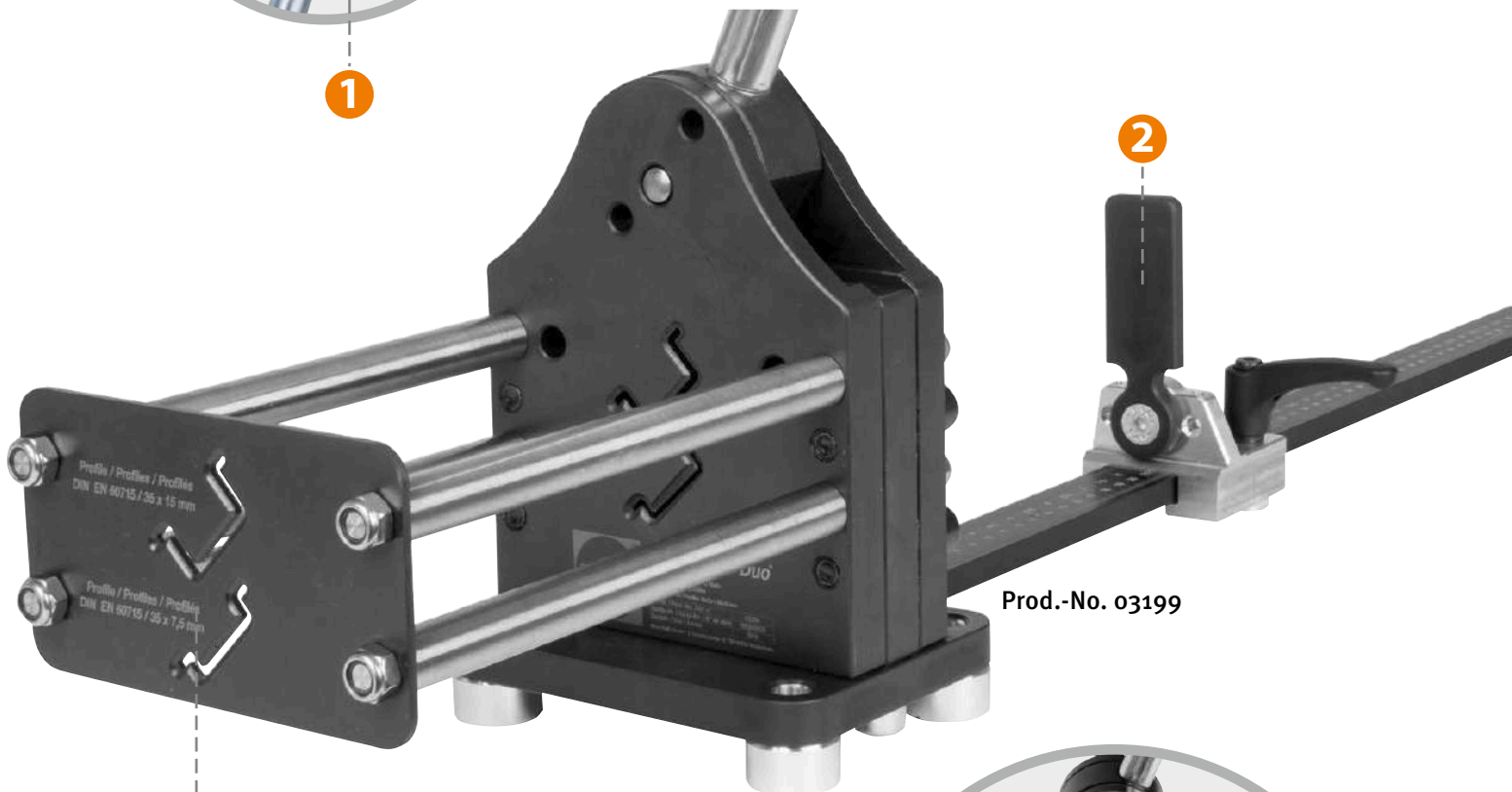

2

Prod.-No. 03199

3



4

ALFRA PROFILE RAIL CUTTING DEVICE® – PSG DUO®

For common mounting rails with hand lever operation

Cuts both profile rails TS 35/7.5 + 35/15 mm precisely and without effort

- With guide support for 90°-angle precise cutting
- With reinforced cam located directly above the shear plate
- Lower force application due to improved force transmission
- Maintenance-free
- Cutting to length without waste
- Shear plate re-grindable
- Anodised, laser-engraved oblong limit stop 1000 mm with guidance fixture for precise angled cutting to length with millimetre and inch scaling.
- Easy to install on the workbench
- Scale divisions metric and inches

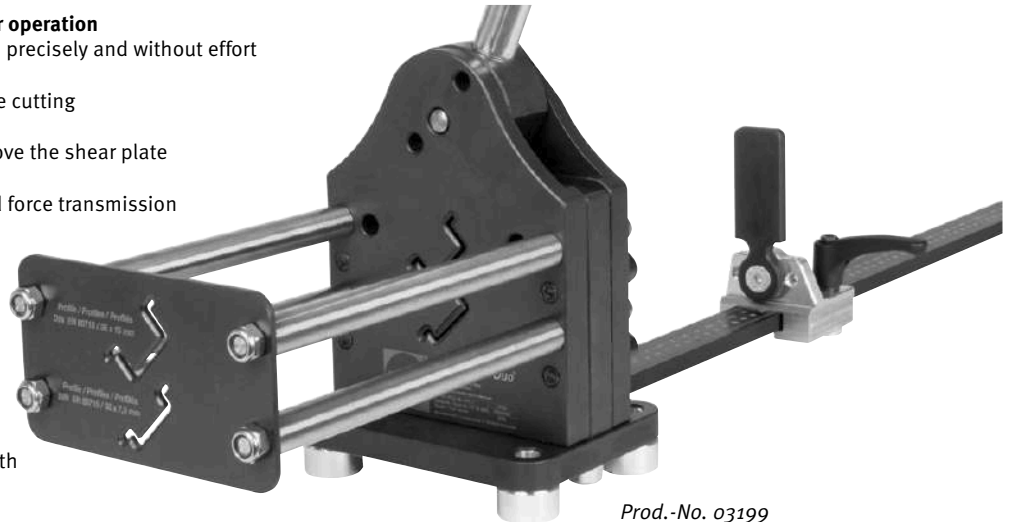

Prod.-No. 03199

Prod.-No.

ALFRA profile rail cutting device® – PSG Duo®

03199

Profile rails

Mounting rail
35 mm/7.5
as per EN 60715

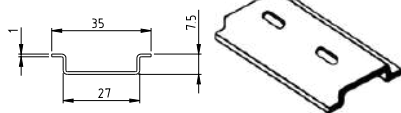

Mounting rail
35 mm/15
as per EN 60715

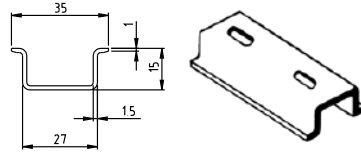

**Custom-made products for
special profiles on request!**



ALFRA PROFILE RAIL CUTTING DEVICE® – PSG 4®



1

- 1 Handle: reinforced - soft touch
- 2 Limit stop with mm/inch laser-engraved
- 3 Profile throughput is optimised for lowest-possible cutting play

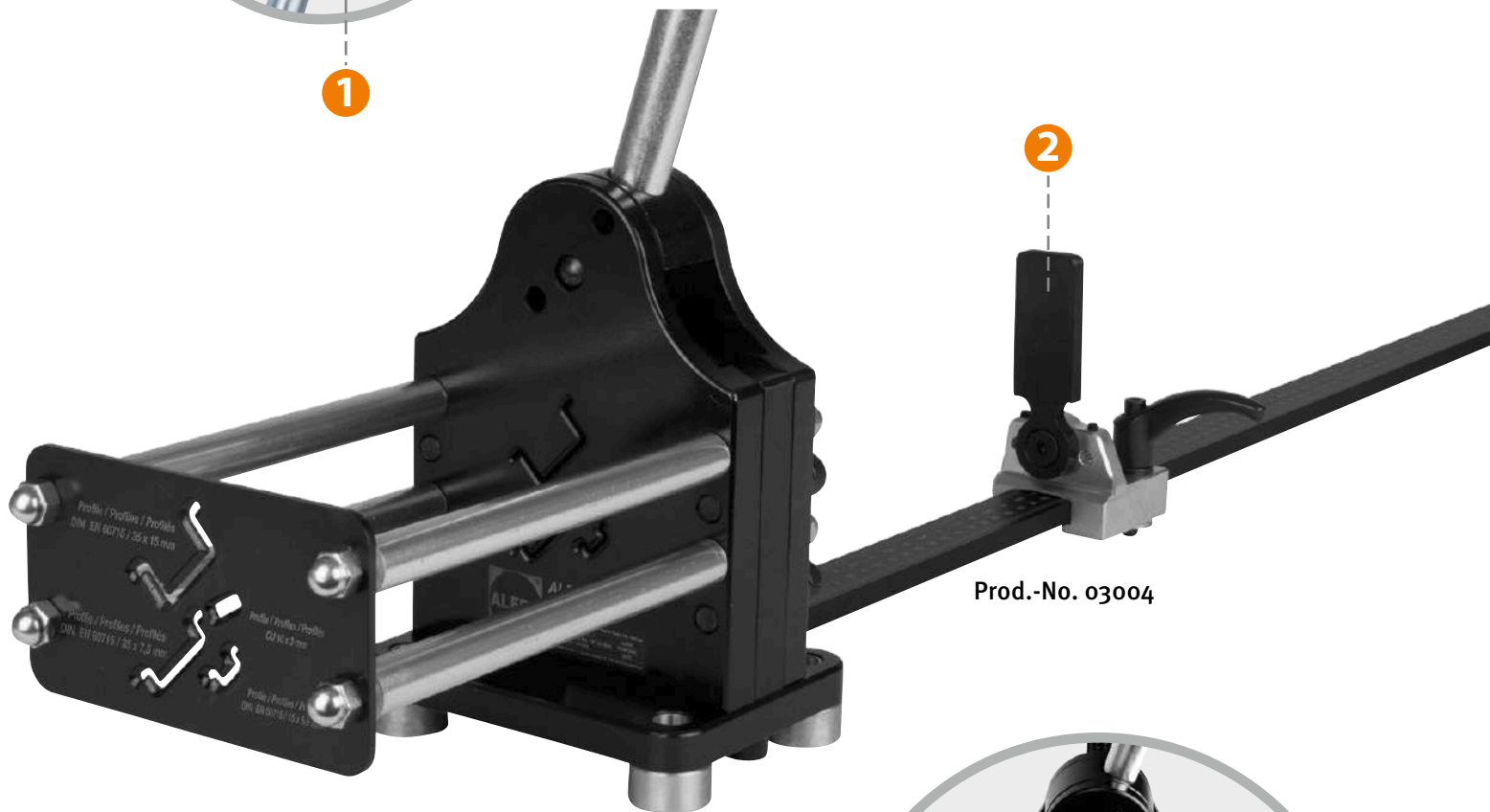

2

Prod.-No. 03004



3

ALFRA PROFILE RAIL CUTTING DEVICE® – PSG 4®

For hand-operated mounting rails

Cuts profile and ground rails precisely and without effort.
Standard version for TS 35/7.5 - 35/15 - 15/5.5 - Cu 10.0 x 3.0 mm

- With reinforced cam located directly above the shear plate
- Lower force application due to improved force transmission
- Burr-free cutting to length without waste
- Maintenance-free
- Anodised, laser-engraved length limit stop 1,000 mm with guiding device for precise angled cutting to length, with millimetre and inch scaling
- Shear plate re-grindable
- Guidance fixture for 90° angle-precise cutting
- Easy to install on the workbench
- Custom-made products are also possible (please send us a sample rail of about 1,000 mm length)

ALFRA profile rail cutting device® – PSG 4®

Prod.-No.
03004

Standard version

Mounting rail
35 mm/7.5
as per EN 60715

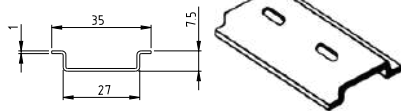

Mounting rail
35 mm/15
as per EN 60715

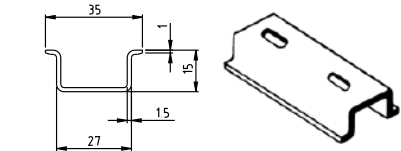

Mounting rail
15 mm/5.5
as per EN 60715

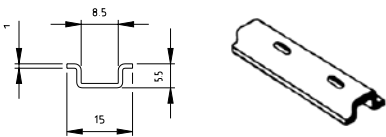

Copper ground rails
10 mm x 3 mm

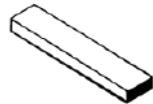

Guidance fixture
for 90° angle-precise cutting



Prod.-No. 03004

ALFRA PROFILE RAIL CUTTING DEVICE[®] – PSG 5+[®]



1

- 1 Handle: reinforced – soft touch
- 2 Limit stop with mm/inch laser-engraved compatible with PSG series
- 3 Profile throughput is optimised for lowest-possible cutting play

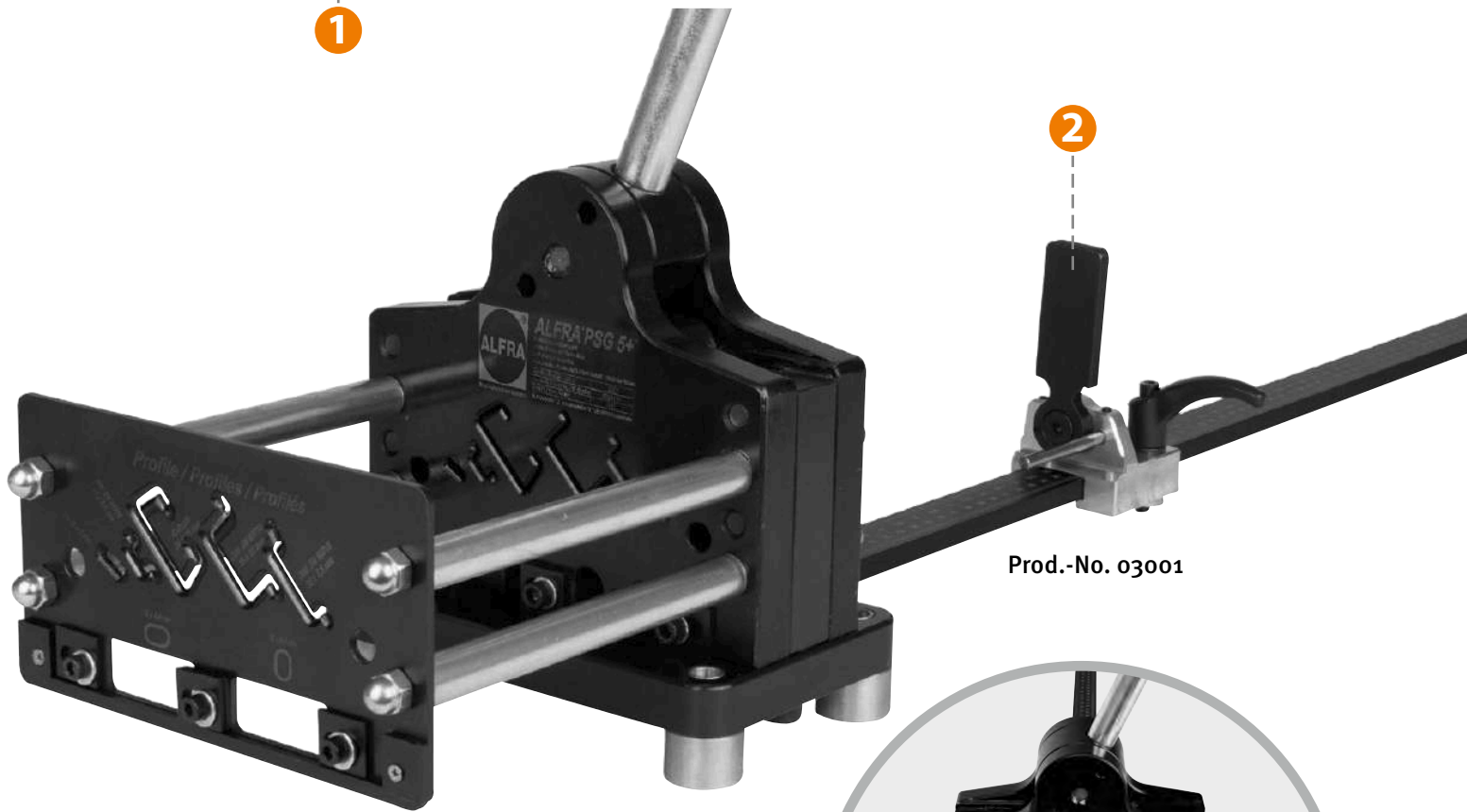

2



3

ALFRA PROFILE RAIL CUTTING DEVICE® – PSG 5+®

For mounting rails, for hand lever operation for **cutting to length and hole punching oblongly and transversely** on the depicted mounting rails.

- With reinforced cam located directly above the shear plate
- Lower force application due to improved force transmission
- Burr-free cutting to length without waste
- Maintenance-free
- Anodised, laser-engraved length limit stop 1,000 mm with guiding device for precise angled cutting to length, with millimetre and inch scaling
- Shear plate can be re-ground, puncher replaceable
- Custom-made products are also possible (please send us a sample rail of about 1,000 mm length)

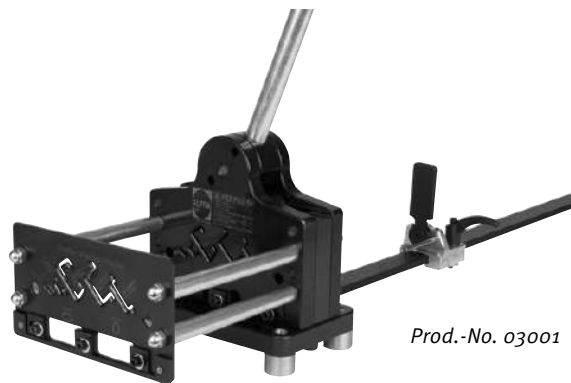

Prod.-No. 03001

Tool for fixing holes (oblong and transverse) integrated.
Guidance fixture for 90° angle-precise cutting

Scope of delivery standard version	Prod.-No.
with transverse and oblong hole puncher 12 x 6.4 mm, 1000 mm length limit stop and guidance fixture incl. C-profile 3415	03001
with transverse and oblong hole puncher 12 x 6.4 mm, 1000 mm length limit stop and guidance fixture incl. G-profile as per EN 60715	03001G
as 03001, however with round hole puncher Ø 5.5 mm	03002-5.5
as 03001, however with round hole puncher Ø 6.0 mm	03002-6.0
as 03001, however with hydraulic cylinder	03003

Standard version

Mounting rail
35 mm/7,5
as per EN 60715

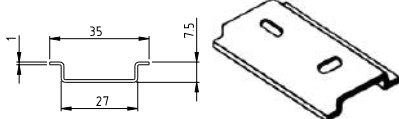

Mounting rail
35 mm/15
as per EN 60715

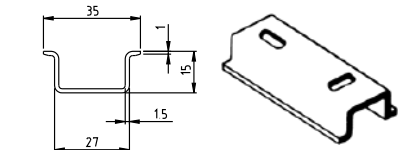

Mounting rail
15 mm/5,5
as per EN 60715

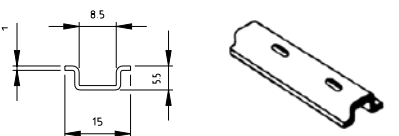

C-profile 3415
(included in Prod.-No. 03001)
as per EN 60715

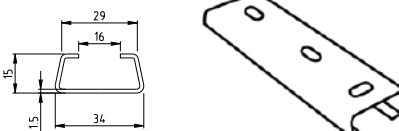

G-profile
(included in Prod.-No. 03001G)
as per EN 60715

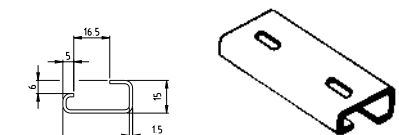

Copper ground rails
10 mm x 3 mm



Spare parts for universal cutting and punching device

Spare parts for universal cutting and punching device	Prod.-No.
Spare puncher + die 12 x 6.4 mm f. oblong hole	03005
Spare puncher + die 12 x 6.4 mm f. transverse hole	03006
Spare puncher + die 5.5 mm f. round hole	03007
Spare puncher + 6.0 mm f. round hole	03008
Special versions for mounting rails or flat rails, also in copper or aluminium or plastic on request	03011



Prod.-No. 03003

We recommend our pump type AHP S (Prod.-No. 03854) as a drive

VKS 125 031903
Verdrängungsartabschneidergerät
Wiring duct cutting tool

ALFRA
ALFRA-Systeme

max: 125 mm | 4.9"
max: 20 mm | 1.1"
max: 2,5 mm | 0.1"

PVC und halogenfreie Kanäle |
PVC and halogen-free cable ducts

SN: 2033
BJ: 2019

Wichtig:
2. Einsatzschritte 10
www.alfra.de
119826310



▶ VIDEO

“The fact that the VKS 125 wiring duct cutter was developed from practical experience is noticeable when working... Anyone who relies on frequently cutting wiring ducts to size in production will quickly learn to appreciate the quiet, precise and safe device.”

Martin Mertens
Technical Editor
Motor & Maschine 1/2019



☰ PDF



ALFRA CABLE DUCT CUTTING DEVICE – VKS 125

ALFRA cable duct cutting device – VKS 125

Cuts cable ducting and covers up to 125 mm wide in seconds precisely and without effort. Fixing tabs for easy fitting to the Workbench are attached to the device and to the oblong limit stop.

The VKS 125 is fitted with a sprung cutter protector which covers the cutter when it is not being used.

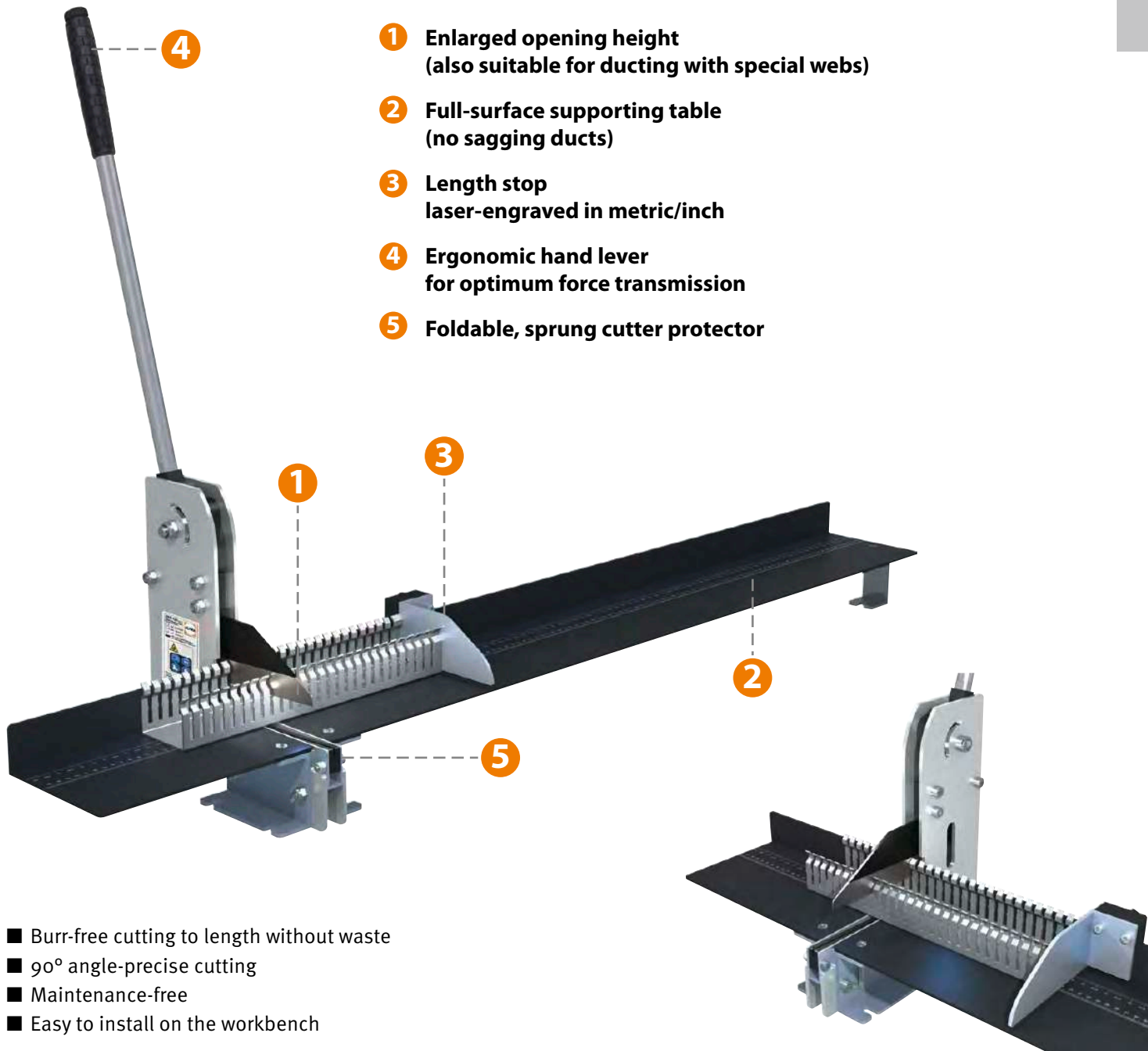

- 1 Enlarged opening height
(also suitable for ducting with special webs)
- 2 Full-surface supporting table
(no sagging ducts)
- 3 Length stop
laser-engraved in metric/inch
- 4 Ergonomic hand lever
for optimum force transmission
- 5 Foldable, sprung cutter protector

- Burr-free cutting to length without waste
- 90° angle-precise cutting
- Maintenance-free
- Easy to install on the workbench

“...no more plastic swarf and no more deburring!”



ALFRA VKS 125
Cutter for VKS 125

Prod.-No.
031920
03192

ALFRA ASSEMBLY TABLE



Simply put together your desired assembly table with its accessories on our website and then request a quotation by clicking:
www.schaltschrank123.de/en

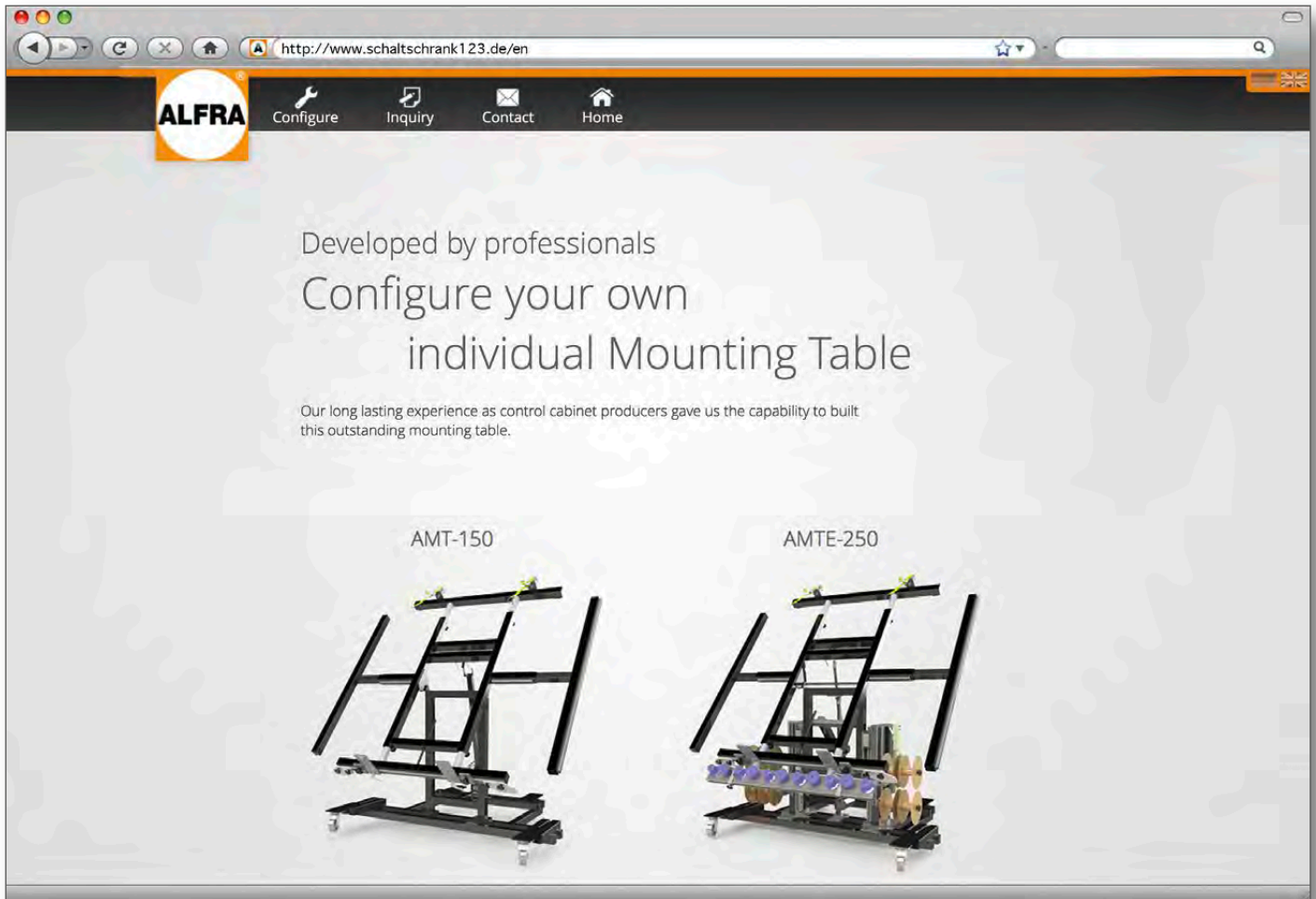

ALFRA ASSEMBLY TABLE AMT 150



AMT 150

Prod.-No.	03100
Simple, variable fixing of mounting panels using quick-action clamp.	✓
Intelligent release system enables unrestricted processing of the entire mounting panel	✓
Infinitely variable adjustment from vertical to horizontal	using handcrank or battery drill
Infinitely variable height adjustment	via angle of inclination
Electric motor	-
Battery-operated	-
Adjustable angle of inclination	0 - 80°
Working height	fixed: 100 cm
4 guide rollers with total fixing	✓
Max. size mounting panels W x H	1,100 x 1,900 mm
Max. useful load	150 kg
Space requirement	1,400 x 1,200 mm
Weight	83 kg
Scope of delivery	Assembly table AMT 150 2 x clamping unit with bolt 2 x clamping unit with quick lock Screw adapter for operating with battery drill

OPTIONS FOR ALL AMTs

 <p>EXTENSION SET Table width extension for horizontal support of mounting panels Prod.-No. 03100-001</p>	 <p>CLAMPING UNIT WITH QUICK LOCK Prod.-No. 03100-003</p>	 <p>CABLE GUIDANCE Prod.-No. 031001-003</p>
	 <p>CLAMPING UNIT WITH BOLT Prod.-No. 03100-002</p>	

OPTION FOR AMT 150

SCREW ADAPTER AMT 150
for operation with battery drill
Prod.-No. 03100-004

ALFRA ELECTRIC ASSEMBLY TABLE AMTE 250



AMTE 250

031001



using battery-operated electric motors

using battery-operated electric motors



0 - 80°

variable: 80 - 110 cm



1,100 x 1,900 mm

300 kg

1,400 x 1,200 mm

140 kg

Electric assembly table AMTE 250
 2 x clamping unit with bolt
 2 x clamping unit with quick lock
 external charging station for the battery, with charging plug 220 V

OPTIONS FOR ALL AMTs

OPTIONS FOR AMTE 250



CONTROL CABINET SET
 Prod.-No. 03100-005



CABLE ROLL HOLDER
 Prod.-No. 031001-002



ROLLER CONVEYOR
 for sideways insertion of the mounting panel
 into the control cabinet
 Prod.-No. 031001-004

OPTIONS FOR AMTE 250

SPARE BATTERY
 Prod.-No. 031001-001

CHARGING PLUG
 for 110 V 60 Hz
 Prod.-No. 031001-0011

ALFRA BUSBAR MACHINING



▶ VIDEO

ALFRA BUSBAR BENDING AND HOLE PUNCHING DEVICE

Busbars at 120 x 12 mm can easily be bent using a universal working cylinder, and holes of Ø 6.6 up to 21.5 mm including oblong holes can be punched through the simple insertion of hole punchers.



Bending busbars

Turn switch to “bend”

To bend busbars, the bending die is inserted in the hydraulic piston and the electric angle measurer is placed in the round guidance crew on the counter block. The contact cable is connected to the electric motor. The required angle is fixed on the angle scale using an adjusting screw.

Since copper springs back, we recommend making a setting 1° - 3° above the required angle depending on the material thickness.

You should check the first bending angle. This bending angle can be reproduced as often as required since the bending process is automatically interrupted on achieving the angle by the electrical contact switch.

Technical data Bending

Bending Cu max:	120 x 12 mm
Bending up to:	more than 90°
smallest leg length:	50 mm
smallest U-bend:	100 mm
smallest Z-bend:	72 mm (depending on material thickness)

The values stated are based on copper rails 120 x 10 mm



Punching busbars

Switch setting to “punch”

The puncher with the neoprene scraper and the matching die are placed in the locating hole.

The puncher is fixed sideways using a grub screw. Depending on the busbar width and the required hole arrangement, the processing block can be infinitely variably raised or lowered hydraulically using the handwheel. A counter attached to the handwheel shows the height of the hole centre in millimetres.

We recommend centre-punching the busbar and then aligning the puncher centring point above the centre puncher to guarantee a precise hole location.

The neoprene scraper and a fitted electronic sensor ensure automatic puncher retraction.

Technical data Punching

Punching Cu:	6.6 - 21.5 mm also oblong hole up to max. L = 21 mm
Material thickness Cu max:	12 mm
Material width up to:	110 mm central
External dimensions L x W x H:	700 x 410 x 410 mm
Weight:	60 kg

ALFRA BS 120 CU-BUSBAR BENDING AND HOLE PUNCHING DEVICE

Two functions, one device: With the BS 120 CU from Alfra, control cabinet builders can bend and punch copper busbars in just a few steps. In bending mode, the bending-die simply has to be inserted into the hydraulic piston. The required bending angle is to be set by using the adjusting screw.

In punching mode, the BS 120 CU punches holes with a diameter between 6.6 mm and 21.5 mm or oblong holes up to max. 21.0 x 18.0 mm, depending on the used punch. The universal working cylinder processes busbars up to 120 mm x 12 mm.

In addition, the BS 120 CU scores with various safety features.

Included accessories:

- Electric angle reader
- Bending die
- Length stop

	Prod.-No.
BS 120 CU-busbar bending and hole punching device	03200SET.NG
Electrical angle measurer R10	03201.NG
Bending die R10	03202.L
Length limit stop	03203
Bending die with movable jaws (120 x 10 mm Cu)	03228
Stage bending tool with 2 pairs of pressure plates for 5 and 10 mm stages (max. range: 100 x 5 mm / 60 x 10 mm Cu)	03246

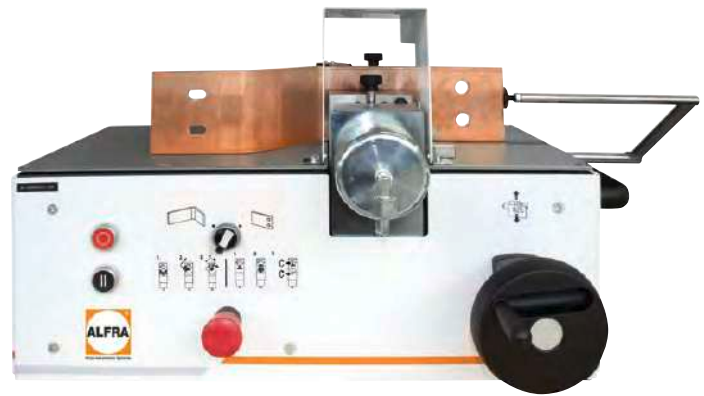

Prod.-No. 03200SET.NG



Prod.-No. 03201.NG



Prod.-No. 03202.L



Prod.-No. 03228

Electro-hydraulic pump AHP M1

Technical data:

Max. pressure:	700 bar
Max. flow rate:	1.1 l/min
Oil type:	HLP 46
Filling volume:	3.2 l
Working volume:	2.2 l
Weight:	29 kg
Operating voltage:	230 V / 50 Hz
Power:	1.3 kW
Current consumption:	5.7 A
Motor speed:	2,860 rpm

	Prod.-No.
Electro-hydraulic pump AHP M1 incl. hydraulic hose 2.00 m	03857
Foot switch with safety function (accessories necessary for operation)	03862.NG



Prod.-No. 03857



Prod.-No. 03862.NG Foot switch

ALFRA BS 120 CU-BUSBAR BENDING AND HOLE PUNCHING DEVICE

Bend, punch, ready, go!

With the Alfra BS 120 CU busbar bending and punching device in the set variant, enclosure builders can get started immediately, because the bending-die, electric angle reader, foot switch and hydraulic pump are included in the scope of delivery (punching tools are available as an option depending on the required dimensions).

This means: Precise bending and punching is done by simple conversion in just a few steps. Even in the set version, you benefit from improvements to protect the machine.

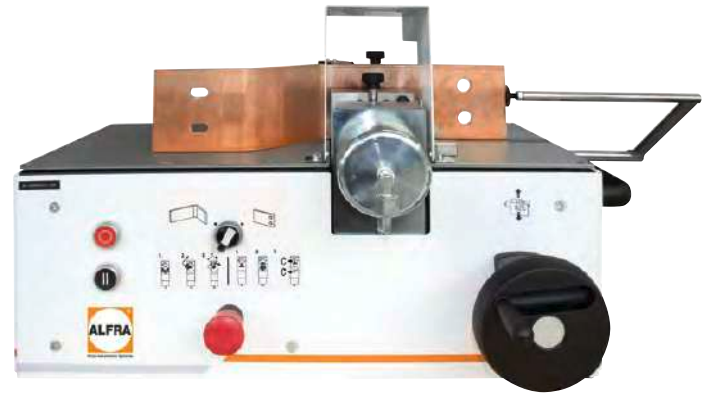

ALFRA BS 120-Set

Prod.-No.
03912

- Prod.-No. 03200SET.NG
ALFRA BS 120 CU-busbar bending and hole punching device
- Prod.-No. 03857
Electro-hydraulic pump **AHP M1**
- Prod.-No. 03862.NG
Foot switch with safety function

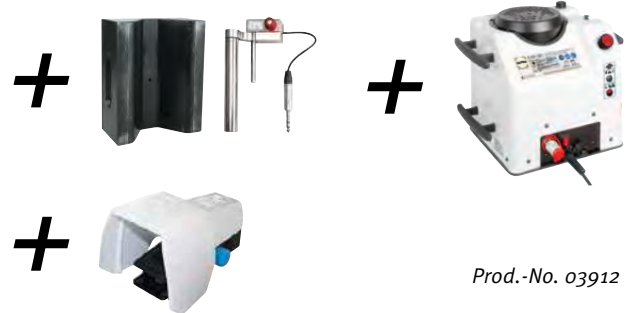

Prod.-No. 03912

Accessories

Punches and dies

Punch Ø in mm	Metric Screw connection	Max. Material thickness in mm	Prod.-No.
6.6	6.0	5.0	03204
9.0	8.0	6.0	03205
9.5	8.0	6.0	03206
11.0	10.0	12.0	03207
11.5	10.0	12.0	03208
13.5	12.0	12.0	03209
14.0	12.0	12.0	03210
17.5	16.0	12.0	03211
18.0	16.0	12.0	03212
21.0	20.0	12.0	03213
21.5	20.0	12.0	03214



Round punches and dies

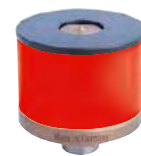

oblong hole punches and dies

Die Ø Max. in mm	Material thickness in mm	Prod.-No.
6.6	5.0	03230
9.0	6.0	03231
9.5	6.0	03232
11.0	12.0	03233
11.5	12.0	03234
13.5	12.0	03235
14.0	12.0	03236
17.5	12.0	03237
18.0	12.0	03238
21.0	12.0	03239
21.5	12.0	03240

Punches and dies for oblong holes up to max. L x W = 21 x 18 mm
on request

Prod.-No.
03241

ALFRA BUSBAR CUTTING DEVICE – S 125

For clean, burr-free cutting of copper busbars
max. 125 x 12 mm.

- Ideal supplementary device for busbar bending and hole punching device.
- Cutting time with electro-hydraulic pump depending on rail width 5 - 15 sec.
- Hold-down device and guidance fixture for central, precise cutting.
- Top cutter replaceable and resharpenable.
- With laser marking on the cut edge
- Hand protection cover (plexiglass cover)
With access protection on the right and left side of the device (plexiglass cover). This safely shields the cutting area of the knife and prevents the user from accidentally interfering with the area.
- Emergency stop switch

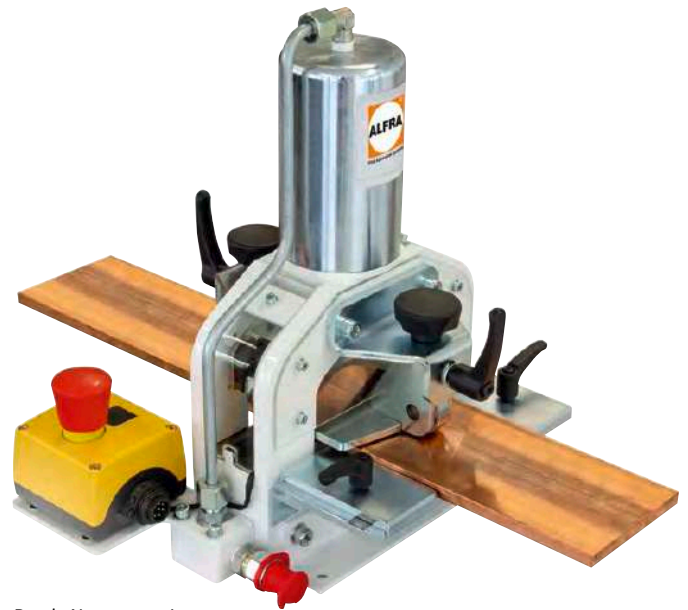

Prod.-No. 03250.L

Prod.-No.

ALFRA busbar cutting device – S 125	03250.L
Replacement top cutter	03251
Electro-hydraulic pump AHP M1	03857
Foot switch with safety function (accessories necessary for operation)	03862.NG
Support roller (2 pieces)	03257



Prod.-No. 03257



(Picture shows options)

ALFRA BUSBAR BENDING AND HOLE PUNCHING DEVICE – BS 160

- The device consists of a base frame made of special aluminium and a hydraulic cylinder up to 600 bar
- Using bending dies R=11 mm and R=5 mm and height adjustment, all busbars of up to max. 160 mm width can be bent to various angles
- The angle measurement is engraved on the top section
- Changing over to bending and hole-punching is easy and simple

Technical data:

Bending

Bending Cu max.:	160 x 12 mm
Bending angle up to:	92°
smallest leg length:	50 mm internal dimension
smallest U-bend:	160 mm internal dimension
smallest Z-bend:	55 mm (material-dependent) internal dimension

Punching

Punching Cu max.:	Ø 6.6 - 21.5 mm also oblong hole up to max. L = 21 mm
Material thickness Cu max.:	12 mm
Material width up to:	160 mm central
Dimensions L x W x H:	390 x 150 x 330 mm
Weight:	20 kg

	Prod.-No.
ALFRA BS 160 with bending die R=11 mm for busbars 9-12 mm	03258

Recommended drive type

Foot pump only, with 2.8 m hydraulic hose	02121
Electro-hydraulic pump AHP M1	03857
Foot switch with safety function	03862.NG

Accessories

Bending punch R=5 mm for busbars 3-8 mm	03259
---	-------

Punches and dies

Punch Ø in mm	Metric Screw connection	Max. Material thickness in mm	Prod.-No.
6.6	6.0	5.0	03204
9.0	8.0	6.0	03205
9.5	8.0	6.0	03206
11.0	10.0	12.0	03207
11.5	10.0	12.0	03208
13.5	12.0	12.0	03209
14.0	12.0	12.0	03210
17.5	16.0	12.0	03211
18.0	16.0	12.0	03212
21.0	20.0	12.0	03213
21.5	20.0	12.0	03214

Die Ø Max. in mm	Material thickness in mm	Prod.-No.
6.6	5.0	03230
9.0	6.0	03231
9.5	6.0	03232
11.0	12.0	03233
11.5	12.0	03234
13.5	12.0	03235
14.0	12.0	03236
17.5	12.0	03237
18.0	12.0	03238
21.0	12.0	03239
21.5	12.0	03240

Punches and dies for oblong holes up to max. L x W = 21 x 18 mm	Prod.-No.
	03241

Bending busbars up to 160 x 12 mm

Punching busbars Ø 6.6 - 21.5 mm



CONTROL CABINET CONSTRUCTION WITH ALFRA PRESS



“A company with the goal of producing products close to the needs of control cabinet builders, must immerse deeply into their working world. The machines from the ALFRA PRESS series therefore have various details drafted for the requirements of the industry. One example: thanks to different die supports, users can also punch in areas, which are situated very close to edges. A laser pointer is indicating the centre of the tool.”

Published in “Schaltschrankbau” 7/2020



PDF



ALFRA PRESS – OVERVIEW



ALFRA PRESS AP 250

Page	64 - 67
Application	Control cabinet housing, Control cabinet doors, Mounting panels
Prod.-No.	03170
Overhang with limit stop in mm	250
Overall height in mm	820
Total weight in kg approx.	50
Space requirement in mm	1,000 x 1,000
Base	— (for workbench mounting)
Tool dimension in mm:	
Circular Ø	3.2 – 40.5
Square up to	28.0 x 28.0
Max. diagonals of	40.0
Max. material thickness in mm:	
Sheet steel S235 / stainless steel	2.5 / 2.0
Aluminium / plastic	4.0
Hydraulic system:	
Mode of action	single-action
Punching force F	46 kN at 600 bar
Punching stroke in mm	50
Operating voltage in V	-
Workpiece fold in mm	22

ALFRA PRESS – OVERVIEW



ALFRA PRESS AP 400



ALFRA PRESS AP 600

	68 - 71	72 - 75
	Control cabinet housing, Control cabinet doors, Mounting panels	Control cabinet doors, Mounting panels
	03195	03090
	400	600
	1,700	1,600
	220	360
	1,200 x 800	2,000 x 3,000
	✓ mobile base	✓ stationary base
	3.2 – 40.5	3.2 – 70.0
	28.0 x 28.0	68.0 x 68.0
	40.0	90.0
	2.5 / 2.0	3.0 / 2.0
	4.0	4.0
	single-action	double-action
	46 kN at 600 bar	60 kN at 165 bar
	50	66
	-	400
	22	30

PUNCHING WITHOUT PRE-DRILLING

Apress **250**

Overhang 250 mm



ALFRA PRESS AP 250 - STATIONARY PUNCHING MACHINE

For rapid punching-out of circular, square, rectangular or special forms without pre-drilling in control cabinet doors, terminal boxes, cable ducts, housings, cable management panels etc. right up to margins. Simple tool change carried out in seconds.

Description:

- Stationary fitted on the workbench
- Rapid tool change helps in problem areas with a wide range of break-through types
- A range of die mountings is available, even for punching very close to margins
- Rows of punch-outs are no problem thanks to attachable folding stops
- Use a laser pointer - no scribing, no centre punching, a simple crosshair with the pin is sufficient
- Operation using a manual foot pump is sufficient as a "starter solution" – this makes "punching without pre-drilling" possible at low cost

Technical data:

Overhang with limit stop:	250 mm
Overhang without limit stop:	265 mm
Punching stroke:	50 mm
Punching force F:	46 kN at 600 bar
Hydraulic connection:	R 1/4"
Weight:	50 kg
Space requirement with base approx.:	1,000 mm x 1,000 mm

Punching capacity:

Circular:	Ø 3.2 - 40.5 mm
Square:	28.0 x 28.0 mm
Rectangle:	22.0 x 30.0 mm
Special forms up to a max. diagonal of:	40.0 mm

Material thicknesses (max):

Sheet steel (S235):	2.5 mm
Stainless steel (F = 600 N/mm ²):	2.0 mm
Aluminium (F = 22 N/mm ²):	4.0 mm
Punchable plastics:	4.0 mm

ALFRA PRESS AP 250

Prod.-No.
03170

Note:

- All circular tools for ALFRA PRESS punchers AP 250 - AP 600 are made of special tool steel and have a special cutting geometry developed by ALFRA

Special tools on request!

Technical features when punching close to margins with die holder Type I

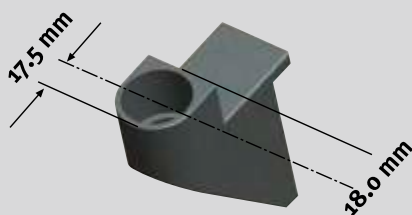

Smallest-possible axial dimension (border spacing) when using die holder Type I

Prod.-No. 03174



Laser pointer for optical display of tool centre and power bank



Tool drawer, pivoting



Length and depth limit stop with foldable add-on stops



Pivoting support arms, height adjustable, each with 2 rubber supports



Prod.-No. 03854

We recommend our electro-hydraulic pump AHP S (Prod.-No. 03854) as a drive unit



Prod.-No. 02121

Alternatively, the Alfra stationary hole punchers can be operated with our foot pump
Prod.-No. 02121

PUNCHING WITHOUT PRE-DRILLING

APress 250

Overhang 250 mm

Stationary hole puncher – AP 250

Type	Designation	Prod.-No.
Machine	Punching machine ALFRA PRESS 250 with hydraulic cylinder and quick coupling, cylinder piston with non-twist device for insertion of all punch sockets, integrated Laser pointer and power bank, combined length and depth limit stops with 2 adjustable limit stops per axis. The limit stops in the X direction are foldable and are suitable as an add-on limit stop for rows of punch-outs. Pivoting support arms (pairs) height adjustable, each with 2 rubber supports.	03170
Pump	Electro-hydraulic pump AHP S	03854
	Foot switch 2-pedal for electro-hydraulic pump AHP S	03866
Punch socket	with scraper and centring pin Ø 3.2 - 30.5 mm with mounting shaft for AP 250 - 400	03171
	with scraper and centring pin for round puncher Ø 30.6 - 40.5 mm with 19 mm Female thread for AP 250 - 400	03172
Die holder	Type I Dies Ø 3.2 - 22.5 mm for punching right up to margins for AP 250 - 400	03174
	Type II Dies Ø 3.2 - 30.5 mm and moulding tool up to 21 x 21 mm (30.5 mm max. diagonals) for AP 250 - 400	03175
	Type IV Dies Ø 30.6 - 40.5 mm and moulding tool up to 28 x 28 mm (40.0 mm max. diagonals) AP 250 - 400	03176

Square and rectangular hole punches – AP 250

suitable for steel and stainless steel, with mounting shaft and centring point, including die

Type	Designation	Prod.-No.	AP 250	AP 400	AP 500	AP 600
Square holes	21.0 x 21.0 mm for AP 250 - 400	03087	●	●		
	25.4 x 25.4 mm for AP 250 - 400	03088	●	●		
Rectangular holes	22.0 x 30.0 mm for AP 250 - 400	03089	●	●		
Special holes	Ø 22.5 mm with 4 lugs for AP 250 - 400	03086	●	●		
Spare neoprene scraper	for punch socket (03171) Ø 3.2 - 30.5 mm	03185	●	●		
	for punch socket (03172) Ø 30.6 - 40.5 mm	03186	●	●		

ALFRA PRESS AP 250 - STATIONARY PUNCHING MACHINE

Circular punches and dies – AP 250 suitable for steel and stainless steel										
Type	Mounting holder	Ø in mm	Size Metric	Size PG	Prod.-No.	AP 250	AP 400	AP 500	AP600	AP 800
Punch Ø 3.2 - 30.5 mm		3.2			03131	●	●	●	●	●
		4.5			03132	●	●	●	●	●
		5.4			03133	●	●	●	●	●
		6.5			03134	●	●	●	●	●
		8.5	M8		03135	●	●	●	●	●
		10.5	M10		03136	●	●	●	●	●
		12.7	M12	PG7	03137	●	●	●	●	●
		15.2		PG9	03138	●	●	●	●	●
		16.2	M16		03139	●	●	●	●	●
		18.6		PG11	03140	●	●	●	●	●
		20.4	M20	PG13	03141	●	●	●	●	●
		22.5		PG16	03142	●	●	●	●	●
		25.4	M25		03143	●	●	●	●	●
		28.3		PG21	03144	●	●	●	●	●
Punch Ø 32.5 - 40.5 mm		30.5			03145	●	●	●	●	●
		32.5	M32		03146	●	●	●	●	●
		37.0		PG29	03158	●	●	●	●	●
Die Ø 3.2 - 22.5 mm	TYPE I	40.5	M40		03147	●	●	●	●	●
		3.2			03500	●	●			
		4.5			03501	●	●			
		5.4			03502	●	●			
		6.5			03503	●	●			
		8.5	M8		03504	●	●			
		10.5	M10		03505	●	●			
		12.7	M12	PG7	03506	●	●			
		15.2		PG9	03507	●	●			
		16.2	M16		03508	●	●			
		18.6		PG11	03509	●	●			
		20.4	M20	PG13	03510	●	●			
		22.5		PG16	03511	●	●			
		Die Ø 3.2 - 30.5 mm	TYPE II	3.2			03063	●	●	●
4.5					03066	●	●	●	●	●
5.4					03068	●	●	●	●	●
6.5					03074	●	●	●	●	●
8.5	M8				03076	●	●	●	●	●
10.5	M10				03079	●	●	●	●	●
12.7	M12			PG7	03022	●	●	●	●	●
15.2				PG9	03023	●	●	●	●	●
16.2	M16				03084	●	●	●	●	●
18.6				PG11	03024	●	●	●	●	●
20.4	M20			PG13	03025	●	●	●	●	●
22.5				PG16	03026	●	●	●	●	●
25.4	M25				03085	●	●	●	●	●
28.3				PG21	03110	●	●	●	●	●
Die Ø 30.6 - 40.5mm	TYPE IV	30.5			03111	●	●	●	●	●
		32.5	M32		03165	●	●			
		37.0		PG29	03166	●	●			
		40.5	M40		03167	●	●			

PUNCHING WITHOUT PRE-DRILLING

Apress 400

Overhang 400 mm



▶ VIDEO

ALFRA PRESS AP 400 - STATIONARY PUNCHING MACHINE

For rapid punching-out in circular, square, rectangular or special forms without pre-drilling in control cabinet doors, terminal boxes, cable ducts, housings, cable management panels etc. right up to margins. Simple tool change carried out in seconds.

Description:

- Flexible in use – on mobile base
- Rapid tool change helps in problem areas with a wide range of break-through types
- A range of die mountings is available, even for punching very close to margins
- Rows of punch-outs are no problem thanks to attachable folding stops
- Use a laser pointer – no scribing, no centre punching, a simple cross-hair with the pin is sufficient
- Operation using a manual pump is sufficient as a “starter solution” – this makes “punching without pre-drilling” possible at low cost

Technical data:

Overhang with limit stop:	400 mm
Overhang without limit stop:	430 mm
Punching stroke:	50 mm
Punching force F:	46 kN at 600 bar
Hydraulic connection:	R 1/4"
Weight:	220 kg
Space requirement with base approx.:	1,200 x 800 mm

Punching capacity:

Circular from:	Ø 3.2 - 40.5 mm
Square up to:	28.0 x 28.0 mm
Rectangular up to:	22.0 x 30.0 mm
Special forms up to a max. diagonal of:	40.0 mm

Material thicknesses (max):

Sheet steel (S235):	2.5 mm
Stainless steel (F = 600 N/mm ²):	2.0 mm
Aluminium (F = 22 N/mm ²):	4.0 mm
Punchable plastics:	4.0 mm

Prod.-No.

ALFRA PRESS AP 400

03195

Note:

- All circular tools for ALFRA PRESS punchers AP 250 - AP 600 are made of special tool steel and have a special cutting geometry developed by ALFRA

Special tools on request!

Technical features when punching close to margins with die holder Type I

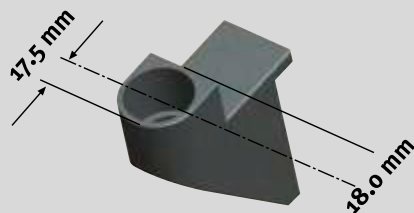

Smallest-possible axial dimension (border spacing) when using die holder Type I

Prod.-No. 03174



Laser pointer for optical display of tool centre and power bank



Die holder Type II



Tool drawer, pivoting



Length and depth limit stop with foldable add-on stops



Pivoting support arms, height adjustable, each with 3 rubber supports



Prod.-No. 03854

We recommend our electro-hydraulic pump AHP S (Prod.-No. 03854) as a drive unit



Prod.-No. 02121

Alternatively, the Alfra stationary hole punchers can be operated with our foot pump Prod.-No. 02121

PUNCHING WITHOUT PRE-DRILLING



Stationary hole puncher – AP 400

Type	Designation	Prod.-No.
Machine	Punching machine ALFRA PRESS 400 with hydraulic cylinder and quick coupling, cylinder piston with non-twist device for insertion of all punch sockets, integrated Laserpointer with power bank, combined length and depth limit stops with 2 adjustable limit stops per axis. The limit stops in the X direction are foldable and are suitable as an add-on limit stop for rows of punch-outs. Pivoting support arms (pairs) height adjustable, each with 2 rubber supports.	03195
Pump	Electro-hydraulic pump AHP S	03854
	Foot switch 2-pedal for electro-hydraulic pump AHP S	03866
Punch socket	with scraper and centring pin Ø 3.2 - 30.5 mm with mounting shaft for AP 250 - 400	03171
	with scraper and centring pin for round puncher Ø 30.6 - 40.5 mm with 19 mm Female thread for AP 250 - 400	03172
Die holder	Type I Dies Ø 3.2 - 22.5 mm for punching right up to margins for AP 250 - 400	03174
	Type II Dies Ø 3.2 - 30.5 mm and moulding tool up to 21 x 21 mm (30.5 mm max. diagonals) for AP 250 - 400	03175
	Type IV Dies Ø 30.6 - 40.5 mm and moulding tool up to 28 x 28 mm (40.0 mm max. diagonals) AP 250 - 400	03176

Square and rectangular hole punches – AP 400

suitable for steel and stainless steel, with mounting shaft and centring point, including die

Type	Designation	Prod.-No.	AP 250	AP 400	AP 500	AP 600
Square holes	21.0 x 21.0 mm for AP 250 - 400	03087	●	●		
	25.4 x 25.4 mm for AP 250 - 400	03088	●	●		
Rectangular holes	22.0 x 30.0 mm for AP 250 - 400	03089	●	●		
Special holes	Ø 22.5 mm with 4 lugs for AP 250 - 400	03086	●	●		
Spare neoprene scraper	for punch socket (03171) Ø 3.2 - 30.5 mm	03185	●	●		
	for punch socket (03172) Ø 30.6 - 40.5 mm	03186	●	●		

ALFRA PRESS AP 400 - STATIONARY PUNCHING MACHINE

Circular punches and dies – AP 400 suitable for steel and stainless steel										
Type	Mounting holder	Ø in mm	Size Metric	Size PG	Prod.-No.	AP 250	AP 400	AP 500	AP600	AP 800
Punch Ø 3.2 - 30.5 mm		3.2			03131	●	●	●	●	●
		4.5			03132	●	●	●	●	●
		5.4			03133	●	●	●	●	●
		6.5			03134	●	●	●	●	●
		8.5	M8		03135	●	●	●	●	●
		10.5	M10		03136	●	●	●	●	●
		12.7	M12	PG7	03137	●	●	●	●	●
		15.2		PG9	03138	●	●	●	●	●
		16.2	M16		03139	●	●	●	●	●
		18.6		PG11	03140	●	●	●	●	●
		20.4	M20	PG13	03141	●	●	●	●	●
		22.5		PG16	03142	●	●	●	●	●
		25.4	M25		03143	●	●	●	●	●
		28.3		PG21	03144	●	●	●	●	●
Punch Ø 32.5 - 40.5 mm		30.5			03145	●	●	●	●	●
		32.5	M32		03146	●	●	●	●	●
		37.0		PG29	03158	●	●	●	●	●
Die Ø 3.2 - 22.5 mm	TYPE I	40.5	M40		03147	●	●	●	●	●
		3.2			03500	●	●			
		4.5			03501	●	●			
		5.4			03502	●	●			
		6.5			03503	●	●			
		8.5	M8		03504	●	●			
		10.5	M10		03505	●	●			
		12.7	M12	PG7	03506	●	●			
		15.2		PG9	03507	●	●			
		16.2	M16		03508	●	●			
		18.6		PG11	03509	●	●			
		20.4	M20	PG13	03510	●	●			
		22.5		PG16	03511	●	●			
		Die Ø 3.2 - 30.5 mm	TYPE II	3.2			03063	●	●	●
4.5					03066	●	●	●	●	●
5.4					03068	●	●	●	●	●
6.5					03074	●	●	●	●	●
8.5	M8				03076	●	●	●	●	●
10.5	M10				03079	●	●	●	●	●
12.7	M12			PG7	03022	●	●	●	●	●
15.2				PG9	03023	●	●	●	●	●
16.2	M16				03084	●	●	●	●	●
18.6				PG11	03024	●	●	●	●	●
20.4	M20			PG13	03025	●	●	●	●	●
22.5				PG16	03026	●	●	●	●	●
25.4	M25				03085	●	●	●	●	●
28.3				PG21	03110	●	●	●	●	●
Die Ø 30.6 - 40.5mm	TYPE IV	30.5			03111	●	●	●	●	●
		32.5	M32		03165	●	●			
		37.0		PG29	03166	●	●			
		40.5	M40		03167	●	●			

PUNCHING WITHOUT PRE-DRILLING

Apress 600

Overhang 600 mm



▶ VIDEO

ALFRA PRESS AP 600 - STATIONARY PUNCHING MACHINE

The stationary punching machine has been developed for control cabinet and switch gear makers and is suitable for quick punching-out of circular, square, rectangular or special forms in sheet metal and control cabinet doors up to 2200 mm x 1000 mm and 30 mm margin fold height. Punching possible right up to margins.

Simple, rapid tool change carried out in seconds – even on fitted door.
Limit stop system can be moved in X and Y directions.

Description:

- Stable press body in heavy-duty, torsionally-stiff welded construction
- Dual-action hydraulic cylinder, flanged force-locking and form-locking to machine body
- Anti-twist piston rod \varnothing 55 mm made of tempered stainless steel with tool holder
- Die bed, fixed force-locking to press body
- Rapid tool change helps in problem areas with a wide range of break-through types
- Hold-down device with safety function, fixed with electrical safety lock for accident prevention
- Length and depth limit stops movable in X and Y directions, bearings in hardened double ball bearing slides for smooth mobility
- Tape measure display for length and depth adjustment
- Digital measuring indicator for X and Y axes
- Dual-circuit hydraulic unit with electric pump, oil container and solenoid valves (very low noise)
- Safety footswitch with double pedal for infinitely variable operation of punching and return stroke

Technical data:

Overhang with limit stop:	600 mm
Punching stroke:	66 mm
Punching force F:	60 kN at 165 bar
Motor power:	0.75 kW
Operating voltage:	400 V
Weight approx.:	360 kg
Overall height:	1,600 mm
Working height:	1,000 mm
Width of puncher body:	310 mm
Depth of puncher body:	1,150 mm
Length of limit stock rails:	1,500 mm
Space requirement approx.:	2,000 x 3,000 mm

Punching capacity:

Circular from:	\varnothing 3.2 - 70.0 mm
Square up to:	68.0 x 68.0 mm
Special forms up to a max. diagonal of:	90.0 mm

Material thicknesses (max):

Sheet steel (S235):	3.0 mm
Stainless steel ($F = 600 \text{ N/mm}^2$):	2.0 mm
Aluminium ($F = 22 \text{ N/mm}^2$):	4.0 mm
Punchable plastics up to:	4.0 mm

Prod.-No.
03090

ALFRA PRESS AP 600

Note:

- All circular tools for ALFRA PRESS punching machines AP 250 - AP 600 are made of special tool steel and have a special cutting geometry developed by ALFRA

Special tools on request!

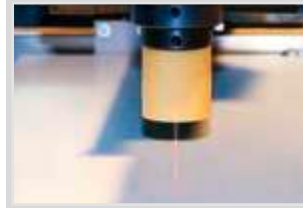

Laser pointer for optical display of tool centre

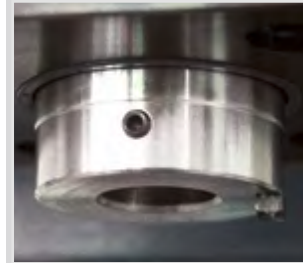

Stable piston rod (\varnothing 55 mm) with tool anti-twist device



Tool drawer with compartments



Dual-circuit hydraulic unit in cabinet base



Reciprocal quick-clamping system for edge folds either top or bottom



Die bed holder. Tool changes can also be carried out when control cabinet door is fitted



Length and depth limit stops guided in double ball bearing slides on both sides. 2 adjustable limit stops right and left on the Y-axis

PUNCHING WITHOUT PRE-DRILLING

ALFRA PRESS 600

Overhang 600 mm

Stationary hole puncher – AP 600		
Type	Designation	Prod.-No.
Machine	Stationary punching machine ALFRA PRESS 600 with hydraulic cylinder, cabinet base, length and depth limit stops movable in X and Y directions, cylinder pistons with anti-twist device for use with all punch sockets, dual-action hydraulic unit, safety footswitch, Laser pointer for optical display of tool centre, Digital measuring indicator Y-axis, Digital measuring indicator X-axis, Pivoting double joint arm for supporting workpiece	03090
Punch socket	with scraper and centring pin for round puncher with mounting shaft for AP 500 - 600 Ø 3.2 - 30.5 mm	03036
	with centring pin for round puncher with 19 mm female thread for AP 500 - 600 Ø 32.5 - 63.5 mm	03035
Die holder	Type A Circular die Type A Ø 3.2 - 25.4 mm	03040
	Type B Circular die Type A Ø 28.3 - 40.5 mm	03041
	Type C Circular die Type A Ø 40.6 - 63.5 mm	03077

Square and rectangular hole punches – AP 600 suitable for steel and stainless steel, with mounting shaft and centring point, including die						
Type	Designation	Prod.-No.	AP 250	AP 400	AP 500	AP 600
Square holes	12.7 x 12.7 mm for AP 500 - 600	03042			●	●
	19.0 x 19.0 mm for AP 500 - 600	03044			●	●
	22.2 x 22.2 mm for AP 500 - 600	03045			●	●
	25.4 x 25.4 mm for AP 500 - 600	03046			●	●
	46.0 x 46.0 mm for AP 500 - 600	03047			●	●
	68.0 x 68.0 mm for AP 600	03050				●
Rectangular holes	22.0 x 30.0 mm for AP 500 - 600	03048			●	●
	22.0 x 42.0 mm for AP 500 - 600	03049			●	●
Special holes	Ø 22.5 mm 1 lug 3.2 mm for AP 500 - 600	03051			●	●
	Ø 22.5 mm with 2 lugs 3.2 mm for AP 500 - 600	03052			●	●
	Ø 22.5 mm, flattened on 4 sides to 20.1 mm for AP 500 - 600	03055			●	●

ALFRA PRESS AP 600 - STATIONARY PUNCHING MACHINE

Circular punches and dies – AP 600 suitable for steel and stainless steel										
Type	Mounting holder	Ø in mm	Size Metric	Size PG	Prod.-No.	AP 250	AP 400	AP 500	AP 600	AP 800
Punch Ø 3.2 - 30.5 mm		3.2			03131	●	●	●	●	●
		4.5			03132	●	●	●	●	●
		5.4			03133	●	●	●	●	●
		6.5			03134	●	●	●	●	●
		8.5	M8		03135	●	●	●	●	●
		10.5	M10		03136	●	●	●	●	●
		12.7	M12	PG7	03137	●	●	●	●	●
		15.2		PG9	03138	●	●	●	●	●
		16.2	M16		03139	●	●	●	●	●
		18.6		PG11	03140	●	●	●	●	●
		20.4	M20	PG13	03141	●	●	●	●	●
		22.5		PG16	03142	●	●	●	●	●
		25.4	M25		03143	●	●	●	●	●
		28.3		PG21	03144	●	●	●	●	●
		30.5			03145	●	●	●	●	●
Punch Ø 32.5-63.5 mm		32.5	M32		03146	●	●	●	●	●
		37.0		PG29	03158	●	●	●	●	●
		40.5	M40		03147	●	●	●	●	●
		47.0		PG36	03159			●	●	●
		50.5	M50		03148			●	●	●
		54.0		PG42	03160			●	●	●
		60.0		PG48	03161			●	●	●
		63.5	M63		03149			●	●	●
Die Ø 3.2 - 25.4 mm	TYPE A	3.2			03063	●	●	●	●	●
		4.5			03066	●	●	●	●	●
		5.4			03068	●	●	●	●	●
		6.5			03074	●	●	●	●	●
		8.5	M8		03076	●	●	●	●	●
		10.5	M10		03079	●	●	●	●	●
		12.7	M12	PG7	03022	●	●	●	●	●
		15.2		PG9	03023	●	●	●	●	●
		16.2	M16		03084	●	●	●	●	●
		18.6		PG11	03024	●	●	●	●	●
		20.4	M20	PG13	03025	●	●	●	●	●
		22.5		PG16	03026	●	●	●	●	●
		25.4	M25		03085	●	●	●	●	●
Die Ø 28.3 - 40.5 mm	TYPE B	28.3		PG21	03027			●	●	●
		30.5			03028			●	●	●
		32.5	M32		03163			●	●	●
		37.0		PG29	03029			●	●	●
		40.5	M40		03164			●	●	●
Die Ø 47.0 - 63.5 mm	TYPE C	47.0		PG36	03030			●	●	●
		50.5	M50		03168			●	●	●
		54.0			03031			●	●	●
		60.0		PG48	03032			●	●	●
		63.5	M63		03169			●	●	●

APPLICATION SOLUTIONS FOR STEEL AND METAL CONSTRUCTION

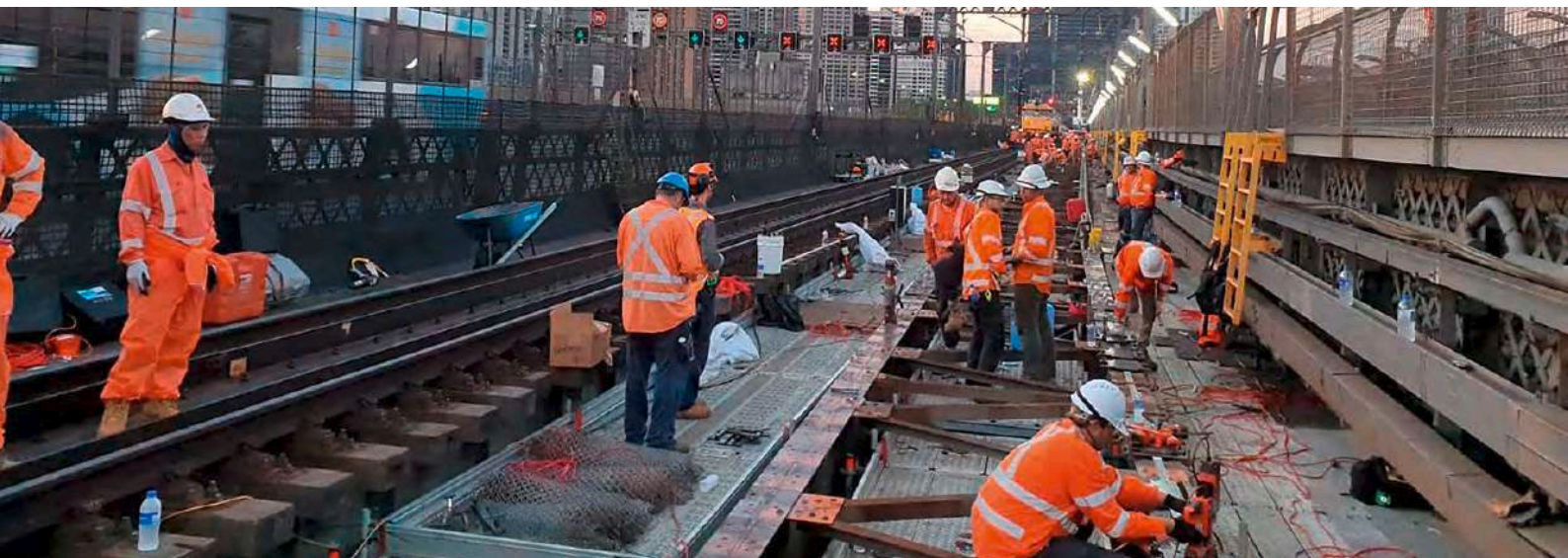

DRILLING

Tough as nails – our core drilling machines and drilling accessories



Core drilling machines from Alfa are uncompromising machines with performance-based – just like the Metalworking accessories and magnet chipping. Immerse yourself in our product worlds for all things drilling and drilling accessories.

- Robust core drilling electromagnet
- Core drilling machines with permanent for safe drilling in any position
- HSS and carbide core drills with high-performance toothing
- Adapters for various combinations

CUTTING TOOLS

Hole saws and multi-step drills for almost all materials



Show new, challenging projects teeth – with Alfa hole saws and multi-level drilling. Stainless steel, unalloyed steels, aluminium, plastic or lightweight boards are no problem for our robust endurance runners.

- Centring, spot drilling, reaming and the deburring in one operation? Our Alfa multistage drills are multi-talents
- When things have to run smoothly: Carbide Hole saws with tapered centre bit for drilling without centre punching
- From 31.0 mm diameter with specially hardened Morse taper holder.
- No premature shearing of the holder shaft because the design compensates for torsional forces during heavy use.

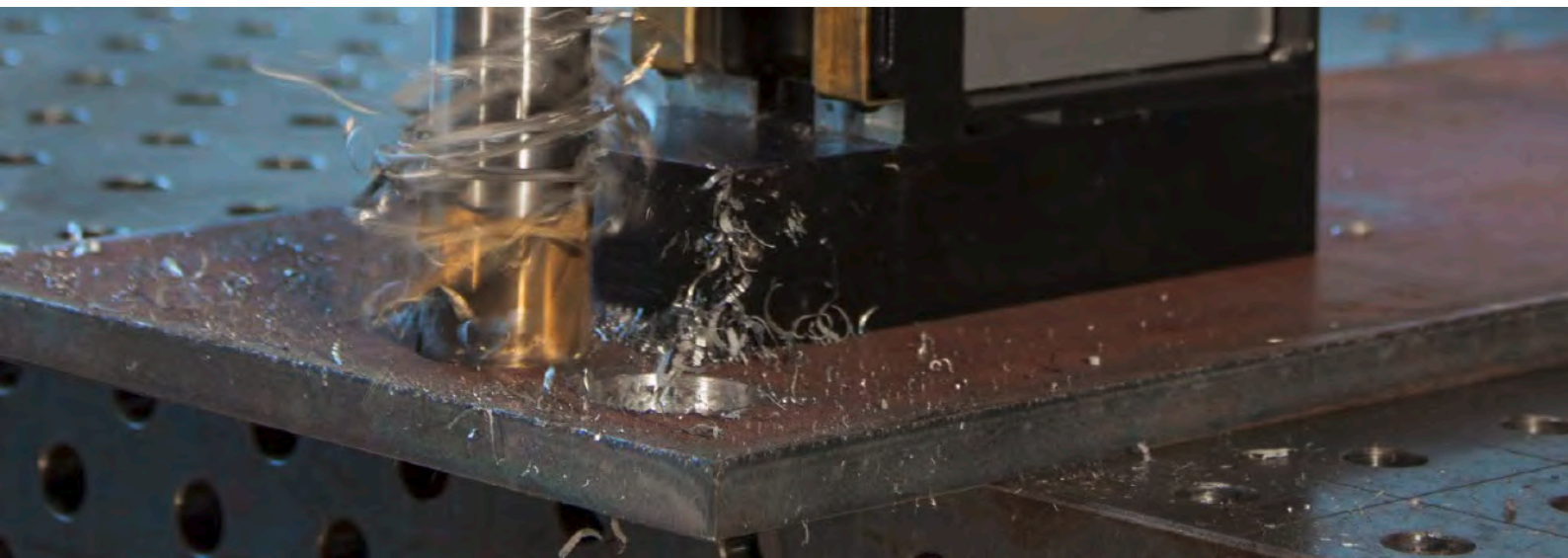

PUNCHING

Low-noise, fully automatic punching of T-beams and steel plates



„Clack!“ That’s all you hear when our hydraulic punches make round and slotted holes in steel beams or heavy metal plates in just one work step. The powerhouses APS 70 and APS 120 operate at 700 bar working pressure and get the job done in seconds. And the best thing is that despite all this power, they are still mobile - for example, for use on your projects in steel and metal construction, bridge building or tank construction. The high-performance punches are perfect in a team with the right accessories.

- Strong in use on steel plates or beams up to 16 mm thick
- Available in jaw depths of 70 mm and 110 mm
- Unbeatable in team with our hydraulic pumps as drive
- Punches and dies from our own production
- Effortless positioning of the punches with the Serviceboy

THE ALFRA-ROTABEST®-FAMILY – METAL CORE DRILLING IN EVERY POSITION



B-LINE

The solid ones with the strong price

The models from our Alfa Basic-line are real endurance runners. Unbeatable when it comes to service life, they are also standing out because of an exceptional price-performance. These advantages are delivering you to the line.

- Our Basic-line is combining proven Alfa-quality with an attractive purchase price. So you get good value for money and you remain economically flexible.
- No matter how many hours a core drilling machine from the Basic-line is in use for your business – the device is going to complete the task steadily. The winning combination: sturdiness and precision.
- Our Rotabest 130 B – when size matters. The XXL Version amongst our Alfa core drilling machines is the perfect match for metalworkers, who need more: More power, more drillhole diameter, more cutting depth. For cutting depths up to 130 mm.
- Core drill dimensions-Ø: 12 - 130 mm



RL-E-LINE

The robust ones with the twist

The Rotabest models from the RL-E-line can do better than merely drilling holes. Because the solid ones with right/left run do not only work precisely, they are tapping threads, too. Furthermore they are very user friendly.

- Our professional line with right/left run for metal workers includes two reliable working devices with left/right run for coredrilling, thread tapping, counterboring and spiral drilling.
- Available in three variants: for drill diameters up to 50 mm, 80 mm, 100 mm and 130 mm
- All at a glance: the clear operating concept is self-explanatory. Confusion or application errors are almost excluded.
- Core drill dimensions-Ø: 12 - 130 mm



SP-LINE



The independent ones with permanent magnet

How do you imagine your ideal partner? Reliable in every situation and still independent? Then our core drilling machines from the SP-line are the perfect match for you. The basis: the patented permanent magnet with a safety sensor adheres horizontal and vertical, autonomous from power supply. Crashes are nearly impossible – and more: our premium products are holding nicely in your hand, too.

- Our premium line is convincing due to a permanent magnet with safety sensor to check the holding force – for maximum occupational safety.
- because of the patented magnetics technology the drill stand adheres from only 3 mm material thickness – for applications in every position.
- Hard facts, soft factors – the models from the SP-line are unifying all performance characteristics of metal core drilling with an ergonomically optimized operating comfort and sophisticated equipment.
- Core drill dimensions-Ø: 12 - 50 mm

V-LINE



The duo for special operations

The “V” in the name says it all: Core drilling machines belonging to our V-LINE are specialists – for example when things are literally getting tight. May we present: our super-heroes for particular challenges.

- V 40: flat design for high demands. The compact model is operating at full capacity even in working areas which are difficult to access. For example when it comes to drilling close to vehicle frames, inside narrow T-beams and when core drilling machines with standard measures are running into their limits.

- SP-V: One for all: the slimly designed drill stand SP-V with a permanent magnet is adhering from a material thickness of only 3 mm. Furthermore: Due to the 43 mm Euro standard collar, the lightweight is combinable with a broad variety of core drilling machines
- You haven't found what you've been looking for? There's a suitable core drilling machine for every challenging project. Please don't hesitate to ask for further solutions for your special applications.
- Core drill dimensions-Ø: 12 - 40 mm
- More Dimensions

B-LINE

	Ø35		Ø50	Ø80	Ø130
					
					
	RB 35 B	RB 35/50 B PICCOLO	RB 50 B	RB 80 B	RB 130 B
Page	86 - 87		89	90	91
Prod.-No.	230 V: 18400 110 V: 18400.110		230 V: 18451 110 V: 18451.110	230 V: 18481 110 V: 18481.110	230 V: 18646
Core drill dimensions	Ø 12.0 - 35.0 mm		Ø 12.0 - 50.0 mm	Ø 12.0 - 80.0 mm / Ø 20.0 - 50.0 mm (cutting depth 110 mm)	Ø 12.0 - 130.0 mm / Ø 20.0 - 50.0 mm (cutting depth 110 mm)
Cutting depth	50.0 mm		50.0 mm	50.0 mm / 110.0 mm	50.0 mm / 110.0 mm
Twist drill	Ø 1.0 - 13.0 mm DIN 1897 short	Ø 1.0 - 13.0 mm DIN 1897 short	Ø 1.0 to 16.0 mm with quick-release chuck MT2 up to Ø 20.0 mm with MT2 DIN 345 direct	Ø 1.0 - 16.0 mm with drill chuck up to Ø 32.0 mm with MT3 DIN 345	up to Ø 45.0 mm with MT4 DIN 345
Counterboring	Ø 10.0 - 40.0 mm		Ø 10.0 - 40.0 mm	Ø 10.0 - 55.0 mm	Ø 10.0 - 80.0 mm
Tapping	-		with tapping attachment: M3 - M20	with tapping attachment: up to M30	with tapping attachment: up to M42
Arbor	19 mm Weldon shank		MT2	MT3	MT4
Stroke	120 mm		190 mm	190 mm	230 mm
Height adjustment	-		100 mm	100 mm	100 mm
Gearbox – on-load speed	450 rpm		1. Step 250 rpm 2. Step 450 rpm	1. Step 110 rpm 2. Step 175 rpm 3. Step 245 rpm 4. Step 385 rpm	1. Step 30 - 80 rpm 2. Step 50 - 120 rpm 3. Step 130 - 350 rpm 4. Step 210 - 550 rpm
Power consumption	1,100 W		1,200 W	1,800 W	2,500 W
Voltage	230 V 50/60 Hz 110 V 50/60 Hz		230 V 50/60 Hz 110 V 50/60 Hz	230 V 50/60 Hz 110 V 50/60 Hz	230 V 50/60 Hz
Magnetic holding force	10,000 N		12,000 N	16,000 N	33,000 N
Tool-Force (10 mm)*	2,100 N		3,500 N	4,000 N	5,000 N
Min. material thickness	6 mm		6 mm	10 mm	10 mm
Magnetic base	70 x 185 mm		92 x 220 mm	92 x 220 mm	90 x 400 mm
Weight	10.6 kg		15.0 kg	21.3 kg	37.0 kg
Motor					
Oil bath gearbox	-		✓	✓	✓
Mechanical slipping clutch	-		-	✓	✓
Slide					
Stepless adjustment	-		✓	✓	-
Self-adjusting guide	✓		✓	✓	-
Operation					
Soft-touch grips	✓		✓	✓	✓
Ergonomic switch keyboard	✓		✓	✓	✓
Cord length 5 m	✓		✓	✓	✓
Magnet					
Sensor/LED	-		-	✓	-
Metal rings	✓		✓	✓	✓

* Lift-off force directly on the tool/core drill machine

RL-E-LINE

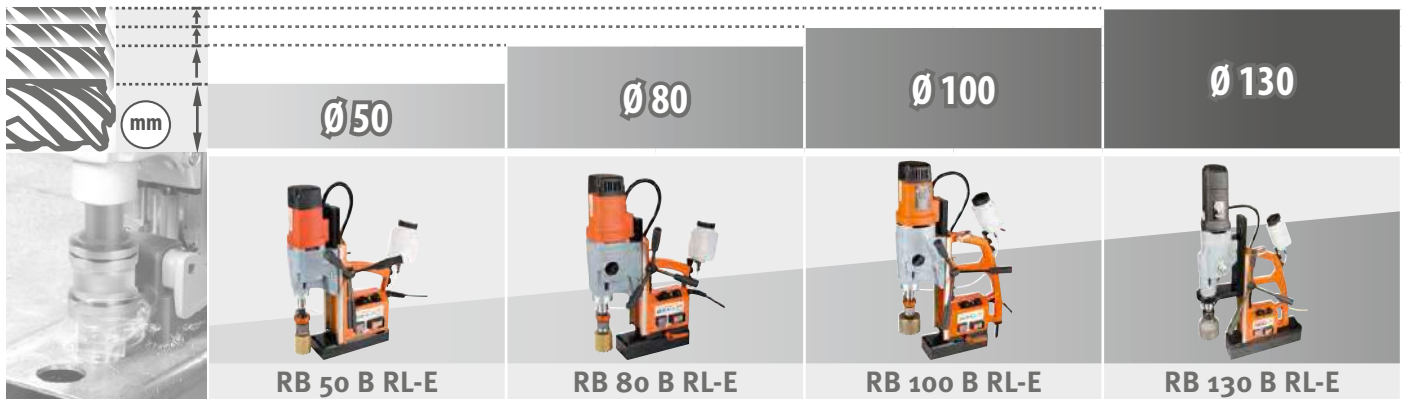

	Ø 50	Ø 80	Ø 100	Ø 130
Page	92	93	94	95
Prod.-No.	230 V: 18612 110 V: 18612.110	230 V: 18629 110 V: 18629.110	230 V: 18636 110 V: 18636.110	230 V: 18647 110 V: 18647.110
Core drill dimensions	Ø 12.0 - 50.0 mm	Ø 12.0 - 80.0 mm / Ø 20.0 - 50.0 mm (cutting depth 110 mm)	Ø 12.0 - 100.0 mm / Ø 20.0 - 50.0 mm (cutting depth 110 mm)	Ø 12.0 - 130.0 mm / Ø 20.0 - 50.0 mm (cutting depth 110 mm)
Cutting depth	50.0 mm	50.0 mm / 110.0 mm	50.0 mm / 110.0 mm	50.0 mm / 110.0 mm
Twist drill	Ø 1.0 bis 16.0 mm with quick-release chuck MT2 up to Ø 20.0 mm with MT2 DIN 345 direct	Ø 1.0 - 16.0 mm with drill chuck up to Ø 32.0 mm with MT3 DIN 345	Ø 1.0 - 16.0 mm with drill chuck up to Ø 32.0 mm with MT3 DIN 345	up to Ø 45.0 mm with MT4 DIN 345
Counterboring	Ø 10.0 - 40.0 mm	Ø 10.0 - 55.0 mm	Ø 10.0 - 55.0 mm	Ø 10.0 - 80.0 mm
Tapping	with tapping chucks: M3 - M14 with tapping attachment: M3 - M20	with tapping chucks: up to M30 with tapping attachment: up to M30	with tapping chucks: up to M30 with tapping attachment: up to M30	with tapping attachment: up to M42
Arbor	MT2	MT3	MT3	MT4
Stroke	170 mm	190 mm	245 mm	230 mm
Height adjustment	100 mm	60 mm	116 mm	100 mm
Gearbox - on-load speed	right/left 1. Step 100 - 250 rpm 2. Step 180 - 450 rpm	right/left 1. Step 50 - 110 rpm 2. Step 75 - 175 rpm 3. Step 105 - 245 rpm 4. Step 165 - 385 rpm	right/left 1. Step 50 - 150 rpm 2. Step 75 - 230 rpm 3. Step 100 - 310 rpm 4. Step 160 - 490 rpm	right/left 1. Step 30 - 80 rpm 2. Step 50 - 120 rpm 3. Step 130 - 350 rpm 4. Step 210 - 550 rpm
Power consumption	1,200 W	1,800 W	2,500 W (230 V) 2,400 W (110 V)	2,500 W
Voltage	230 V 50/60 Hz 110 V 50/60 Hz	230 V 50/60 Hz 110 V 50/60 Hz	230 V 50/60 Hz 110 V 50/60 Hz	230 V 50/60 Hz 110 V 50/60 Hz
Magnetic holding force	16,000 N	20,000 N	20,000 N	33,000 N
Tool-Force (10 mm)*	3,800 N	4,200 N	4,000 N	5,000 N
Min. material thickness	10 mm	10 mm	10 mm	10 mm
Magnetic base	92 x 238 mm	92 x 238 mm, 30° adjustable right and left, 10 mm front and back	92 x 238 mm, 30° adjustable right and left, 10 mm front and back	90 x 400 mm
Weight	16.0 kg	22.0 kg	28.0 kg	37.0 kg

Motor

Right/left run	✓	✓	✓	✓
Full-wave control electronics	-	-	✓	✓
Smooth start	-	-	✓	-
Overload protection	-	-	✓	-
Motor emergency stop	-	-	-	-
Oil bath gearbox	✓	✓	✓	✓
Mechanical slipping clutch	-	✓	✓	✓

Slide

Stepless adjustment	✓	✓	✓	✓
---------------------	---	---	---	---

Operation

Soft-touch grips	✓	✓	✓	✓
Ergonomic switch keyboard	✓	✓	✓	✓
Cord length 5 m	✓	✓	✓	✓

Magnet

Sensor/LED	-	-	-	-
Metal rings	✓	✓	✓	✓

* Lift-off force directly on the tool/core drill machine

SP-LINE



Ø35



RB 35 SP

Ø 50



RB 50 SP

Page	96 - 97		98	
Prod.-No.	230 V: 18801	110 V: 18801.110	230 V: 18851	110 V: 18851.110
Core drill dimensions	Ø 12.0 - 35.0 mm		Ø 12.0 - 50.0 mm	
Cutting depth	50.0 mm		50.0 mm	
Twist drill	Ø 1.0 - 13.0 mm		Ø 1.0 - 20.0 mm	
Counterboring	Ø 10.0 - 40.0 mm		Ø 10.0 - 40.0 mm	
Tapping	-		-	
Arbor	Quick-release chuck		MT2	
Stroke	105 mm		100 mm	
Height adjustment	80 mm		47 mm	
Gearbox - on-load speed	450 rpm		1. Step 250 rpm 2. Step 450 rpm	
Power consumption	1,100 W		1,200 W	
Voltage	230 V 50/60 Hz 110 V 50/60 Hz		230 V 50/60 Hz 110 V 50/60 Hz	
Magnetic holding force	17,000 N		17,000 N	
Tool-Force (10 mm)*	2,800 N		2,800 N	
Min. material thickness	from 3 mm		from 3 mm	
Magnetic base	72 x 190 mm		72 x 190 mm	
Weight	9.9 kg		11.5 kg	
Motor				
Smooth start	✓		✓	
Hybrid relay	✓		✓	
Right/left run	-		-	
Overload protection	✓		✓	
Motor emergency stop	✓		✓	
Oil bath gearbox	-		✓	
Mechanical slipping clutch	-		-	
Slide				
Stepless adjustment	✓		✓	
Self-adjusting guide	✓		✓	
Operation				
Soft-touch grips	✓		✓	
Membrane keyboard	✓		✓	
Holder for Allen key	✓		✓	
Cord length 5 m	✓		✓	
Magnet				
Sensor/LED	✓		✓	
Permanent magnet	✓		✓	
TiN-coating	✓		✓	

* Lift-off force directly on the tool/core drill machine

V-LINE

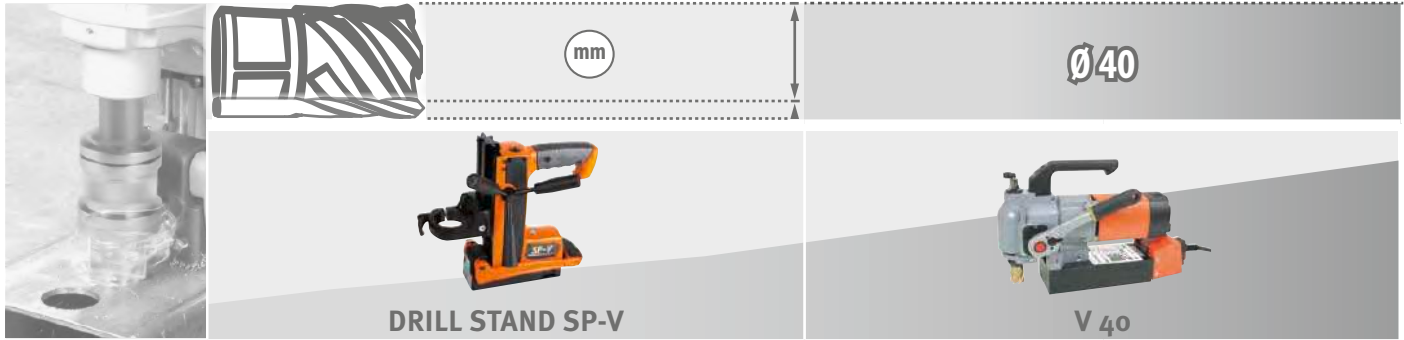

Page	100 - 101	99
Prod.-No.	18343	230 V: 18712 110 V: 18712.110
Core drill dimensions	-	Ø 12.0 - 40.0 mm
Cutting depth	-	30.0 mm
Twist drill	Ø depending on the respective drilling machine used	
Counterboring	-	Ø 10.0 - 32.0 mm
Tapping	-	-
Arbor	Ø 43 mm Euro Neck, Ø 48.6 mm Ø 61.7 mm	19 mm Weldon shank
Stroke	105 mm	45 mm
Height adjustment	80 mm	-
Gearbox – on-load speed	-	450 rpm
Power consumption	-	900 W
Voltage	-	230 V 50/60 Hz 110 V 50/60 Hz
Magnetic holding force	17,000 N	16,000 N
Tool-Force (10 mm)*	2,800 N	2,100 N
Min. material thickness	from 3 mm	6 mm
Magnetic base	72 x 190 mm	95 x 200 mm
Weight	6.8 kg	12.5 kg

Motor		
Smooth start	-	Compact, lying
Hybrid relay	-	
Full-wave control electronics	-	
Right/left run	-	
Overload protection	-	
Motor emergency stop	-	
Oil bath gearbox	-	
Mechanical slipping clutch	-	
Slide		
Stepless adjustment	-	2-sided column guide
Self-adjusting guide	-	
Operation		
Soft-touch grip	✓	Space-saving – through ratchet
Membrane keyboard	-	
Holder for Allen key	-	
Cord length 5 m	-	
Magnet		
Metal rings	-	✓
TiN-coating	✓	-

* Lift-off force directly on the tool/core drill machine

Core drilling with

ALFRA ROTABEST®



POWER GLOSSARY

Motor	
1 Temperature sensor	The LED signal informs about a motor overheating due to overload. After cooling down, the motor can be activated again.
2 Carbon brush wear control	The motor LED flashes as soon as the carbon brushes are worn through mechanical abrasion. The motor continues to run.
3 Drive unit	Height adjustable allows a larger, multiple stroke range.
4 Smooth start	Protects the motor and extends its lifetime.
5 PUR Control line	Remains flexible even at low temperatures and is optimally protected against external influences.
Gearboxes	
6 Special gearbox	The wear of the gearbox wheels is reduced significantly even under extreme conditions.
Operation	
7 Soft-touch grips	Abrasion resistant for perfect grip. Including integrated Allen key tray
8 Double dovetail slide	Self-adjusting through innovative clamping system

Operation	
9 Activation lever for magnet	Ergonomic and easy to use. With perforated grip zone for perfect grip.
10 5 metre PUR connection cable	Remains flexible even at low temperatures and is optimally protected against external influences.
11 Membrane keyboard	The keypad has been ergonomically designed and further offset in the housing so that it is less sensitive to moisture and mechanical influences.
12 Circuit board with hybrid relay	Extra long life. Voltage spikes are intercepted.
13 Quick-release chuck	Weight-optimised to reduce the imbalance to a minimum. Is compatible for all core drills with standard Weldon arbor.
Permanent magnet	
14 Permanent magnet	100% reliability (also in case of power failure) - already can be used from 3 mm thickness
15 LED for magnetic/adhesive power indicator	This shows various function statuses - "continuous green" for OK - "red flashing" with holding force which is just sufficient - "continuous red" with low holding force - (motor turns off automatically)
16 TiN coated magnetic undersurface	Scratch-resistant and resistant to external influences.

ALFRA MAGNET TECHNOLOGY



LIFTING



CORE DRILLING

ALFRA sets new standards in magnet technology!

Our Permanent Magnets are activated according to a patented principle, completely independent of the mains supply—providing safety and permanent stability!

ALFRA is the worldwide license holder for the new, patented magnetic system that allows you to drill, lift, position, transport...from a material thickness of just 1 mm (1/32")!



POSITIONING



US Patent No.
8350663B1



 MADE IN GERMANY



SPECIAL / PROBLEM SOLUTIONS



“For our tests, we drilled holes in a 16 mm thick structural steel plate and a 140 mm thick T-beam. I can conclude by saying that I have rarely enjoyed drilling with large diameters so much. Working with the Rotabest RB 35 B is easier than ever before.”

Jörg Uelkesforth
Technical editor,
Motor & Maschine 1/2020



 PDF

ALFRA ROTABEST® – RB 35 B

B-LINE

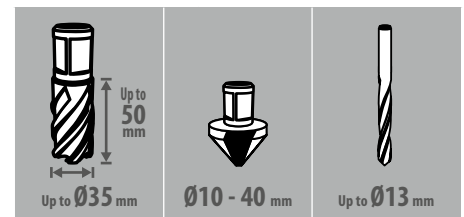

RB 35 B

Core drill dimensions	Ø 12.0 - 35.0 mm
Cutting depth	50.0 mm
Twist drill	Ø 1.0 - 13.0 mm DIN 1897 short
Counterboring	Ø 10.0 - 40.0 mm
Arbors	19 mm Weldon shank
Stroke	120 mm
Gearbox - on-load speed	450 rpm
Power consumption	1,100 W
Voltage	230 V 50/60 Hz 110 V 50/60 Hz
Magnetic adhesion strength	10,000 N
Tool force (10 mm)	2,100 N
Magnetic base	70 x 185 mm
Weight	10.6 kg

Slide	
Self-adjusting guide	✓
Operation	
Soft-touch grips	✓
Ergonomic switch keyboard	✓
Cable length 5 m	✓
Magnet	
Metal rings	✓
Performance and weight optimisation	✓

Scope of delivery	
<ul style="list-style-type: none"> • Metal core drilling machine RB 35 B • Coolant device • Carrying case • Seat belt • Operating Instructions • incl. 1 core drill free 	

Prod.-No.

ALFRA Rotabest® RB 35 B	230 Volt	18400
ALFRA Rotabest® RB 35 B	110 Volt	18400.110

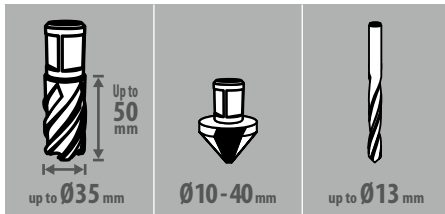

RB 35/50 B PICCOLO

Core drill dimensions	Ø 12.0 - 35.0 mm
Cutting depth	50.0 mm
Twist drill	Ø 1.0 - 13.0 mm
Counterboring	Ø 10.0 - 40.0 mm
Arbors	19 mm Weldon shank
Stroke	129 mm
Height adjustment	86 mm
Gearbox – on-load speed	450 U/min,
Power consumption	1,100 W
Voltage	230 V 50/60 Hz 110 V 50/60 Hz
Magnetic adhesion strength	10,000 N
Tool force (10 mm)	2,100 N
Magnetic base	70 x 185 mm
Weight	11.5 kg

Motor	
Grease drive	✓
Slides	
Infinitely adjustable	✓
Self-adjusting guide	✓
Operation	
Soft-touch grips	✓
Ergonomic switch keyboard	✓
Cable length 5 m	✓
Magnet	
Metal rings	✓
Performance and weight optimisation	✓

Scope of delivery	
<ul style="list-style-type: none"> • Metal core drilling machine RB 35/50 B Piccolo • Coolant device • Carrying case • Seat belt • Operating Instructions 	



ALFRA Rotabest® RB 35/50 B Piccolo 230 Volt
ALFRA Rotabest® RB 35/50 B Piccolo 110 Volt

Prod.-No.

18401

18401.110

ALFRA ROTABEST® – RB 50 B

B-LINE

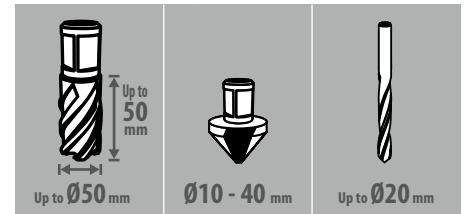

RB 50 B

Core drill dimensions	Ø 12.0 - 50.0 mm
Cutting depth	50.0 mm
Twist drill	Ø 1.0 to 16.0 mm with quick-release chuck MT2 up to Ø 20.0 mm with MT 2 DIN 345 direct
Counterboring	Ø 10.0 - 40.0 mm
Tapping	with tapping attachment M3 - M20
Arbors	MT2
Stroke	190 mm
Height adjustment	100 mm
2-speed gearbox Load speed	1. Step 250 rpm 2. Step 450 rpm
Power consumption	1,200 W
Voltage	230 V 50/60 Hz 110 V 50/60 Hz
Magnetic adhesion strength	12,000 N
Tool force (10 mm)	3,500 N
Magnetic base	92 x 220 mm
Weight	15.0 kg

Motor	
Oil bath gearbox	✓
Slides	
Infinitely adjustable	✓
Self-adjusting guide	✓
Operation	
Soft-touch grips	✓
Ergonomic switch keyboard	✓
Cable length 5 m	✓
Magnet	
Metal rings	✓
Performance and weight optimisation	✓

Scope of delivery

- Metal core drilling machine RB 50 B
- Coolant device
- MT2 tool holder with internal cooling
- Carrying case
- Drill spray
- Seat belt
- Operating Instructions
- **incl. 1 core drill free**

Prod.-No.

ALFRA Rotabest® RB 50 B	230 Volt	18451
ALFRA Rotabest® RB 50 B	110 Volt	18451.110

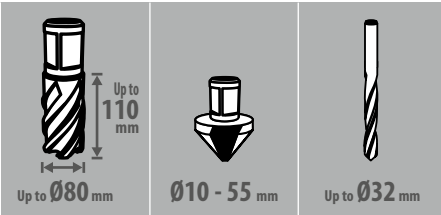

RB 80 B

Core drill dimensions	Ø 12.0 - 80.0 mm / Ø 20.0 - 50.0 mm (cutting depth 110 mm)
Cutting depth	50.0 mm / 110.0 mm
Twist drill	Ø 1.0 - 16.0 mm with drill chuck Up to Ø 32.0 mm with MT3 DIN 345
Counterboring	Ø 10 - 55.0 mm
Tapping	with tapping attachment: Up to M30
Arbors	MT3
Stroke	190 mm
Height adjustment	100 mm
4-speed gearbox Load speed	1. Step 110 rpm 2. Step 175 rpm 3. Step 245 rpm 4. Step 385 rpm
Power consumption	1,800 W
Voltage	230 V 50/60 Hz 110 V 50/60 Hz
Magnetic adhesion strength	16,000 N
Tool force (10 mm)	4,000 N
Magnetic base	92 x 220 mm
Weight	21.3 kg

Motor	
Motor emergency stop	✓
Oil bath gearbox	✓
Mech. Slip clutch	✓
Slides	
Infinitely adjustable	✓
Self-adjusting guide	✓
Operation	
Soft-touch grips	✓
Ergonomic switch keyboard	✓
Cable length 5 m	✓
Magnet	
Sensor/LED	✓
Metal rings	✓
Performance and weight optimisation	✓

Scope of delivery	
<ul style="list-style-type: none"> • Metal core drilling machine RB 80 B • Coolant device • MT3 tool holder with internal cooling • Carrying case • Drill spray • Seat belt • Operating Instructions • incl. 1 core drill free 	



Prod.-No.

ALFRA Rotabest® RB 80 B	230 Volt	18481
ALFRA Rotabest® RB 80 B	110 Volt	18481.110

ALFRA ROTABEST® – RB 130 B

B-LINE

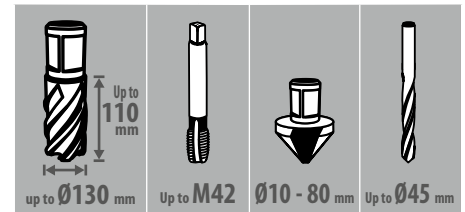

RB 130 B

Core drill dimensions	Ø 12.0 - 130.0 mm / Ø 20.0 - 50.0 mm (cutting depth 110 mm)
Cutting depth	50.0 mm / 110.0 mm
Twist drill	Up to Ø 45.0 mm with MT4 DIN 345 direct
Counterboring	Ø 10.0 - 80.0 mm
Tapping	with tapping attachment Up to M42
Arbors	MT4
Stroke	230 mm
Height adjustment	100 mm
4-speed gearbox	1. Step 30 - 80 rpm 2. Step 50 - 120 rpm 3. Step 130 - 350 rpm 4. Step 210 - 550 rpm
Power consumption	2,500 W
Voltage	230 V 50/60 Hz 110 V 50/60 Hz
Magnetic adhesion strength	33,000 N
Tool force (10 mm)	5,000 N
Magnetic base	90 x 400 mm
Weight	37.0 kg

Motor	
Smooth start	✓
Oil bath gearbox	✓
Mech. Slip clutch	✓
Operation	
Soft-touch grips	✓
Ergonomic switch keyboard	✓
Magnet	
Metal rings	✓

Scope of delivery	
<ul style="list-style-type: none"> • Metal core drilling machine RB 130 • Coolant device • Reduction sleeve MT4/3 • Transportation packing • Drill spray • Chip hook • Seat belt • Operating instructions 	



VIDEO

ALFRA Rotabest® RB 130 B

230 Volt

Prod.-No.

18646

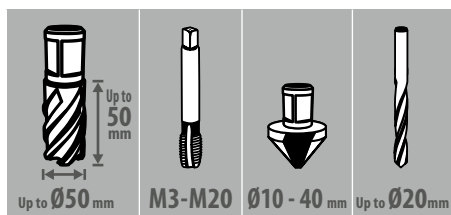

RB 50 B RL-E

Core drill dimensions	Ø 12.0 - 50.0 mm
Cutting depth	50.0 mm
Twist drill	Ø 1.0 to 16.0 mm with quick-release chuck MT2 up to Ø 20.0 mm with MT 2 DIN 345 direct
Counterboring	Ø 10.0 - 40.0 mm
Tapping	with tapping chucks: M3 - M14 with tapping attachment M3 - M20
Arbors	MT2
Stroke	170 mm
Height adjustment	100 mm
2-speed gearbox	right / left 1. Step 100 - 250 rpm 2. Step 180 - 450 rpm
Power consumption	1,200 W
Voltage	230 V 50/60 Hz 110 V 50/60 Hz
Magnetic adhesion strength	16,000 N
Tool force (10 mm)	3,800 N
Magnetic base	92 x 238 mm
Weight	16.0 kg

Motor	
Right/left run	✓
Oil bath gearbox	✓
Slides	
Infinitely adjustable	✓
Operation	
Soft-touch grips	✓
Ergonomic switch keyboard	✓
Magnet	
Metal rings	✓

Scope of delivery	
<ul style="list-style-type: none"> • Metal core drilling machine RB 50 B RL-E • Coolant device • MT2 tool holder with internal cooling • Quick-release chuck for twist drills • Carrying case • Drill spray • Chip hook • Seat belt • Operating Instructions • incl. 1 core drill free 	



Prod.-No.

ALFRA Rotabest® RB 50 B RL-E 230 Volt

18612

ALFRA Rotabest® RB 50 B RL-E 110 Volt

18612.110

ALFRA ROTABEST® – RB 80 B RL-E

RL-E-LINE

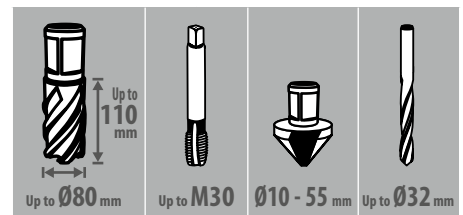

RB 80 B RL-E

Core drill dimensions	Ø 12.0 - 80.0 mm / Ø 20.0 - 50.0 mm (cutting depth 110 mm)
Cutting depth	50.0 mm / 110.0 mm
Twist drill	Ø 1.0 - 16.0 mm with drill chuck Up to Ø 32.0 mm with MT ₃ DIN 345
Counterboring	Ø 10 - 55.0 mm
Tapping	with tapping chucks: Up to M30 with tapping attachment: Up to M30
Arbors	MT ₃
Stroke	190 mm
Height adjustment	60 mm
4-speed gearbox	right / left 1. Step 50 - 110 rpm 2. Step 75 - 175 rpm 3. Step 105 - 245 rpm 4. Step 165 - 385 rpm
Power consumption	1,800 W
Voltage	230 V 50/60 Hz 110 V 50/60 Hz
Magnetic adhesion strength	20,000 N
Tool force (10 mm)	4,200 N
Magnetic base	92 x 238 mm, 30° adjustable right and left, 10 mm front and back
Weight	22.0 kg

Motor	
Right/left run	✓
Oil bath gearbox	✓
Mech. Slip clutch	✓
Slides	
Infinitely adjustable	✓
Operation	
Soft-touch grips	✓
Ergonomic switch keyboard	✓
Magnet	
Metal rings	✓

Scope of delivery	
<ul style="list-style-type: none"> • Metal core drilling machine RB 80 B RL-E • Coolant device • MT₃ tool holder with internal cooling • Quick-release chuck for twist drills • Carrying case • Drill spray • Chip hook • Seat belt • Operating Instructions • incl. 1 core drill free 	

Prod.-No.

ALFRA Rotabest® RB 80 B RL-E	230 Volt	18629
ALFRA Rotabest® RB 80 B RL-E	110 Volt	18629.110

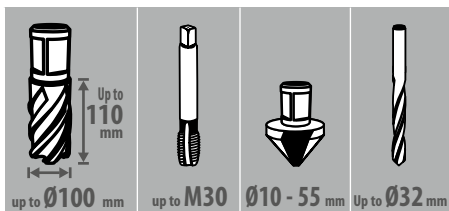

RB 100 B RL-E

Core drill dimensions	Ø 12.0 - 100.0 mm / Ø 20.0 - 50.0 mm (cutting depth 110 mm)
Cutting depth	50.0 mm / 110.0 mm
Twist drill	Ø 1.0 - 16.0 mm with drill chuck Up to Ø 32.0 mm with MT3 DIN 345
Counterboring	Ø 10.0 - 55.0 mm
Tapping	with tapping chucks: Up to M30 with tapping attachment: Up to M30
Arbors	MT3
Stroke	245 mm
Height adjustment	116 mm
4-speed gearbox	right / left
	1. Step 50 - 150 rpm
	2. Step 75 - 230 rpm
	3. Step 100 - 310 rpm 4. Step 160 - 490 rpm
Power consumption	2,500 W (230 V) 2,400 W (110 V)
Voltage	230 V 50/60 Hz 110 V 50/60 Hz
Magnetic adhesion strength	20,000 N
Tool force (10 mm)	4,000 N
Magnetic base	92 x 238 mm, 30° adjustable right and left, 10 mm front and back
Weight	28.0 kg

Motor	
Right/left run	✓
Full-wave control electronics	✓
Smooth start	✓
Overload protection	✓
Oil bath gearbox	✓
Mech. Slip clutch	✓
Slides	
Infinitely adjustable	✓
Operation	
Soft-touch grips	✓
Ergonomic switch keyboard	✓
Magnet	
Metal rings	✓

Scope of delivery	
<ul style="list-style-type: none"> • Metal core drilling machine RB 100 B RL-E • Coolant device • MT3 tool holder with internal cooling • Carrying case • Chip hook • Seat belt • Drill spray • incl. 1 core drill free 	



Prod.-No.

ALFRA Rotabest® RB 100 B RL-E	230 Volt	18636
ALFRA Rotabest® RB 100 B RL-E	110 Volt	18636.110

ALFRA ROTABEST® – RB 130 B RL-E

RL-E-LINE

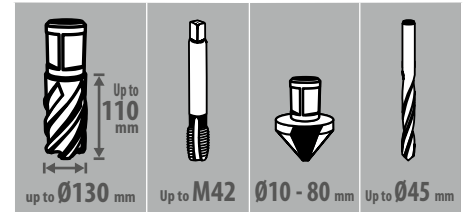

RB 130 B RL-E

Core drill dimensions	Ø 12.0 - 130.0 mm / Ø 20.0 - 50.0 mm (cutting depth 110 mm)
Cutting depth	50.0 mm / 110.0 mm
Twist drill	Up to Ø 45.0 mm with MT4 DIN 345 direct
Counterboring	Ø 10.0 - 80.0 mm
Tapping	with tapping attachment Up to M42
Arbors	MT4
Stroke	230 mm
Height adjustment	100 mm
4-speed gearbox	right / left 1. Step 30 - 80 rpm 2. Step 50 - 120 rpm 3. Step 130 - 350 rpm 4. Step 210 - 550 rpm
Power consumption	2,500 W
Voltage	230 V 50/60 Hz 110 V 50/60 Hz
Magnetic adhesion strength	33,000 N
Tool force (10 mm)	5,000 N
Magnetic base	90 x 400 mm
Weight	37.0 kg

Motor

Right/left run	✓
Smooth start	✓
Oil bath gearbox	✓
Mech. Slip clutch	✓

Operation

Soft-touch grips	✓
Ergonomic switch keyboard	✓

Magnet

Metal rings	✓
--------------------	---

Scope of delivery

- Metal core drilling machine RB 130 B RL-E
- Coolant device
- Reduction sleeve MT4/3
- Transportation packing
- Drill spray
- Chip hook
- Seat belt
- Operating instructions

Prod.-No.

ALFRA Rotabest® RB 130 B RL-E	230 Volt	18647
ALFRA Rotabest® RB 130 B RL-E	110 Volt	18647.110



RUTABEST
35 SP
MADE IN ITALY



▶ VIDEO

ALFRA ROTABEST® – RB 35 SP

SP-LINE



MADE IN GERMANY

Can be used with a permanent magnet from 3 mm material thickness

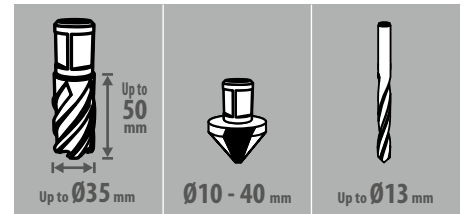

RB 35 SP

Core drill dimensions	Ø 12.0 - 35.0 mm
Cutting depth	50.0 mm
Twist drill	Ø 1.0 - 13.0 mm
Counterboring	Ø 10.0 - 40.0 mm
Arbors	Quick-release chuck
Stroke	105 mm
Height adjustment	80 mm
Gearbox - on-load speed	450 rpm
Power consumption	1,100 W
Voltage	230 V 50/60 Hz 110 V 50/60 Hz
Tool Force (10 mm) / Magnetic adhesion force	2,800 N/17,000 N
Tool force (6 mm S235)	2,300 N
Magnetic base	72 x 190 mm
Weight	9.9 kg

Motor	
Smooth start	✓
Hybrid relay	✓
Overload protection	✓
Motor emergency stop	✓
Slide	
Infinitely adjustable	✓
Self-adjusting guide	✓
Operation	
Soft-touch grips	✓
Membrane keyboard	✓
Holder for Allen key	✓
Cable length 5 m	✓
Magnet	
Sensor/LED	✓
Metal rings	✓
Performance and weight optimisation	✓

Scope of delivery	
<ul style="list-style-type: none"> • Metal core drilling machine RB 35 SP with quick-release chuck • Carrying case • Seat belt • Coolant device • Operating Instructions • incl. 1 core drill free 	

Prod.-No.

ALFRA Rotabest® RB 35 SP	230 Volt	18801
ALFRA Rotabest® RB 35 SP	110 Volt	18801.110

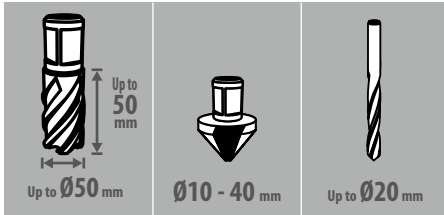

RB 50 SP

Core drill dimensions	Ø 12.0 - 50.0 mm
Cutting depth	50.0 mm
Twist drill	Ø 1.0 - 20.0 mm
Counterboring	Ø 10.0 - 40.0 mm
Arbors	MT2
Stroke	100 mm
Height adjustment	47 mm
Gearbox - on-load speed	1. Step 250 rpm 2. Step 450 rpm
Power consumption	1,200 W
Voltage	230 V 50/60 Hz 110 V 50/60 Hz
Tool Force (10 mm) / Magnetic adhesion force	2,800 N/17,000 N
Tool force (6 mm S235)	2,000 N
Magnetic base	72 x 190 mm
Weight	11.5 kg

Motor	
Smooth start	✓
Hybrid relay	✓
Overload protection	✓
Motor emergency stop	✓
Oil bath gearbox	✓
Slide	
Infinitely adjustable	✓
Self-adjusting guide	✓
Operation	
Soft-touch grips	✓
Membrane keyboard	✓
Holder for Allen key	✓
Cable length 5 m	✓
Magnet	
Sensor/LED	✓
TiN-coating	✓
Performance and weight optimisation	✓

Scope of delivery

- Metal core drilling machine RB 50 SP
- Tool holder MT 2 with quick-release chuck, including internal cooling
- Carrying case
- Seat belt
- Coolant device
- Operating Instructions
- **incl. 1 core drill free**



MADE IN GERMANY



Can be used with a permanent magnet from 3 mm material thickness



▶ VIDEO



Prod.-No.

ALFRA Rotabest® RB 50 SP 230 Volt

18851

ALFRA Rotabest® RB 50 SP 110 Volt

18851.110

ALFRA ROTABEST® – V 40

V-LINE



Ø10 - 32 mm

V 40

Core drill dimensions	Ø 12.0 - 40.0 mm
Cutting depth	30.0 mm
Counterboring	Ø 10.0 - 32.0 mm
Arbors	19 mm Weldon shank
1-speed gearbox	450 rpm
Stroke	45 mm
Power consumption	900 W
Voltage	230 V 50/60 Hz 110 V 50/60 Hz
Magnetic adhesion strength	16,000 N
Tool force (10 mm)	2,100 N
Magnetic base	95 x 200 mm
Weight	12.5 kg

Motor	
Compact, lying	
Compact mitre gear	
Slide	
2-sided column guide	
Operation	
Space-saving - through ratchet	
Magnet	
Metal rings	✓
Performance and weight optimisation	✓

Scope of delivery	
<ul style="list-style-type: none"> • Metal core drilling machine V 40 • Coolant pressure bottle • Carrying case • Allen key for Weldon arbor • Seat belt • Ejector pin 6.35 x 74 mm (specially for Rotabest® V 40) • Operating instructions • incl. 1 core drill free 	



Prod.-No.

ALFRA Rotabest® V 40	230 Volt	18712
ALFRA Rotabest® V 40	110 Volt	18712.110

“The Alfa SPV is a real asset. In addition to the precision made possible by its use, the drill stand also brings a considerable gain in safety for the user, because jerking and jamming machines are now a thing of the past...Thanks to permanent magnets, a secure hold of the SPV is guaranteed for many years without follow-up costs.”

Jörg Ueltkesforth

Technical editor, Motor & Maschine
3/2018



PDF

Already from 3 mm
material thickness



ALFRA – UNIVERSAL- MAGNETIC DRILL STAND SP-V

V-LINE

Through variable mountings, different drilling machines can be used. Even cordless drill machines can be used as a cordless combination with the permanent magnetic stand for a virtually unlimited range of applications – from 3 mm thickness!



Can be used with a permanent magnet from 3 mm material thickness

MADE IN GERMANY
US Patent No. 8350663B1



SP-V	
Twist drill	Ø depending on the used drill
Arbor	Ø 43 mm Euro Neck, Ø 48.6 mm Ø 61.7 mm
Stroke	105 mm
Height adjustment	80 mm
Magnetic adhesion force	17,000 N
Tool-Force (10 mm S235)	2,800 N
Tool force (6 mm S235)	2,300 N
Magnetic base	72 x 190 mm
Weight	6.8 kg
Magnet	
TiN-coating	✓
Performance and weight optimisation	✓
Scope of delivery	
<ul style="list-style-type: none"> • Universal Magnetic Drill Stand SP-V • Carrying case • Operating instructions 	





ALFRA universal magnetic drill stand SP-V

Prod.-No.

18343

ACCESSORIES – ARBORS

Description	Prod.-No.	RB 35 B RB 35/50 B Piccolo	RB 50 B RB 50 B RL-E RB 50 SP	RB 80 B RB 80 B RL-E	RB 100 B RL-E	RB 130 B RB 130 B RL-E	Figure
Quick-release tool holder Rota-Quick® • Morse taper 2 • with automatic internal cooling • suitable for all machines with drill spindle MT 2 • Application range to 40 mm core drill Ø	18650	-	✓	-	-	-	
Quick-release tool holder Rota-Quick® • Morse taper 3 • with automatic internal cooling • suitable for all machines with drill spindle MT 3 • Application range to 40 mm core drill Ø	18651	-	-	✓	✓	-	
Quick-release chuck with Weldon arbor for twist drills • Ø 1-13 mm	18107	✓	-	-	-	-	
Quick-release chuck with Morse taper 2 for twist drills • Ø 1-16 mm	18008	-	✓	-	-	-	
Quick-release chuck with Morse taper 3 for twist drills • Ø 1-16 mm	18009	-	-	✓	✓	-	
Tool holder AMT-2 - Morse taper 2 for core drills • with Weldon shank • Ø 12 - 60 mm • with automatic internal cooling • suitable for all machines with drill spindle MT 2	18003	-	✓	-	-	-	
Tool holder AMT-2 - extended version • with Weldon shank • Ø 12-50 mm, cutting depth 110 mm • with automatic internal cooling • suitable for all machines with drill spindle MT 2	18003L	-	✓	-	-	-	
Tool holder AMT-2 without internal cooling	18001	-	✓	-	-	-	
Adapter sleeve MT 3/2	18023	-	-	✓	✓	-	
Adapter sleeve MT 4/3	18027	-	-	-	-	combined with 18002 & 18025 & 18025 L	
Tool holder AMT-3 without internal cooling	18002	-	-	✓	✓	-	
Tool holder AMT-3 - Morse taper 3 for core drills • with Weldon shank • Ø 12 - 60 mm • with automatic internal cooling • suitable for all machines with drill spindle MT 3	18025	-	-	✓	✓	-	
Tool holder AMT-3 - extended version • with Weldon shank • Ø 12-50 mm, cutting depth 110 mm • with automatic internal cooling • suitable for all machines with drill spindle MT 3	18025L	-	-	✓	✓	-	
Tool holder AL3 - Morse taper 3 • for core drills heavy duty version • Ø 51-100 mm with keyway with automatic internal cooling	20230	-	-	✓	✓	-	
Tool holder AL 4 - Morse taper 4 • for core drills heavy duty version • Ø 51-100 mm with keyway with automatic internal cooling • with Ejector pin • suitable for RB 130 B	20240	-	-	-	-	✓	

ACCESSORIES – ADAPTERS

Description	Prod.-No.	Figure
<p>Adapter with female thread M18 x 6 p 1.5 Adapter for use on Rotabest® HSS-Co Eco and HSS-Co RQX core drills of Ø 12.0 mm to 32.0 mm and Rotabest® carbide core drills of Ø 14.0-32.0 mm on: FEIN core drilling machines of the type KBM 542</p>	20201	 <p>Weldon</p> <p>FEIN/Hitachi M18 x 6P 1.5 Internal thread</p>
<p>Adapter with external thread (including ejector pin) Adapter for use of FEIN core drills with internal thread M18 x 6 p 1.5 on metal core drill machines with Weldon shank.</p>	20202	 <p>FEIN/Hitachi M18 x 6P 1.5 Internal thread</p> <p>Weldon</p>
<p>Ejector pin suitable for Prod.-No. 20202 - single</p>	20203	
<p>Adapters Adapter for use of all core drills with a Weldon shank on FEIN Quick IN quick-release system. This adapter is eliminated when you use our HSS-Eco core drill of series Prod.-No. 1909... and 2009...</p>	20204	 <p>FEIN-QuickIN</p>
<p>Adapter Adapter for use of all core drills with a Weldon shank on ALFRA-Rota-Quick® und Nitto quick-release systems. (incl. 2 Ejector pins Prod.-No. 1950500 and 1975500 + Allen key)</p>	20205	 <p>Weldon</p> <p>ALFRA-Rota-Quick® and Nitto</p>
<p>Ejector pin for HSS core drills cutting depth 30 mm, also suitable for adapter Prod.-No. 20204 among others</p>	1926500	
<p>Ejector pin for HSS core drills cutting depth 50 mm, also suitable for adapter Prod.-No. 20204 among others</p>	1950500	
<p>Extension adapter With Weldon shank and ejector pin. For use on core drills 25 - 30 – 35 – 50 mm cutting depth in cases when the surface of the material to be drilled is deeper than the stand space of the machine. The first ejector pin triggers the second ejector pin; the coolant flows through the borehole to the core drill. Total length adapters: 80 mm Diameter: 30 mm Ejector pin: 6.35 x 77 mm Prod.-No. 1926500</p>	20206	
<p>Adapter complete with ejector pin + Allen key Adapter for use on core drills with FINE-Quick IN shaft on metal core drill machines with Weldon arbor.</p>	20210	 <p>FEIN-QuickIN</p> <p>Weldon</p>
<p>Replacement ejector pin (only for adapters) 6.35 x 125 mm</p>	1936501	
<p>Adapter for carbide hole saws, e.g. type MBS on metal core drill machines with Weldon arbor (incl. ejector pin Prod.-No. 1950500)</p>	060WD	

ACCESSORIES – COOLANT

Description	Prod.-No.	Figure
Coolant system for RB 40 RL-E, RB 60 RL-E, RB 100 B RL-E, RB 130, suitable for tool holder with internal cooling AMT-2 (Prod.-No. 18003) and AMT-3 (Prod.-No. 18025)	18104	
Coolant system for RB 35 B	189311241	
Coolant system for RB 35/50 X Piccolo, RB 35 SP, RB 50 SP, RB 35/50 B Piccolo, RB 50 B, RB 50 X, 80 X, 80 SP and 80 SP RL-E, suitable for tool holder with internal cooling AMT-2 (Prod.-No. 18003) and AMT-3 (Prod.-No. 18025)	189412029	
Coolant system for RB V 32 and RB V 40	18106	
ALFRA 2000 Cutting and drilling spray 250 ml can	21010	
ALFRA 4000 High performance cutting oil spray 300 ml can	21040	

ACCESSORIES – TAPPING

Description	Shaft	Prod.-No.	All models with MT2 arbor	All models with MT3 arbor	
Tapping attachment M3 - M12 Scope of delivery: with Rota-Quick® and MT2, interchangeable, Plastic case, manual	MT2 + RotaQuick®	18652	✓	With reduction sleeve MT 3/2	
Tapping attachment M10 - M20 Scope of delivery: with Rota-Quick® and MT2, interchangeable, Plastic case, manual	MT2 + RotaQuick®	18653	✓	With adapter sleeve MT 3/2	
Reduction sleeve for tapping attachment – from MT3 to MT2		18023			
Tapping quick-release chuck size 1 MT2, single, suitable for RB 50 B RL-E		18661			
Tapping quick-release chuck size 2 MT 3, single, suitable for RB 80 B RL-E and RB 100 B RL-E		18681			 <i>Prod.-No. 18681 - Installation instructions</i>

Quick change inserts with clutch

		Shank-Ø	Square	Tap drill	Prod.-No.
Size 1	M3	3.5	2.7	DIN 371	18662
Size 1	M4	4.5	3.4	DIN 371	18663
Size 1	M5	6.0	4.9	DIN 371	18664
Size 1	M6	6.0	4.9	DIN 371	18678
Size 1	M8	8.0	6.2	DIN 371	18665
Size 1	M10	10.0	8.0	DIN 371	18666
Size 1	M12	9.0	7.0	DIN 376	18667
Size 1	M14	11.0	9.0	DIN 376	18668
Size 2	M6	6.0	4.9	DIN 371	18682
Size 2	M8	8.0	6.2	DIN 371	18683
Size 2	M10	10.0	8.0	DIN 371	18684
Size 2	M12	9.0	7.0	DIN 376	18685
Size 2	M14	11.0	9.0	DIN 376	18686
Size 2	M16	12.0	9.0	DIN 376	18687
Size 2	M18	14.0	11.0	DIN 376	18688
Size 2	M20	16.0	12.0	DIN 376	18689
Size 2	M22	18.0	14.5	DIN 376	18690



ALFRA – MAGNETIC CHIP REMOVER

In a stainless steel round rod, you can move a magnet back and forth. The strong magnet attracts the metal chips – pull knob, chips fall out. For more cleanliness in the workplace.

Prod.-No.
18654

ALFRA magnetic chip remover, length 400 mm



Prod.-No. 18654



ALFRA – CHIP BRUSH

- 1 Adjustable telescopic handle
- 2 Up to 9 kg load capacity



- For practical cleaning of floors in various work areas
- Load capacity up to 9 kg
- Easy removal of picked up metal parts by simple release mechanism on a rod
- Sweeping with 400 mm
- 750-1500 mm adjustable telescopic handle



Prod.-No.
18655

ALFRA chip brush

ROTABEST® – VACUUM SYSTEM VACUBEST

Use on **non-magnetic** surfaces such as copper, aluminium, brass, stainless steel, plastics and textured subsurface (e.g. corrugated and chequer plate)

Suction capacity: 1.5 m³/h – 25l/min
Max. vacuum mbar (abs.): 200
Overpressure mbar: 300
Dimensions suction plate: 400 x 200 mm

Scope of delivery:

Pump (230 V, 50 Hz), vacuum plate, 3 mtr. suction pipe

Description

Vacuum system Vacubest

Prod.-No.

18150



Pump

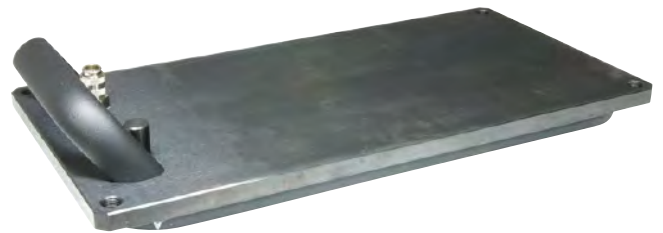

Vacuum plate

TIP:

Name your application problem – we will be happy to advise you.

ALFRA ROTABEST® HSS CORE DRILLS

GRINDED SHARP – ALFRA HSS CORE DRILLS LOVE HEAVY METAL

Core drill against metal – a daily challenge on construction sites or in metal construction. ROTABEST® core drills are made of high tensile tool steel. Due to the model they ensure accurate holes with diameters from 12 mm up to 60 mm – with a cutting depth from 30 mm to 110 mm.



1 Product features
e.g. pre- and post-cutter

2 Product number

3 Quality
■ HSS-Co RQX
■ HSS-Co ECO
■ HSS-Basic

4 Diameter

5 Cutting depth

6 Arbor typ
■ WELDON
■ FEIN QUICK-IN

More than just a shell
 The high quality products belonging to our HSS-core-drill-family deserve a package, which is offering more than protection from environmental influences. On the label you find all important informations about our core drills at a glance.

Thought-out packages with extra information:
 Our core drills are easy on the eye. That's why the sturdy package is offering you a look at the content. Special characteristics of the plastic case: It's transparent, informative and a guarantor regarding quality assurance.

Your advantage:

- The potential buyers are not tempted to open the package any more.
- For this reason the risk for contamination is diminishing. Furthermore the drills are not going to be damaged by drying-out.
- The label also serves as a sealing, guaranteeing original packaging when it's intact.
- Due to the Alfra-colour code, your customers can see at a glance, which type of the HSS CORE DRILL is inside the package.

DOWN-TO-EARTH INDIVIDUALISTS – ALFRA ROTABEST® CORE DRILLS

Within the ROTABEST core drill family everyone has their own strengths – but still the same roots: Passion for Tools, made by Alfra.

WELDON
HSS-BASIC



The solid one: ALFRA ROTABEST® HSS-BASIC Core drill WELDON
 Reliable, robust, accurate – our ROTABEST® basis model is convincing with a solid performance at a small price.

- With Weldon shank 19.0 mm, 2 driving surfaces
- Internal bore 6.35 mm
- Steel quality: Special super high speed steel
- Polished section: with pre- and post-cutter

WELDON

HSS-CO-ECO



The all-purpose-weapon: ALFRA ROTABEST® HSS-CO-ECO Core drill WELDON
The ROTABEST ECO-models are genuine golden boys – not only from a visual viewpoint. Due to the Weldon shank they are perfect partners for all core drilling machines with a weldon toolholder. Another advantage is the long service life

- With Weldon shank 19.0 mm, 2 driving surfaces
- Internal bore: 6.35 mm
- Steel quality: Special super high speed steel
- Polished section: with pre- and post-cutter

FEIN-QUICKIN

HSS-CO-ECO



The compatible one : ALFRA ROTABEST® HSS-CO-ECO Core drill FEIN-QUICKIN
For those, who doesn't like renouncing:
You are working with a Fein-metal core drilling device with QuickIn tool holder? Due to the ROTABEST ECO-models with FEIN-QUICKIN shank you can rely on proven Alfra-quality.

- Suitable for FEIN magnetic drilling machines with Quick-IN arbor.
- Special shank, 18.0 mm with 4 bearing recesses
- Internal hole 6.4 mm
- Steel quality: Special super high speed steel

WELDON

HSS-CO-RQX



The endurance runner: ALFRA ROTABEST® HSS-CO-RQX Core drill WELDON
When it's getting hot: The specially coated RQX Models are providing full performance even when the temperature is rising up to 1000 ° C. For example when it comes to long lasting drilling processes or horizontal drilling without coolant.

- With Weldon shank 19.0 mm, 2 driving surfaces
- Internal bore 6.35 mm
- Steel quality: Special super high speed steel, coated
- Polished section: with pre- and post-cutter



The solid one:

ALFRA ROTABEST® HSS-BASIC Core drill WELDON

- With Weldon shank 19.0 mm, 2 driving surfaces
- Internal bore 6.35 mm
- Steel quality: Special super high speed steel
- Polished section: with pre- and post-cutter

Suitable on:

ALFRA Rotabest®, BDS, Bux, Ruko, Magnetor, Euroboor, Universal, Nitto, Jancy, Hougen, Magtron, Promac, Rotabroach and all other magnetic drills with Weldon shank.

Ø in mm	Cutting depth	
	30 mm Prod.-No.	50 mm Prod.-No.
12.0	1907012025	1907012050
13.0	1907013025	1907013050
13.5	1907013525	1907013550
14.0	1907014025	1907014050
15.0	1907015025	1907015050
15.5	1907015525	1907015550
16.0	1907016025	1907016050
17.0	1907017025	1907017050
17.5	1907017525	1907017550
18.0	1907018025	1907018050
19.0	1907019025	1907019050
19.5	1907019525	-
20.0	1907020025	1907020050
21.0	1907021025	1907021050
22.0	1907022025	1907022050
23.0	1907023025	1907023050
24.0	1907024025	1907024050
25.0	1907025025	1907025050
26.0	1907026025	1907026050
26.5	1907026525	1907026550
27.0	1907027025	1907027050
28.0	1907028025	1907028050
29.0	1907029025	1907029050
30.0	1907030025	1907030050
31.0	1907031025	1907031050
32.0	1907032025	1907032050
33.0	1907033025	1907033050
34.0	1907034025	1907034050
35.0	1907035025	1907035050
36.0	1907036025	1907036050
37.0	1907037025	1907037050
38.0	1907038025	1907038050
39.0	1907039025	1907039050
40.0	1907040025	1907040050

Ø in mm	Cutting depth	
	30 mm Prod.-No.	50 mm Prod.-No.
41.0	1907041025	1907041050
42.0	1907042025	1907042050
43.0	1907043025	1907043050
44.0	1907044025	1907044050
45.0	1907045025	1907045050
46.0	1907046025	1907046050
47.0	1907047025	1907047050
48.0	1907048025	1907048050
49.0	1907049025	1907049050
50.0	1907050025	1907050050
51.0	-	1907051050
52.0	1907052025	1907052050
53.0	-	1907053050
54.0	-	1907054050
55.0	1907055025	1907055050
56.0	-	1907056050
57.0	-	1907057050
58.0	-	1907058050
59.0	-	1907059050
60.0	1907060025	1907060050
Ejector pin	1926500	1950500
Dimension	6.35 x 77 mm	6.35 x 102 mm



Weldon

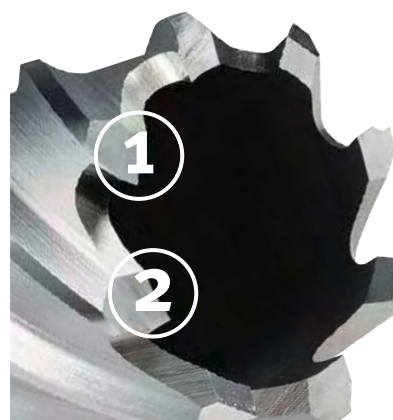

Heavy duty serration with pre- (1) and post-cutter (2)

ALFRA ROTABEST® HSS-BASIC Core drill WELDON Sets



- A range of the most commonly used core drills clearly arranged in a sturdy plastic case.
- Absolute protection of the teeth tips in the rough usage operation at installation and in the workshop.
- On request, we can assemble individual sets in 12.0 to 30.0 mm diameters.

Ø mm	12.0	14.0	16.0	18.0	20.0	22.0	24.0	26.0
Cutting depth 30 mm								
Prod.-No.								
1907125	3 pc. ALFRA ROTABEST® HSS-BASIC Core drill WELDON set: incl. 1 ejector pin Prod.-No. 1926500							
		●		●		●		
1907003025	6 pc. ALFRA ROTABEST® HSS-BASIC Core drill WELDON set: incl. 1 ejector pin Prod.-No. 1926500							
	●	●	●	●	●	●		
1907001025	10 pc. ALFRA ROTABEST® HSS-BASIC Core drill WELDON set: incl. 2 ejector pins Prod.-No. 1926500							
	●●	●●	●	●●	●	●●		
Cutting depth 50 mm								
1907003050	6 pc. ALFRA ROTABEST® HSS-BASIC Core drill WELDON set: incl. 1 ejector pin Prod.-No. 1950500							
		●	●	●	●	●		●
1907001050	10 pc. ALFRA ROTABEST® HSS-BASIC Core drill WELDON set: incl. 2 ejector pins Prod.-No. 1950500							
		●●	●	●●	●	●●	●	●



The all-purpose-weapon:

ALFRA ROTABEST® HSS-CO-ECO Core drill WELDON

- With Weldon shank 19.0 mm, 2 driving surfaces
- Internal bore: 6.35 mm
- Steel quality: Special super high speed steel
- Polished section: with pre- and post-cutter

Suitable on:

ALFRA Rotabest®, BDS, Bux, Ruko, Magnetor, Euroboor, Universal, Nitto, Jancy, Hougen, Magtron, Promac, Rotabroach and all other magnetic drills with Weldon shank.

Cutting depth

Ø in mm	Cutting depth	
	30 mm Prod.-No.	50 mm Prod.-No.
12.0	1901012025	1901012050
13.0	1901013025	1901013050
13.5	1901013525	1901013550
14.0	1901014025	1901014050
15.0	1901015025	1901015050
15.5	1901015525	1901015550
16.0	1901016025	1901016050
17.0	1901017025	1901017050
17.5	1901017525	1901017550
18.0	1901018025	1901018050
19.0	1901019025	1901019050
19.5	1901019525	1901019550
20.0	1901020025	1901020050
21.0	1901021025	1901021050
22.0	1901022025	1901022050
23.0	1901023025	1901023050
24.0	1901024025	1901024050
25.0	1901025025	1901025050
26.0	1901026025	1901026050
26.5	1901026525	1901026550
27.0	1901027025	1901027050
28.0	1901028025	1901028050
29.0	1901029025	1901029050
30.0	1901030025	1901030050
31.0	1901031025	1901031050
32.0	1901032025	1901032050
33.0	1901033025	1901033050
34.0	1901034025	1901034050
35.0	1901035025	1901035050
36.0	1901036025	1901036050
37.0	1901037025	1901037050
38.0	1901038025	1901038050
39.0	1901039025	1901039050
40.0	1901040025	1901040050
41.0	1901041025	1901041050
42.0	1901042025	1901042050
43.0	1901043025	1901043050
44.0	1901044025	1901044050
45.0	1901045025	1901045050
46.0	1901046025	1901046050
47.0	1901047025	1901047050
48.0	1901048025	1901048050
49.0	1901049025	1901049050
50.0	1901050025	1901050050
51.0	-	1901051050
52.0	1901052025	1901052050
53.0	-	1901053050
54.0	-	1901054050
55.0	1901055025	1901055050
56.0	-	1901056050
57.0	-	1901057050
58.0	-	1901058050
59.0	-	1901059050
60.0	1901060025	1901060050

Cutting depth

Ø in mm	Cutting depth
	110 mm Prod.-No.*
20.0	1901020110
22.0	1901022110
24.0	1901024110
25.0	1901025110
26.0	1901026110
28.0	1901028110
30.0	1901030110
32.0	1901032110
35.0	1901035110
40.0	1901040110
45.0	1901045110
50.0	1901050110

* Caution: HSS-Co Eco core drill cutting depth 110 mm can only be used with tool holder AMT 2 L (Prod.-No. 18003 L) or AMT 3 L (Prod.-No. 18025 L).



Weldon

Ejector pin at cutting depth

30 mm Prod.-No.	50 mm Prod.-No.	110 mm Prod.-No.*
1926500 (6.35 x 77 mm)	1950500 (6.35 x 102 mm)	2001502 (6.35 x 160 mm)



Heavy duty serration with pre- (1) and post-cutter (2)

ALFRA ROTABEST® HSS-CO-ECO CORE DRILL WELDON Sets



- A range of the most commonly used core drills clearly arranged in a sturdy plastic case.
- Absolute protection of the teeth tips in the rough usage operation at installation and in the workshop.
- On request, we can assemble individual sets in 12.0 to 30.0 mm diameters.

Ø mm	12.0	14.0	16.0	18.0	20.0	22.0	24.0	26.0
Cutting depth 30 mm								
Prod.-No.								
1901125	3 pc. ALFRA ROTABEST® HSS-CO-ECO Core drill WELDON set: incl. 1 ejector pin Prod.-No. 1926500							
		●		●		●		
1901003025	6 pc. ALFRA ROTABEST® HSS-CO-ECO Core drill WELDON set: incl. 1 ejector pin Prod.-No. 1926500							
	●	●	●	●	●	●		
1901001025	10 pc. ALFRA ROTABEST® HSS-CO-ECO Core drill WELDON set: incl. 2 ejector pins Prod.-No. 1926500							
	●●	●●	●	●●	●	●●		
Cutting depth 50 mm								
1901003050	6 pc. ALFRA ROTABEST® HSS-CO-ECO Core drill WELDON set: incl. 1 ejector pin Prod.-No. 1950500							
		●	●	●	●	●		●
1901001050	10 pc. ALFRA ROTABEST® HSS-CO-ECO Core drill WELDON set: incl. 2 ejector pins Prod.-No. 1950500							
		●●	●	●●	●	●●	●	●



The endurance runner:

ALFRA ROTABEST® HSS-CO-RQX Core drill WELDON

- With Weldon shank 19.0 mm, 2 driving surfaces
- Internal bore 6.35 mm
- Steel quality: Special super high speed steel, coated
- polished section: with pre- and post-cutter

Suitable on:

ALFRA Rotabest®, BDS, Bux, Ruko, Magnetor, Euroboor, Universal, Nitto, Jancy, Hougen, Magtron, Promac, Rotabroach and all other magnetic drills with Weldon shank.

Cutting depth 30 mm

Cutting depth 50 mm

Ø in mm	Prod.-No.
12.0	1902012025
13.0	1902013025
14.0	1902014025
15.0	1902015025
16.0	1902016025
17.0	1902017025
18.0	1902018025
19.0	1902019025
20.0	1902020025
21.0	1902021025
22.0	1902022025
23.0	1902023025
24.0	1902024025
25.0	1902025025
26.0	1902026025
27.0	1902027025
28.0	1902028025
29.0	1902029025
30.0	1902030025
31.0	1902031025
32.0	1902032025
33.0	1902033025
34.0	1902034025
35.0	1902035025
36.0	1902036025
37.0	1902037025
38.0	1902038025
39.0	1902039025
40.0	1902040025
41.0	1902041025
42.0	1902042025
43.0	1902043025
44.0	1902044025
45.0	1902045025
46.0	1902046025
47.0	1902047025
48.0	1902048025
49.0	1902049025
50.0	1902050025
51.0	-
52.0	-
53.0	-
54.0	-
55.0	-
56.0	-
57.0	-
58.0	-
59.0	-
60.0	-

Ø in mm	Prod.-No.
12.0	1902012050
13.0	1902013050
14.0	1902014050
15.0	1902015050
16.0	1902016050
17.0	1902017050
18.0	1902018050
19.0	1902019050
20.0	1902020050
21.0	1902021050
22.0	1902022050
23.0	1902023050
24.0	1902024050
25.0	1902025050
26.0	1902026050
27.0	1902027050
28.0	1902028050
29.0	1902029050
30.0	1902030050
31.0	1902031050
32.0	1902032050
33.0	1902033050
34.0	1902034050
35.0	1902035050
36.0	1902036050
37.0	1902037050
38.0	1902038050
39.0	1902039050
40.0	1902040050
41.0	1902041050
42.0	1902042050
43.0	1902043050
44.0	1902044050
45.0	1902045050
46.0	1902046050
47.0	1902047050
48.0	1902048050
49.0	1902049050
50.0	1902050050
51.0	1902051050
52.0	1902052050
53.0	1902053050
54.0	1902054050
55.0	1902055050
56.0	1902056050
57.0	1902057050
58.0	1902058050
59.0	1902059050
60.0	1902060050



Weldon



Heavy duty serration with pre- (1) and post-cutter (2)

Ejector pin 6.35 x 77 mm 1926500

Ejector pin 6.35 x 102 mm 1950500



ALFRA ROTABEST® HSS-CO-RQX CORE DRILL WELDON Sets



- A range of the most commonly used core drills clearly arranged in a sturdy plastic case.
- Absolute protection of the teeth tips in the rough usage operation at installation and in the workshop.
- On request, we can assemble individual sets in 12.0 to 30.0 mm diameters.

Ø mm	12.0	14.0	16.0	18.0	20.0	22.0	24.0	26.0
Cutting depth 30 mm								
Prod.-No.								
1902003025	Set of 6 ALFRA ROTABEST® HSS-CO-RQX Core drill WELDON set: incl. 1 ejector pin Prod.-No. 1926500							
	●	●	●	●		●		●
1902001025	Set of 10 ALFRA ROTABEST® HSS-CO-RQX Core drill WELDON set: incl. 2 ejector pins Prod.-No. 1926500							
	●●	●●	●	●●		●●		●
Cutting depth 50 mm								
1902003050	Set of 6 ALFRA ROTABEST® HSS-CO-RQX Core drill WELDON set: incl. 1 ejector pin Prod.-No. 1950500							
		●	●	●	●	●		●
1902001050	Set of 10 ALFRA ROTABEST® HSS-CO-RQX Core drill WELDON set: incl. 2 ejector pins Prod.-No. 1950500							
		●●	●	●●	●	●●	●	●

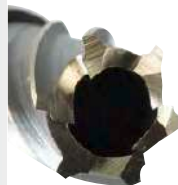

HSS-Co core drills with special geometry for the machining of superimposed metal plates (multi-layer drill) on request! (Standard core drills are unsuitable for this.)



The compatible one:

ALFRA ROTABEST® HSS-CO-ECO Core drill FEIN-QUICKIN

Are you using FEIN magnetic drilling machines and don't want to do without your ALFRA-Rotabest® core drill? Take a look at our selection of HSS and carbide-tipped core drills suitable for the various types of FEIN machines.

- Suitable for FEIN magnetic drilling machines with Quick-IN arbor.
- Special shank, 18.0 mm with 4 bearing recesses
- Steel quality: Special super high speed steel
- Internal hole 6.4 mm

Cutting depth 35 mm

Ø in mm	Prod.-No.
12.0	1909012035
13.0	1909013035
14.0	1909014035
15.0	1909015035
16.0	1909016035
17.0	1909017035
18.0	1909018035
19.0	1909019035
20.0	1909020035
21.0	1909021035
22.0	1909022035
23.0	1909023035
24.0	1909024035
25.0	1909025035
26.0	1909026035
27.0	1909027035
28.0	1909028035
29.0	1909029035
30.0	1909030035
31.0	1909031035
32.0	1909032035
Ejector pin 6.35 x 106 mm	1936500



FEIN-QUICKIN



Heavy duty serration with pre- (1) and post-cutter (2)



Prod.-No. 1936500



RÖTABEST
35 SP
ALFRA
Produkt für Profis
MADE IN
GERMANY

TCT CORE DRILLS *ALFRA ROTABEST*[®]



ALFRA ROTABEST® – TCT CORE DRILLS



Applicable on magnetic and column drills. For structural steels, hard-to-machine materials such as chrome-nickel stainless steels and non-ferrous metals such as aluminium and CuZn alloy and many more.

Advantages of the ALFRA ROTABEST® Tungsten carbide-tipped core drills:

- * High concentricity due to solid design
- * CAD-optimised cutting geometry for steady flow of chips
- * Uniquely shaped chip grooves to prevent chip jamming
- * Instant centring
- * No running off centre
- * Small torque
- * Low energy consumption
- * Rapid drill core removal by ejector pin
- * Extended tool life

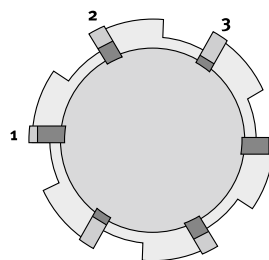

ALFRA "Chip-Breaker System"
Extremely precise drilling in 3 simple steps.
1 Pre-cutter
2 Middle cutter
3 Post-cutter

ALFRA ROTABEST® TCT CORE DRILL WELDON

CARBIDE-TIPPED

- with Weldon shank 19.0 mm
- Internal bore: Ø 12 mm = 5.0 mm
 Ø 14 - 17 mm = 6.35 mm
 Ø 18 - 50 mm = 8.0 mm
- Polished section: Pre- Middle - Post cutter
- For the highest standards in cutting and lifespan.

Suitable on:
all magnetic drilling machines with Weldon shank. ALFRA-Rotabest® (Weldon), ALFRA-Rota-Quick® Quick-change system, for BDS, Bux, Ruko, Magnetor, Euroboor, Universal, Jancy, Hougen, Magtron, Promac, Rotabroach, among others.



Ø in mm	cutting depth 35 mm	Prod.-No.
12.0		2003012035
14.0		2003014035
15.0		2003015035
16.0		2003016035
17.0		2003017035
18.0		2003018035
19.0		2003019035
20.0		2003020035
21.0		2003021035
22.0		2003022035
23.0		2003023035
24.0		2003024035
25.0		2003025035
26.0		2003026035
27.0		2003027035
28.0		2003028035
29.0		2003029035
30.0		2003030035
31.0		2003031035
32.0		2003032035
33.0		2003033035
34.0		2003034035
35.0		2003035035
Ejector pin for Ø 12 mm, 5 x 87 mm		1934500
Ejector pin for Ø 14 - 17 mm, 6.35 x 87 mm		1935500
Ejector pin for Ø 18 - 50 mm, 8 x 87 mm		2001500

Ø in mm	cutting depth 50 mm	Prod.-No.
14.0		2003014050
15.0		2003015050
16.0		2003016050
17.0		2003017050
18.0		2003018050
19.0		2003019050
20.0		2003020050
21.0		2003021050
22.0		2003022050
23.0		2003023050
24.0		2003024050
25.0		2003025050
26.0		2003026050
27.0		2003027050
28.0		2003028050
29.0		2003029050
30.0		2003030050
31.0		2003031050
32.0		2003032050
33.0		2003033050
34.0		2003034050
35.0		2003035050
36.0		2003036050
37.0		2003037050
38.0		2003038050
39.0		2003039050
40.0		2003040050
41.0		2003041050
42.0		2003042050
43.0		2003043050
44.0		2003044050
45.0		2003045050
46.0		2003046050
47.0		2003047050
48.0		2003048050
49.0		2003049050
50.0		2003050050

Ejector pin for Ø 14 - 17 mm, 6.35 x 102 mm	1950500
Ejector pin for Ø 18 - 50 mm, 8 x 102 mm	2001501

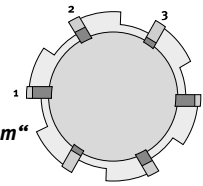

ALFRA „Chip-Breaker System“

- 1 Pre-cutter
- 2 Middle-cutter
- 3 Post-cutter

On request with shank for NITTO One-Touch

ALFRA ROTABEST® TCT CORE DRILL TYPE AL CARBIDE-TIPPED

- Heavy industrial version **with keyway and feather key**
- Long-term tests series have shown that this specialised design with keyway and feather key has proven outstanding compared to a standard 32 mm Weldon shank. Optimal containment of high torsion forces.
- Polished section: Pre- Middle - Post cutter
- Required: Tool holder with internal cooling

AL 3	MT3	Prod.-No. 20230
AL 4	MT4	Prod.-No. 20240
AL 5	MT5	Prod.-No. 20250
- On request, cutting depth of 100 mm with ejector pin 8 x 160 mm Prod.-No. 2001502



Shorter and more robust tool construction.
ALFRA design.
High concentricity.

Ø in mm	cutting depth 50 mm	Prod.-No.
51.0		2002051050
52.0		2002052050
53.0		2002053050
54.0		2002054050
55.0		2002055050
56.0		2002056050
57.0		2002057050
58.0		2002058050
59.0		2002059050
60.0		2002060050
61.0		2002061050
62.0		2002062050
63.0		2002063050
64.0		2002064050
65.0		2002065050
66.0		2002066050
67.0		2002067050
68.0		2002068050
69.0		2002069050
70.0		2002070050
71.0		2002071050
72.0		2002072050
73.0		2002073050
74.0		2002074050
75.0		2002075050
76.0		2002076050
77.0		2002077050
78.0		2002078050
79.0		2002079050
80.0		2002080050
81.0		2002081050
82.0		2002082050
83.0		2002083050
84.0		2002084050
85.0		2002085050
86.0		2002086050
87.0		2002087050
88.0		2002088050
89.0		2002089050
90.0		2002090050
91.0		2002091050
92.0		2002092050
93.0		2002093050
94.0		2002094050
95.0		2002095050
96.0		2002096050
97.0		2002097050
98.0		2002098050
99.0		2002099050
100.0		2002100050

Advantages ALFRA carbide-tipped core drills “Heavy industrial version”

- Perfect gating behaviour - even at the first drill hole
- Excellent centring properties
- Low cutting pressure - low power usage
- Vibration-free working
- Chip distribution – no chip jamming
- Drilling depth can be reached in a single operation
- Drill core can be easily ejected

ALFRA “Chip-Breaker System”

- 1 Pre-cutter
- 2 Middle cutter
- 3 Post-cutter

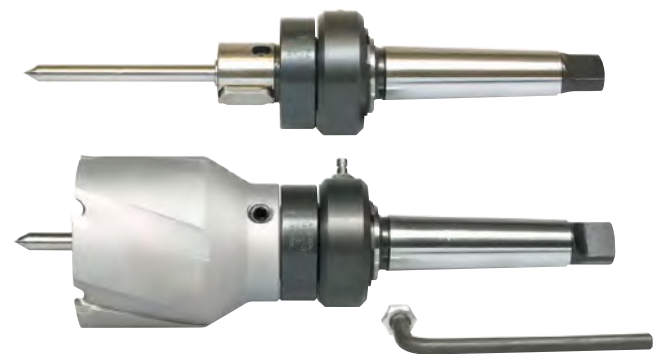
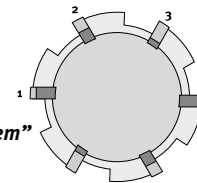

Prod.-No. 20230

Ejector pin 8 x 102 mm	2001501
Tool holder AL 2/MT 2	20220
Tool holder AL 3/MT 3	20230
Tool holder AL 4/MT 4	20240
Tool holder AL 5/MT 5	20250

Not suitable for automatic feed!

ALFRA ROTABEST® TCT CORE DRILL WELDON RAIL

CARBIDE-TIPPED

- With Weldon shank 19.0 mm
- Internal bore 6.35 mm
- For highest requirements in cutting and durability when drilling railway tracks
- Polished surface: Pre – Middle – Post cutter

Suitable for:
all portable magnetic drilling machines with 19 mm Weldon shank, especially for rail drilling units from the following manufacturers:

- Cembre
- Erico
- KKT
- Dubuis
- Universal
- Magtron
- Rotabroach



Ø in mm	cutting depth 25 mm	Prod.-No.
19.0		2005019025
20.0		2005020025
21.0		2005021025
22.0		2005022025
23.0		2005023025
24.0		2005024025
25.0		2005025025
26.0		2005026025
27.5		2005027525
28.0		2005028025
30.0		2005030025
31.0		2005031025
32.0		2005032025
33.0		2005033025
34.0		2005034025
36.0		2005036025
Ejector pin 6.35 x 77 mm		1926500

Ø in mm	cutting depth 50 mm	Prod.-No.
19.0		2005019050
20.0		2005020050
21.0		2005021050
22.0		2005022050
23.0		2005023050
24.0		2005024050
25.0		2005025050
26.0		2005026050
27.5		2005027550
28.0		2005028050
30.0		2005030050
31.0		2005031050
32.0		2005032050
33.0		2005033050
34.0		2005034050
36.0		2005036050
Ejector pin 6.35 x 102 mm		1950500

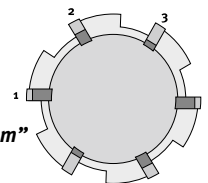

ALFRA "Chip-Breaker System"

- 1 Pre-cutter
- 2 Middle-cutter
- 3 Post-cutter

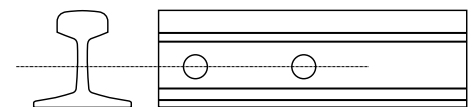

ALFRA ROTABEST® TCT CORE DRILL FEIN THREAD (M18X1.5) / FEIN-QUICKIN - CARBIDE-TIPPED

- 2008... with threaded arbor internal thread M18 x 1.5
- Also suitable for Hitachi machines
- 2009... with Quick-IN arbor
- Suitable on FEIN magnetic drilling machines with Quick-IN arbor



Prod.-No. 2008...



Threaded arbor M18 x 6P1.5

Ø in mm	Prod.-No.	Prod.-No.
	M18 x 1.5 Cutting depth 50 mm	QuickIN Cutting depth 35 mm
12.0	2008012050	2009012035
13.0	2008013050	2009013035
14.0	2008014050	2009014035
15.0	2008015050	2009015035
16.0	2008016050	2009016035
17.0	2008017050	2009017035
18.0	2008018050	2009018035
19.0	2008019050	2009019035
20.0	2008020050	2009020035
21.0	2008021050	2009021035
22.0	2008022050	2009022035
23.0	2008023050	2009023035
24.0	2008024050	2009024035
25.0	2008025050	2009025035
26.0	2008026050	2009026035
27.0	2008027050	2009027035
28.0	2008028050	2009028035
29.0	2008029050	2009029035
30.0	2008030050	2009030035
31.0	2008031050	2009031035
32.0	2008032050	2009032035
33.0	2008033050	2009033035
34.0	2008034050	2009034035
35.0	2008035050	2009035035
36.0	2008036050	2009036035
37.0	2008037050	2009037035
38.0	2008038050	2009038035
39.0	2008039050	2009039035
40.0	2008040050	2009040035
41.0	2008041050	2009041035
42.0	2008042050	2009042035
43.0	2008043050	2009043035
44.0	2008044050	2009044035
45.0	2008045050	2009045035
46.0	2008046050	2009046035
47.0	2008047050	2009047035
48.0	2008048050	2009048035
49.0	2008049050	2009049035
50.0	2008050050	2009050035
51.0	2008051050	2009051035
52.0	2008052050	2009052035
53.0	2008053050	2009053035
54.0	2008054050	2009054035
55.0	2008055050	2009055035
57.0	2008057050	2009057035
58.0	2008058050	2009058035
59.0	2008059050	2009059035
60.0	2008060050	2009060035
61.0	2008061050	2009061035
62.0	2008062050	2009062035
63.0	2008063050	2009063035
64.0	2008064050	2009064035
65.0	2008065050	2009065035
Ejector pin 6.35 x 106 mm	-	1936500



Prod.-No. 2009...



Prod.-No. 1936500

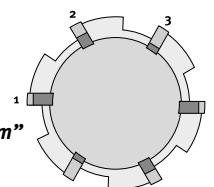

ALFRA "Chip-Breaker System"
 1 Pre-cutter
 2 Middle-cutter
 3 Post-cutter

TCT-HOLE SAWS IN USE



TCT-Hole Saws – short-/long type



Plastic



Poroton brick stone



Stainless steel





TCT-Hole Saws – MBS type



Sanitary pipes – type SML



Checker plate (stainless steel)



MBS Pro
Use on Rotabest Magnetic Drilling Machine
with MT3 – Arbor Prod.-No.: 0734003

ALFRA TCT-HOLE SAWS – SHORT TYPE

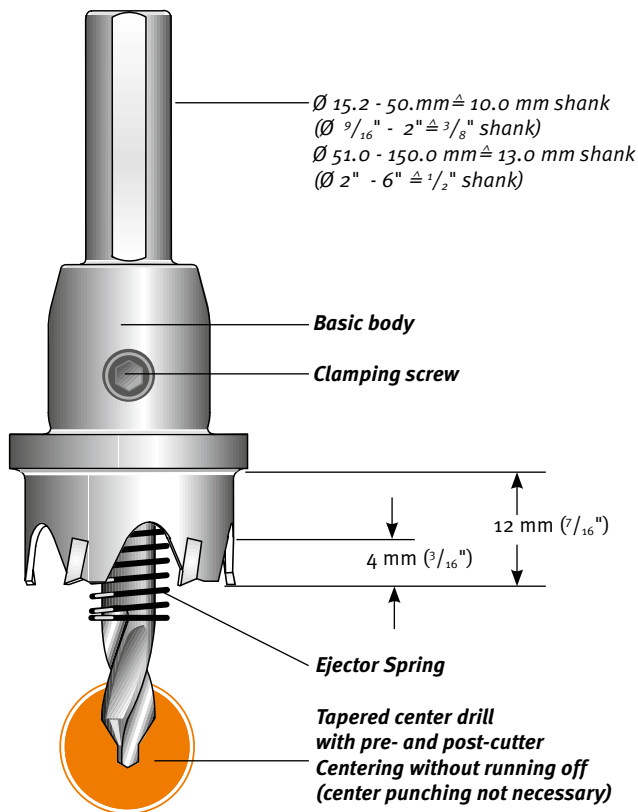

EDELSTAHL
STAINLESS STEEL



The application area of TCT Hole Saws differs from HSS-Bi-Metal Hole Saws. With ALFRA TCT Hole Saws, suitable to economically process stainless steel up to 2 mm ($\frac{1}{16}''$), unalloyed steels up to 4 mm ($\frac{3}{16}''$), plastics, PVC, aluminium, zinc, gypsum plaster boards and lightweight building boards, as well as asbestos. Do not use automatic feed, when working with pillar drilling machines. For the use on portable- and pillar drilling machines. Do not use automatic feed, when working with pillar drilling machines.

Features:

- High concentric running exactness through solid construction.
- CAD-optimized cutting angles with specially ground section ensures high cutting capacity and long tool life.
- Quick removal of drilled core through ejector spring for all hole saws up to 150 mm ($5-29/32''$) \varnothing .
- Carbide tipping enables repeated re-grinding.
- ALFRA hole saws are repairable. In the event of a tooth breaking, it can easily be replaced and resharpened.
- Exchangeable center pin.
- Use of MT tool holders from $\varnothing 31 \text{ mm}$ ($1-7/32''$).
- For use on hand drilling machines (recommended up to max. $\varnothing 40 \text{ mm}$; $1-9/16''$) or stationary machines.

Tips:

- At thicker materials: cut 2-3 mm ($\frac{1}{16}'' - 7/64''$) per cutting process, remove chips afterwards.
- When cutting metals, a high- grade cutting oil should be used.
Exception: Do not use cutting oil when using cast iron, use paraffin instead of oil when cutting aluminium.
- **Keep in mind: Always wear safety goggles.**

Another special technical feature:

From $\varnothing 15.2 \text{ mm}$ ($\frac{3}{16}''$) to 30.0 mm ($1-1/8''$), the hole saw is made of one piece.
From $\varnothing 31.0 \text{ mm}$ ($1-3/16''$) we use specially hardened tool holders to compensate for the torsional power in case of heavy operation, which avoids early shearing off of the tool holder shank.
In terms of construction not comparable with any other make.



ALFRA TCT-HOLE SAWS – SHORT TYPE

Ø mm	Ø Inches	No. of teeth	Prod.-No.
Ø 15.2		4	0600152
Ø 16.0	5/8"	4	0600160
Ø 17.0		4	0600170
Ø 18.0	11/16"	4	0600180
Ø 18.6		4	0600186
Ø 19.0	3/4"	4	0600190
Ø 20.0		5	0600200
Ø 20.4		5	0600204
Ø 21.0	13/16"	5	0600210
Ø 22.0		5	0600220
Ø 22.5		5	0600225
Ø 23.0	7/8"	5	0600230
Ø 24.0	15/16"	5	0600240
Ø 25.0		5	0600250
Ø 26.0	1"	5	0600260
Ø 27.0	1-1/16"	5	0600270
Ø 28.0		5	0600280
Ø 28.3		5	0600283
Ø 29.0	1-1/8"	5	0600290
Ø 30.0	1-3/16"	5	0600300
Ø 31.0		6	0600310
Ø 32.0	1-1/4"	6	0600320
Ø 33.0		6	0600330
Ø 34.0	1-5/16"	6	0600340
Ø 35.0	1-3/8"	6	0600350
Ø 36.0		6	0600360
Ø 37.0	1-7/16"	7	0600370
Ø 38.0		7	0600380
Ø 39.0	1-1/2"	7	0600390
Ø 40.0	1-9/16"	7	0600400
Ø 41.0		8	0600410
Ø 42.0	1-5/8"	8	0600420
Ø 43.0	1-11/16"	8	0600430
Ø 44.0		8	0600440
Ø 45.0	1-3/4"	8	0600450
Ø 46.0		8	0600460
Ø 47.0	1-13/16"	9	0600470
Ø 48.0	1-7/8"	9	0600480
Ø 49.0		9	0600490
Ø 50.0	1-15/16"	9	0600500
Ø 51.0	2"	9	0600510
Ø 52.0		10	0600520
Ø 53.0	2-1/16"	10	0600530
Ø 54.0	2-1/8"	10	0600540
Ø 55.0		10	0600550
Ø 56.0	2-3/16"	10	0600560
Ø 57.0	2-1/4"	10	0600570
Ø 58.0		10	0600580
Ø 59.0	2-5/16"	10	0600590
Ø 60.0	2-3/8"	10	0600600
Ø 61.0		11	0600610
Ø 62.0	2-7/16"	11	0600620
Ø 63.0		11	0600630
Ø 64.0	2-1/2"	11	0600640
Ø 65.0		11	0600650
Ø 66.0	2-9/16"	12	0600660
Ø 67.0	2-5/8"	12	0600670
Ø 68.0		12	0600680
Ø 69.0	2-11/16"	12	0600690
Ø 70.0	2-3/4"	12	0600700
Ø 71.0		12	0600710
Ø 72.0	2-13/16"	13	0600720
Ø 73.0	2-7/8"	13	0600730
Ø 74.0	2-15/16"	13	0600740
Ø 75.0		13	0600750
Ø 76.0	3"	13	0600760

Ø mm	Ø Inches	No. of teeth	Prod.-No.
Ø 77.0		13	0600770
Ø 78.0	3-1/16"	14	0600780
Ø 79.0	3-1/8"	14	0600790
Ø 80.0		14	0600800
Ø 81.0	3-3/16"	14	0600810
Ø 82.0		14	0600820
Ø 83.0	3-1/4"	14	0600830
Ø 84.0	3-5/16"	15	0600840
Ø 85.0		15	0600850
Ø 86.0	3-3/8"	15	0600860
Ø 87.0	3-7/16"	15	0600870
Ø 88.0		15	0600880
Ø 89.0	3-1/2"	16	0600890
Ø 90.0	3-9/16"	16	0600900
Ø 91.0		16	0600910
Ø 92.0	3-5/8"	16	0600920
Ø 93.0		16	0600930
Ø 94.0	3-11/16"	16	0600940
Ø 95.0	3-3/4"	17	0600950
Ø 96.0		17	0600960
Ø 97.0	3-13/16"	17	0600970
Ø 98.0	3-7/8"	17	0600980
Ø 99.0		17	0600990
Ø 100.0	3-15/16"	17	0601000
Ø 105.0	4"	18	0601050
Ø 110.0		18	0601100
Ø 115.0	4-1/2"	20	0601150
Ø 120.0		20	0601200
Ø 125.0		20	0601250
Ø 130.0	5"	20	0601300
Ø 135.0		24	0601350
Ø 140.0	5-1/2"	24	0601400
Ø 145.0		24	0601450
Ø 150.0		24	0601500



Prod.-No. 0600001

Set Metric

Set Metric

Prod.-No.

0600001

Contents:

1 each of Ø 16 / 20 / 25 / 32 / 40 mm
2 Allen Keys

HSS-Spare Drill with tapered center tip



from Ø 15.2 - 100.0 Ø 6x50 mm 0602650
from Ø 101.0 - 150.0 Ø 8x50 mm 0602850

MT Arbors



MT-2 (Ø 31.0 - 100.0 mm) 0734002
MT-3 (Ø 31.0 - 150.0 mm) 0734003

ALS Arbors

ALS 1 (Shank 10 mm) 060106
ALS 3 (Shank 13 mm) 060136
ALS 4 (Shank 13 mm) 060138

SDS Arbor



SDS arbor shank 060sd56
(for use with Ø 31.0 - 100.0 mm)

Spare Ejector



from Ø 15.2 - 150.0 Ø 6 mm 0602006

Coolant ALFRA

ALFRA 2000

For mild steel DIN S233, 250 ml 21010

ALFRA 4000

For titanium and manganese-carbon steels
300 ml 21040



Prod.-No. 21010



Prod.-No. 21040

ALFRA TCT-HOLE SAWS – LONG TYPE

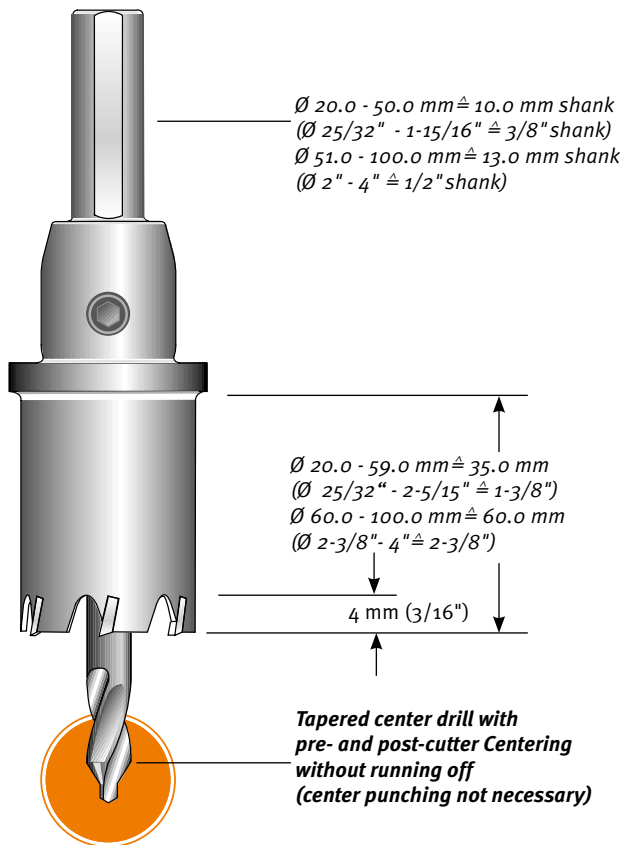

Features:

- Especially developed for the use on pipes, vaulted materials, for unalloyed and alloyed steels, nonferrous metals, plastics as well as glass fibre reinforced plastic.
- For material thickness up to 4 mm (3/16"), 2 mm (1/16") stainless steel.
- For use on hand drilling machines, recommended up to max. $\varnothing 40 \text{ mm}$ (1-9/16") or stationary machines.

Tips:

- Start drilling operation with light pressure, when drilling pipes. Avoid pendulum motions.
- **Keep in mind: Always wear safety goggles.**



ALFRA TCT-HOLE SAWS – LONG TYPE

Ø mm	Ø Inches	No. of teeth	Prod.-No.	Ø mm	Ø Inches	No. of teeth	Prod.-No.	Ø mm	Ø Inches	No. of teeth	Prod.-No.
Ø 16.0	5/8"	4	0700160	Ø 54.0	2-1/8"	12	0700540	Ø 92.0	3-5/8"	20	0700920
Ø 17.0		4	0700170	Ø 55.0		12	0700550	Ø 93.0		20	0700930
Ø 18.0	11/16"	4	0700180	Ø 56.0	2-3/16"	12	0700560	Ø 94.0	3-11/16"	22	0700940
Ø 19.0	3/4"	4	0700190	Ø 57.0	2-1/4"	12	0700570	Ø 95.0	3-3/4"	22	0700950
Ø 20.0		5	0700200	Ø 58.0		12	0700580	Ø 96.0		22	0700960
Ø 21.0	13/16"	5	0700210	Ø 59.0	2-5/16"	12	0700590	Ø 97.0	3-13/16"	22	0700970
Ø 22.0		5	0700220	Ø 60.0	2-3/8"	14	0700600	Ø 98.0	3-7/8"	22	0700980
Ø 23.0	7/8"	5	0700230	Ø 61.0		14	0700610	Ø 99.0		22	0700990
Ø 24.0	15/16"	6	0700240	Ø 62.0	2-7/16"	14	0700620	Ø 100.0	3-15/16"	22	0701000
Ø 25.0		6	0700250	Ø 63.0		14	0700630				
Ø 26.0	1"	6	0700260	Ø 64.0	2-1/2"	14	0700640				
Ø 27.0	1-1/16"	6	0700270	Ø 65.0		14	0700650				
Ø 28.0		6	0700280	Ø 66.0	2-9/16"	14	0700660				
Ø 29.0	1-1/8"	6	0700290	Ø 67.0	2-5/8"	16	0700670				
Ø 30.0	1-3/16"	6	0700300	Ø 68.0		16	0700680				
Ø 31.0		8	0700310	Ø 69.0	2-11/16"	16	0700690				
Ø 32.0	1-1/4"	8	0700320	Ø 70.0	2-3/4"	16	0700700				
Ø 33.0		8	0700330	Ø 71.0		16	0700710				
Ø 34.0	1-5/16"	8	0700340	Ø 72.0	2-13/16"	16	0700720				
Ø 35.0	1-3/8"	8	0700350	Ø 73.0	2-7/8"	16	0700730				
Ø 36.0		8	0700360	Ø 74.0	2-15/16"	16	0700740				
Ø 37.0	1-7/16"	8	0700370	Ø 75.0		16	0700750				
Ø 38.0		8	0700380	Ø 76.0	3"	18	0700760				
Ø 39.0	1-1/2"	8	0700390	Ø 77.0		18	0700770				
Ø 40.0	1-9/16"	10	0700400	Ø 78.0	3-1/16"	18	0700780				
Ø 41.0		10	0700410	Ø 79.0	3-1/8"	18	0700790				
Ø 42.0	1-5/8"	10	0700420	Ø 80.0		18	0700800				
Ø 43.0	1-11/16"	10	0700430	Ø 81.0	3-3/16"	18	0700810				
Ø 44.0		10	0700440	Ø 82.0		18	0700820				
Ø 45.0	1-3/4"	10	0700450	Ø 83.0	3-1/4"	18	0700830				
Ø 46.0		10	0700460	Ø 84.0	3-5/16"	20	0700840				
Ø 47.0	1-13/16"	10	0700470	Ø 85.0		20	0700850				
Ø 48.0	1-7/8"	10	0700480	Ø 86.0	3-3/8"	20	0700860				
Ø 49.0		10	0700490	Ø 87.0	3-7/16"	20	0700870				
Ø 50.0	1-15/16"	12	0700500	Ø 88.0		20	0700880				
Ø 51.0	2"	12	0700510	Ø 89.0	3-1/2"	20	0700890				
Ø 52.0		12	0700520	Ø 90.0	3-9/16"	20	0700900				
Ø 53.0	2-1/16"	12	0700530	Ø 91.0		20	0700910				

HSS-Spare Drill with tapered center tip



from Ø 16,0 - 30,0 Ø 6x80 mm	0732680
from Ø 31,0 - 59,0 Ø 6x80 mm	0732880
from Ø 60,0 - 100,0 Ø 8x100 mm	0702800

MT Arbors



MT-2 (from Ø 31.0)	0734002
MT-3 (from Ø 31.0)	0734003

ALS Arbors

ALS 2 (Shank 10 mm)	060108
ALS 4 (Shank 13 mm)	060138

SDS Arbor



SDS arbor shank (for use with Ø 31 - 59 mm)	060sds6
--	---------

HIGHLY RECOMMENDET ACCESSORIES – COOLANT AND LUBRICANT!

ALFRA 2000

ALFRA 2000 is a fully synthetic cutting oil, developed for high-quality cutting, threading and drilling of metals of any degree of hardness, ferrous metal, steel alloys, stainless steel, copper, aluminium and their alloys.

ALFRA 2000 is free of hydrocarbon, sulphur and chlorine.



ALFRA 4000

Suitable for core drilling applications with ALFRA cutters. Also ideal for twist drilling, thread tapping, reaming, countersinking, and difficult cutting applications. It meets to the requirements of work hygiene and safety.

ALFRA 4000 is a pump spray, free from propellant gas ideal for drilling and tapping of high-alloy, stainless steels; chromium nickel steels; titanium and manganese-carbon steels



	Prod.-No.
Aerosol can 250 ml	21010
5 ltr. Plastic container	21012
60 ltr. Barrel	21021

	Prod.-No.
Aerosol can 300 ml	21040

ALFRA TCT-HOLE SAWS – MBS-LIGHT

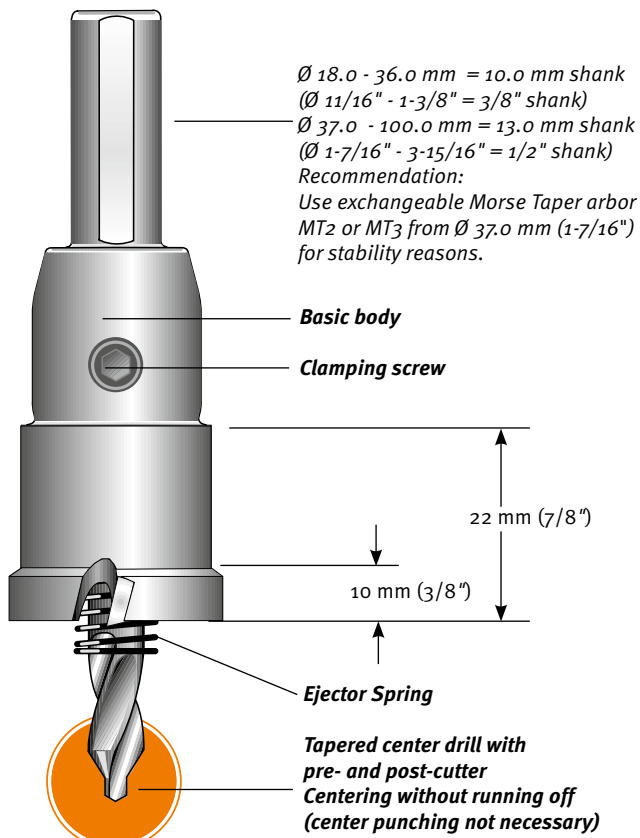

This TCT Hole Saw is a multi-range Hole Saw for the universal use up to a material thickness of max. 10 mm (3/8") (without ejector spring). Through its solid construction and an enhanced cutting geometry (Registered Utility Model No. 202 03 232 9), an improved cutting behaviour combined with a high cutting capacity and tool life, is achieved.

For the use on flat steel, as well as on pipes and vaulted materials. Cutting of overlapping holes is possible.

For use on stationary and hand drilling machines (recommended up to max. $\varnothing 40 \text{ mm}$; 1-9/16").

- **Portable drilling Machines:** up to 4 mm (1/8") material thickness
- **Stationary drilling Machines:** up to 10 mm (3/8") material thickness (for material thickness over 6 mm (15/64"), it is necessary to settle and empty the chips several times).

In case of heavy operation, we recommend Morse Taper Tool Holders, which are suitable from $\varnothing 37 \text{ mm}$ (1-7/16").

Advantage: All MBS-Light type TCT Hole Saws are equipped with an ejector spring. The cut material is self-ejecting.

Another special technical feature:

From $\varnothing 37 \text{ mm}$ (1-7/16"), specially hardened tool holders are used to compensate for the torsional power in case of heavy operation which avoids early shearing off of the tool holder shank.

In terms of construction not comparable with any other make.

MBS – for almost limitless use

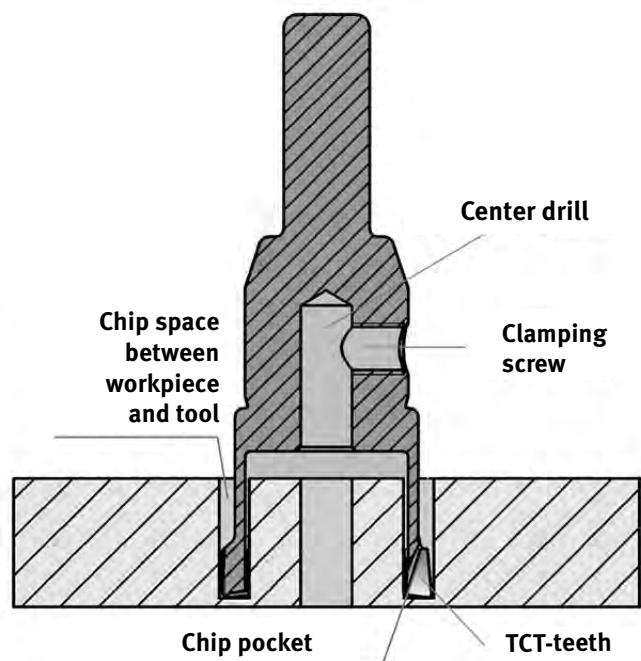

ALFRA TCT-HOLE SAWS – MBS-LIGHT

Ø mm	Ø Inches	No. of teeth	Prod.-No.	Ø mm	Ø Inches	No. of teeth	Prod.-No.
Ø 18.0	11/16"	4	0730018	Ø 79.0	3-1/8"	12	0730079
Ø 18.6		4	07300186	Ø 80.0		12	0730080
Ø 19.0	3/4"	4	0730019	Ø 81.0	3-3/16"	12	0730081
Ø 20.0		4	0730020	Ø 82.0		12	0730082
Ø 20.4		4	07300204	Ø 83.0	3-1/4"	12	0730083
Ø 21.0	13/16"	4	0730021	Ø 84.0	3-5/16"	12	0730084
Ø 22.0		4	0730022	Ø 85.0		12	0730085
Ø 22.5		4	07300225	Ø 86.0	3-3/8"	14	0730086
Ø 23.0	7/8"	4	0730023	Ø 87.0	3-7/16"	14	0730087
Ø 24.0	15/16"	4	0730024	Ø 88.0		14	0730088
Ø 25.0		4	0730025	Ø 89.0	3-1/2"	14	0730089
Ø 26.0	1"	6	0730026	Ø 90.0	3-9/16"	14	0730090
Ø 27.0	1-1/16"	6	0730027	Ø 91.0		14	0730091
Ø 28.0		6	0730028	Ø 92.0	3-5/8"	14	0730092
Ø 29.0	1-1/8"	6	0730029	Ø 93.0		14	0730093
Ø 30.0	1-3/16"	6	0730030	Ø 94.0	3-11/16"	14	0730094
Ø 31.0		6	0730031	Ø 95.0	3-3/4"	14	0730095
Ø 32.0	1-1/4"	6	0730032	Ø 96.0		14	0730096
Ø 33.0		6	0730033	Ø 97.0	3-13/16"	14	0730097
Ø 34.0	1-5/16"	6	0730034	Ø 98.0	3-7/8"	14	0730098
Ø 35.0	1-3/8"	6	0730035	Ø 99.0		14	0730099
Ø 36.0		6	0730036	Ø 100.0	3-15/16"	14	0730100

From Ø 37.0 mm (1-7/16") we recommend the use of MT arbors

Ø 37.0	1-7/16"	6	0730037
Ø 38.0		6	0730038
Ø 39.0	1-1/2"	6	0730039
Ø 40.0	1-9/16"	6	0730040
Ø 41.0		6	0730041
Ø 42.0	1-5/8"	6	0730042
Ø 43.0	1-11/16"	6	0730043
Ø 44.0		6	0730044
Ø 45.0	1-3/4"	6	0730045
Ø 46.0		6	0730046
Ø 47.0	1-13/16"	6	0730047
Ø 48.0	1-7/8"	6	0730048
Ø 49.0		6	0730049
Ø 50.0	1-15/16"	6	0730050
Ø 51.0	2"	6	0730051
Ø 52.0		6	0730052
Ø 53.0	2-1/16"	6	0730053
Ø 54.0	2-1/8"	6	0730054
Ø 55.0		6	0730055
Ø 56.0	2-3/16"	6	0730056
Ø 57.0	2-1/4"	6	0730057
Ø 58.0		6	0730058
Ø 59.0	2-5/16"	6	0730059
Ø 60.0	2-3/8"	8	0730060
Ø 61.0		8	0730061
Ø 62.0	2-7/16"	8	0730062
Ø 63.0		8	0730063
Ø 64.0	2-1/2"	8	0730064
Ø 65.0		8	0730065
Ø 66.0	2-9/16"	8	0730066
Ø 67.0	2-5/8"	8	0730067
Ø 68.0		8	0730068
Ø 69.0	2-11/16"	8	0730069
Ø 70.0	2-3/4"	8	0730070
Ø 71.0		10	0730071
Ø 72.0	2-13/16"	10	0730072
Ø 73.0	2-7/8"	10	0730073
Ø 74.0	2-15/16"	10	0730074
Ø 75.0		10	0730075
Ø 76.0	3"	10	0730076
Ø 77.0		12	0730077
Ø 78.0	3-1/16"	12	0730078

HSS-Spare Drill with tapered center tip



from Ø 18.0 - 60.0	Ø 6x50 mm	0602650
from Ø 61.0 - 100.0	Ø 8x50 mm	0602850

(old design)

MT Arbors



MT-2 (from Ø 37.0 mm)	0734002
MT-3 (from Ø 37.0 mm)	0734003

ALS Arbors

ALS 3 (Shank 13 mm)	060136
ALS 4 (Shank 13 mm)	060138

Weldon adaptor



from Ø 37.0 mm	060WD
----------------	-------

(incl. ejector pin Prod. No. 1950500)

Spare Ejector

For tapered center drill



from Ø 18.0 - 60.0 mm	Ø 6 mm	0732006
from Ø 61.0 - 100.0 mm	Ø 8 mm	0732008



Drilling in checker sheet



Drilling in square profiles



Drilling in flat steel



Drilling in pipes

ALFRA TCT-HOLE SAWS – MBS-PRO

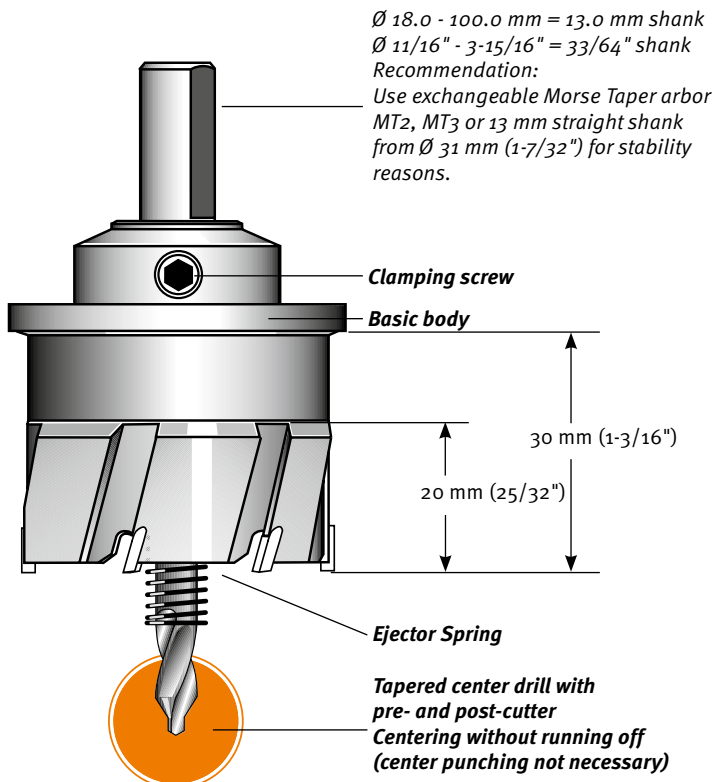

EDELSTAHL
STAINLESS STEEL

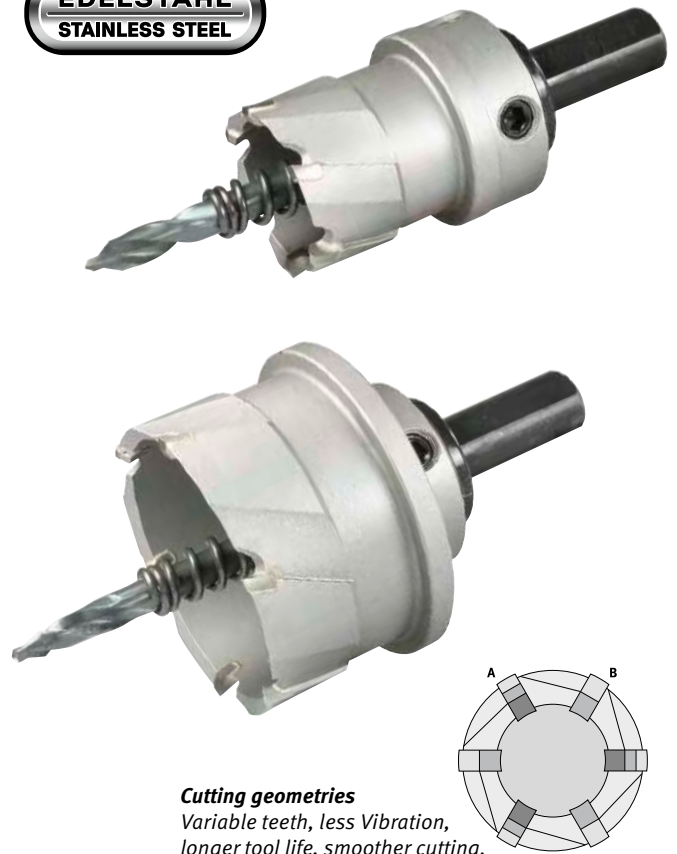

Cutting geometries
Variable teeth, less Vibration,
longer tool life, smoother cutting.

MBS-Multirange Hole Saws for universal use. **Max. cutting depth 20 mm (25/32")**

Suitable for flat materials but also for pipes and curved surfaces. Cutting of overlapping holes is possible. CAD optimized precision tools with high cutting performance and durability.

For use on stationary and portable drilling machines (recommended up to max. Ø 40 mm; 1-9/16")

- **Portable drilling Machines:** up to 6 mm (15/64") material thickness
- **Stationary drilling Machines:** up to 20 mm (25/32") material thickness at cutting depths from 6 mm (15/64") we recommend clearing the chips.

MBS hole saws can be resharpened, and it is possible to replace broken out teeth depending on the condition of the hole saw.

Advantages: All Alfra TCT Hole Saws MBS-Pro type are equipped with an ejector spring. The cut material is self-ejecting.

Another special technical feature:
From Ø 31 mm (1-7/32"), we use specially hardened tool holders to compensate for the torsional power in case of heavy operation, which avoids early shearing off of the tool holder shank.
In terms of construction not comparable with any other make.

MBS – for almost limitless use

e.g., on Rotabest Magnetic Drilling Machine (with MT2 or MT3 – arbors) and Weldon adaptor Prod.-No. 060WD on Machines with Weldon Shank.



ALFRA TCT-HOLE SAWS – MBS-PRO

Ø mm	Ø Inches	No. of teeth	Prod.-No.
Ø 18.0	11/16"	6	0760018
Ø 18.6		6	07600186
Ø 19.0	3/4"	6	0760019
Ø 20.0		6	0760020
Ø 20.4		6	07600204
Ø 21.0	13/16"	6	0760021
Ø 22.0		6	0760022
Ø 22.5		6	07600225
Ø 23.0	7/8"	6	0760023
Ø 24.0	15/16"	6	0760024
Ø 25.0		6	0760025
Ø 26.0	1"	6	0760026
Ø 27.0	1-1/16"	6	0760027
Ø 28.0		6	0760028
Ø 28.3		6	07600283
Ø 29.0	1-1/8"	6	0760029
Ø 30.0	1-3/16"	6	0760030
As from Ø 31.0 mm (1-7/32") we recommend the use of MT arbors			
Ø 31.0		6	0760031
Ø 32.0	1-1/4"	6	0760032
Ø 33.0		6	0760033
Ø 34.0	1-5/16"	6	0760034
Ø 35.0	1-3/8"	6	0760035
Ø 36.0		6	0760036
Ø 37.0	1-7/16"	6	0760037
Ø 38.0		6	0760038
Ø 39.0	1-1/2"	6	0760039
Ø 40.0	1-9/16"	6	0760040
Ø 41.0		6	0760041
Ø 42.0	1-5/8"	6	0760042
Ø 43.0	1-11/16"	6	0760043
Ø 44.0		6	0760044
Ø 45.0	1-3/4"	6	0760045
Ø 46.0		6	0760046
Ø 47.0	1-13/16"	6	0760047
Ø 48.0	1-7/8"	6	0760048
Ø 49.0		6	0760049
Ø 50.0	1-15/16"	6	0760050
Ø 51.0	2"	6	0760051
Ø 52.0		6	0760052
Ø 53.0	2-1/16"	6	0760053
Ø 54.0	2-1/8"	6	0760054
Ø 55.0		6	0760055
Ø 56.0	2-3/16"	6	0760056
Ø 57.0	2-1/4"	6	0760057
Ø 58.0		6	0760058
Ø 59.0	2-5/16"	6	0760059
Ø 60.0	2-3/8"	8	0760060
Ø 61.0		8	0760061
Ø 62.0	2-7/16"	8	0760062
Ø 63.0		8	0760063
Ø 64.0	2-1/2"	8	0760064
Ø 65.0		8	0760065
Ø 66.0	2-9/16"	8	0760066
Ø 67.0	2-5/8"	8	0760067
Ø 68.0		8	0760068
Ø 69.0	2-11/16"	8	0760069
Ø 70.0	2-3/4"	8	0760070
Ø 71.0		10	0760071
Ø 72.0	2-13/16"	10	0760072
Ø 73.0	2-7/8"	10	0760076
Ø 74.0	2-15/16"	10	0760074
Ø 75.0		10	0760075

Ø mm	Ø Inches	No. of teeth	Prod.-No.
For drilling stainless steel from Ø 76.0 mm we recommend using Rotabest AL cutters (Prod.-No. 200207...)			
Ø 76.0	3"	10	0760076
Ø 77.0		12	0760077
Ø 78.0	3-1/16"	12	0760078
Ø 79.0	3-1/8"	12	0760079
Ø 80.0		12	0760080
Ø 81.0	3-3/16"	12	0760081
Ø 82.0		12	0760082
Ø 83.0	3-1/4"	12	0760083
Ø 84.0	3-5/16"	12	0760084
Ø 85.0		12	0760085
Ø 86.0	3-3/8"	14	0760086
Ø 87.0	3-7/16"	14	0760087
Ø 88.0		14	0760088
Ø 89.0	3-1/2"	14	0760089
Ø 90.0	3-9/16"	14	0760090
Ø 91.0		14	0760091
Ø 92.0	3-5/8"	14	0760092
Ø 93.0		14	0760093
Ø 94.0	3-11/16"	14	0760094
Ø 95.0	3-3/4"	14	0760095
Ø 96.0		14	0760096
Ø 97.0	3-13/16"	14	0760097
Ø 98.0	3-7/8"	14	0760098
Ø 99.0		14	0760099
Ø 100.0	3-15/16"	14	0760100



Drilling structured sheet metals



Drilling tubes



Drilling flat steels



Free-hand drilling up to Ø 30 mm

HSS-Spare Drill with tapered center tip



from Ø 18.0 - 60.0 Ø 6x80 mm 0732680
from Ø 61.0 - 100.0 Ø 8x80 mm 0732880

MT Arbors



MT-2 (Ø 31.0 - 100.0 mm) 0734002
MT-3 (Ø 31.0 - 100.0 mm) 0734003

ALS Arbors

ALS 3 (Shank 13 mm) 060136
ALS 4 (Shank 13 mm) 060138

Weldon adapter



from Ø 31.0 mm 060WD
(incl. ejector pin Prod. No. 1950500)

Spare Ejector



For tapered center drill
from Ø 15.2 - 60.0 Ø 6 mm 0762006
suitable for spare drill Ø 6 mm

ALFRA HSS-BI-METAL HOLE SAWS



ALFRA HSS-BI-METAL HOLE SAWS

Features:

- High concentricity.
- With solid base plate, thus more threads and higher stability as well as concentric running exactness.
- For material from 2 mm – with positive chipping and cutting angles as well as combi-toothing 4/6 tpi. This variable spacing provides a more even cut, for a minor generation of vibrations and heat. Lower expenditure of energy when cutting.
- Cutting Depth: 38 mm (1-1/2").
- Lateral slots help to remove the core.
- Suitable for unalloyed steel (up to 700 N/mm²), nonferrous metals, light metals, plastics, gypsum, pulp wood- and plywood boards, lightweight building boards and general wood processing.
- Drill bit exchangeable with other commercially available arbors.



Also steel/stainless steel up to approx. 3 mm, can be worked easily (for frequent use, we recommend our TCT Hole Saws).



...designed to work on softwoods.



ALFRA – HSS-BI-METAL HOLE SAWS

ALFRA HSS-Bi-Metal Hole Saws are applicable in portable and pillar drilling machines. When using pillar drilling machines, use manual feed only.

Features:

- High concentricity.
- With solid base plate, thus more threads and higher stability as well as concentric running exactness.
- With positive chipping and cutting angles as well as combi-toothing 4/6 tpi. This variable spacing provides a more even cut, for a minor generation of vibrations and heat. Lower expenditure of energy when cutting.
- Cutting Depth: 38 mm (1-1/2").
- Lateral slots help to remove the core.
- Suitable for unalloyed steel (up to 700 N/mm²), nonferrous metals, light metals, plastics, gypsum, pulp wood- and plywood boards, lightweight building boards and general wood processing.
- Drill bit exchangeable with other commercially available arbors.

Tip:

Start drilling operation with light pressure. Continue with light and steady pressure, avoid pendulum motion, follow the speed chart, use coolant. When cutting wood or wood substitutes, remove drill dust in time.



Combi toothing 4/6 tpi



from Ø 14.0 to 210 mm available

Saw-Ø mm	Inches	Prod.-No.
14.0	9/16"	0500014
16.0	5/8"	0500016
17.0	11/16"	0500017
19.0	3/4"	0500019
20.0	15/19"	0500020
21.0	13/16"	0500021
22.0	7/8"	0500022
24.0	15/16"	0500024
25.0	1"	0500025
27.0	11/16"	0500027
29.0	1-1/8"	0500029
30.0	1-3/16"	0500030
32.0	1-1/4"	0500032
33.0	1-5/16"	0500033
35.0	1-3/8"	0500035
37.0	1-7/16"	0500037
38.0	1-1/2"	0500038
40.0	1-9/16"	0500040
41.0	1-5/8"	0500041
43.0	1-11/16"	0500043
44.0	1-3/4"	0500044
46.0	1-13/16"	0500046
48.0	1-7/8"	0500048
51.0	2"	0500051
52.0	2-1/16"	0500052
54.0	2-1/8"	0500054
57.0	2-1/4"	0500057
59.0	2-5/16"	0500059
60.0	2-3/8"	0500060
64.0	2-1/2"	0500064
65.0	2-9/16"	0500065
67.0	2-5/8"	0500067
68.0	2-11/16"	0500068
70.0	2-3/4"	0500070
73.0	2-7/8"	0500073



ALFRA – HSS-BI-METAL HOLE SAWS

Saw Ø mm	Inches	Prod.-No.
74.0	2-11/12"	0500074
76.0	3"	0500076
79.0	3-1/8"	0500079
83.0	3-1/4"	0500083
86.0	3-3/8"	0500086
89.0	3-1/2"	0500089
92.0	3-5/8"	0500092
95.0	3-3/4"	0500095
98.0	3-7/8"	0500098
102.0	4"	0500102
105.0	4-1/8"	0500105
108.0	4-1/4"	0500108
111.0	4-3/8"	0500111
114.0	4-1/2"	0500114
121.0	4-3/4"	0500121
127.0	5"	0500127
140.0	5-1/2"	0500140
152.0	6"	0500152

9.5 mm
3/8"

Prod.-No. 0501001 A6-SS

Prod.-No. 0501002 A6-SDS

Prod.-No. 0501003 A2-SS

Prod.-No. 0501005 A2-SDS

Prod.-No. 0501006 A3-SS



9.5 mm
3/8"

11.11 mm
7/16"

From Ø 160.0 mm only suitable for wood and wood substitutes.

160.0	6-5/16"	0500160
168.0	6-10/16"	0500168
177.0	7"	0500177
210.0	8-5/16"	0500210



Prod.-No. 0501013 with bi-metal hole saw Ø 68 mm + A2-SS

Arbors

with pilot drill

Saw-Ø mm	Saw-Ø inch	Type	Shank-Ø	Prod.-No.
14 - 30	9/16" - 1-3/16"	A 6-SS	9.5 hexagon	0501001
14 - 30	9/16" - 1-3/16"	A 6-SDS	SDS	0501002
32 - 152	1-1/4" - 6"	A 2-SS	9.5 hexagon	0501003
32 - 152	1-1/4" - 6"	A 2-SDS	SDS	0501005
32 - 210	1-1/4" - 8-5/16"	A 3-SS	11.11 hexagon	0501006
32 - 210	1-1/4" - 8-5/16"	A 5-SS	16.0 hexagon	0501008

Prod.-No. 0501013



Diverse applications

Accessories:

Rim countersink for Ø 68 mm (with TCT-teeth)	0501013
Extension shaft 300 mm x 9.5 mm for A 6-SS + A 2-SS, A3-SS	0501010
Spare Center Drill HSS Ø 6.35 mm x 80 mm for A 6-SS + A 6-SDS + A 2-SS + A 2-SDS + A 3-SS + A 5-SS	0502001
Ejector Spring	0502004

Prod.-No. 0501010

Prod.-No. 0502001

Prod.-No. 0502004

Important: Disable impact drill position when using SDS-shanks!

ALFRA – HSS-BI-METAL HOLE SAW SETS

HSS-Bi-Metal Hole Saw Sets



■ The following HSS-Bi-Metal Hole Saw Sets enlarge our range. These sets were especially compiled for electricians, mechanics, plumbers and for general, universal applications.

■ All sets are delivered in a robust and practical plastic case

■ Incl. Arbor A6-SS, Arbor A2-SS, Spare Twist Drill

■ These sets improve the presentation. Storage in solid tool cases.

Ø mm	16.0	19.0	22.0	24.0	25.0	29.0	32.0	35.0	38.0	44.0	51.0	52.0	57.0	64.0	67.0	68.0	76.0
Ø Inch	5/8"	3/4"	7/8"	15/16"	1"	1-1/8"	1-1/4"	1-3/8"	1-1/2"	1-3/4"	2"	2-1/16"	2-1/4"	2-1/2"	2-5/8"	2-11/16"	3"

Prod.-No.	Hole Saw Set Standard																
0503006	•	•	•			•		•		•		•	•		•		
Prod.-No.	Hole Saw Set Professional																
0503007	•	•	•		•	•	•	•	•	•	•			•			•
Prod.-No.	Hole Saw Set Electro																
0503008			•			•		•		•	•			•		•	
Prod.-No.	Hole Saw Set Sanitary																
0503009	•	•		•		•			•	•			•		•		

MULTI-STEP DRILLS – HSS DM O5

Application area:

The ideal tool for sheet metal forming, for the electrical industry, HVAC or the common engineering or the switchboard industry.

Suitable for all materials such as nonferrous metals, stainless steel sheets, thermoplastic and thermosetting plastics, as well as for steel sheets up to a max. material thickness of 6 mm.

With the Multi-Step Drills, sheet metals can be centered, drilled and subsequently deburred in one work step.

- A break of the drill tip mostly occurs through high feed forces at the start of the drilling operation. Multi-step drills with fixed drill tips are worthless then. A broken center drill in an ALFRA multi-step drill can be easily replaced. This more than compensates for the higher price.
- Each stage is equipped with a radially adjusted relief grinding corresponding to its diameter.
- Each stage is provided with an axial relief grinding and a relief angle on its cutting edge.
- All step diameters are laser marked on the tool.

Benefits of multi-step drills with keyway and 3 cutting edges:

- The keyway allows the drill to make a chipping cut during drilling for better chip removal.
- The special keyway geometry, arranged around the drill, makes for a longer cutting edge compared to the usual straight groove and noticeably easier cutting.
- Spiral cut chip spaces guarantee an absolute running smoothness and a high cutting capacity.

Tip:

The tool life can be considerably prolonged by using of ALFRA Cutting Spray or ALFRA Coolant Stick.

Advantages of TiAlN hard coating:

- Suitable for use on very hard materials (VA).
- Offers optimal tool life with the same use at the highest cutting speeds.
- Very high microhardness HV 0.05 of 3200 – so that the blue-black hard coating is more than 20% harder than conventional gold-yellow TiN coating.
- Maximum working temperature: 800°C.

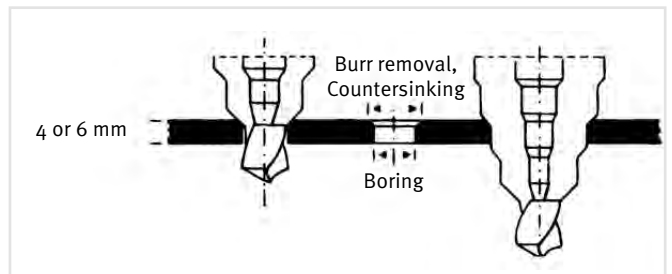

Descriptio	Shank Ø	Prod.-No.
Multi-Step Drill – AMS For general machine construction, drills circular holes in metals up to 4 mm thick, through application with hand drills, indispensable on the work-site. 3 chip spaces, spiral grooved, replaceable center drill Steps Ø 9 - 12 - 15 - 18 - 21 - 24 - 27 - 30 - 33 - 36 mm (Step "40" is for deburring)	10.0	08080

Multi-Step Drill – DKS 40 3 chip spaces, spiral grooved, replaceable center drill, for metric borings acc. to EN, Core - and clearance holes M 10 - M 40 Steps Ø 10.5 - 12.5 - 14.5 - 16.5 - 18.5 - 20.5 - 25.5 - 32.5 - 38.5 - 40.5	10.0	08084
---	------	-------



Prod.-No. 08080 ■



Prod.-No. 08084 ■

■ Exchangeable center drills

MULTI-STEP DRILLS – HSS DM O5

Standard execution with 2 chip spaces, spiral grooved.

- More precise hole diameter through cylindrical steps.
- Immediate deburring through the next step.
- Drilling of sheet metals as thin as 4 mm possible.
- Use coolant stick!
- The keyway allows the drill to make a chipping cut during drilling for better chip removal.
- Longer cutting edge compared to the usual straight groove and noticeably easier cutting.
- Laser-etched scale in the chip space to indicate the bore diameter achieved.

Descriptio	Bore range	Shank Ø	Length	Prod.-No.
AMS-30	6 - 30 mm x 2 mm	10.0	98 mm	08072

Multi-Step Drill – SVB	10.0	08016
Pre-drill specifically for punches & dies		
Steps Ø 8.5 - 11.5 - 12.5 - 16.5 - 21.0		



Prod.-No. 08072



Vorbohrer speziell für Blechlocher

Prod.-No. 08016

Standard values for the use of ALFRA Multi-step drills

This drill was developed to bore perfectly round and deburred holes in sheet metal from 4 - 6 mm thick. The transition forms a radius which serves to deburr or bevel the hole at the same time. While conical one-lip bits drill a slightly tapered hole, our ALFRA multi-step drill achieves a cylindrical hole. The tools have axial-radial relief grindings and can be lightly reground on the breast of the cutting tooth.

We recommend the use of pillar drilling machines, however, the small ALFRA Multi-step drills can be used on adjustable hand drilling machines. Sufficient cooling using **ALFRA coolant stick** or a bore emulsion is imperative.

R.P.M. Guiding Values					
Type		sheet steel S235	V2A sheets	non-ferrous metals	plastics soft
AM	drill	800	360	1000	1000
	counter-sink	500 - 180	50 - 70	800 - 400	1000 - 40

ALFRA SABRE SAW BLADES FOR PROFESSIONAL USE



ORIGINAL MILFORD SABRE SAW BLADES – EXKLUSIVE BY ALFRA

for Metal flexible version



Application Range Metal processing	Material thickness mm	Steel- Quality	Length	Width	Thickness	Teeth Inch	Milford Prod.-No.	Alfra Prod.-No.
Metal processing; soft metals, Copper-, aluminium-, brass-cables, wires and pipes	> 3 mm	HSS-Bi-Metal	100 mm	16 mm	0.9 mm	14	88161	30055
All kind of metals, stainless steel, Steel pipes, cast iron, alloys, etc.	> 6 mm	HSS-Bi-Metal	150 mm	16 mm	0.9 mm	10	88176	30058
All kind of metals, stainless steel, Steel pipes, cast iron, alloys, etc.	> 3 mm	HSS-Bi-Metal	150 mm	16 mm	0.9 mm	14	88177	30059
All kind of metals, stainless steel, Steel pipes, cast iron, alloys, etc.	> 1.15 mm	HSS-Bi-Metal	150 mm	16 mm	0.9 mm	18	88178	30060
All kind of metals, stainless steel, Steel pipes, cast iron, alloys, etc. With universal toothing	3-6 mm	HSS-Bi-Metal	150 mm	16 mm	0.9 mm	10/14	88216	30062
Metal processing; soft metals, Plastic, laminate and wood with nails	> 3 mm	HSS-Bi-Metal	225 mm	16 mm	0.9 mm	8/12	88219	30041
All kind of metals, stainless steel, Steel pipes, cast iron, alloys, etc.	> 6 mm	HSS-Bi-Metal	225 mm	16 mm	0.9 mm	10	88174	30063
All kind of metals, stainless steel, Steel pipes, cast iron, alloys, etc.	> 3 mm	HSS-Bi-Metal	225 mm	16 mm	0.9 mm	14	88186	30064
All kind of metals, stainless steel, Steel pipes, cast iron, alloys, etc.	> 1.15 mm	HSS-Bi-Metal	225 mm	16 mm	0.9 mm	18	88187	30065
All kind of metals, stainless steel, Steel pipes, cast iron, alloys, etc. With universal toothing	3-6 mm	HSS-Bi-Metal	225 mm	16 mm	0.9 mm	10/14	88217	30066
All kind of metals, stainless steel, Steel pipes, cast iron, alloys, etc. With universal toothing	> 6 mm	HSS-Bi-Metal	290 mm	16 mm	0.9 mm	10/14	88218	30072



Metal processing; soft metals, plastic, laminate an wood with nails – particular for pallets	> 3 mm	HSS-Bi-Metal	228 mm	19 mm	0.9 mm	10/14	88226	30045
--	--------	--------------	--------	-------	--------	-------	-------	-------

For Wood



Application Range Meta processing	Material	Steel-	Length	Width	Thickness	Teeth	Milford	Alfra
Special sabre saw for wood with nails; plasterboard In particular for the refurbishing	Wood, Plasterboard, Door	HSS-Bi-Metal	150 mm	19 mm	0.9 mm	5/8	88142	30085
Special sabre saw for wood Plastics or Laminates -curve sections-	Wood, Plasterboard, Door	HSS-Bi-Metal	150 mm	19 mm	0.9 mm	4/6	88143	30086
Special sabre saw for wood, plasterboard In particular for the refurbishing	Wood, Plasterboard, Door	HSS-Bi-Metal	210 mm	19 mm	0.9 mm	6	88144	30087
Special sabre saw for wood, plasterboard In particular for the refurbishing	Wood, Plasterboard, Door	HSS-Bi-Metal	290 mm	19 mm	0.9 mm	6	88145	30088

ALFRA PRESS

ALFRA-PRESS HYDRAULIC PUNCHES

Low-noise, fully automatic punching of steel beams and heavy metal plates

“Clack!” That’s all you hear when our hydraulic punches make round and slotted holes in steel beams or heavy metal plates in just one work step. The powerhouses APS 70 and APS 120 operate at 700 bar working pressure and get the job done in seconds.

And the best thing is that despite all this power, they are still mobile - for example, for use on your projects in steel and metal construction, bridge building or tank construction. The high-performance punches are perfect in a team with the right accessories.

- Strong in use on steel plates or beams up to 16 mm thick
- Available in jaw depths of 70 mm and 110 mm
- Unbeatable in team with our hydraulic pumps as drive
- Punches and dies from our own production
- Effortless positioning of the punches with the Serviceboy



ALFRA-PRESS HYDRAULIC PUNCHES – OVERVIEW



APS 70

Page	146
Prod.-No.	23002
Max. hole-Ø	22 mm 7/8"
Max. oblong hole	22 x 14 mm 7/8" x 9/16"
Max. material thickness (S235)	13 mm 1/2"
Overall punch time with pump ...	AHP-M: approx. 5 sec. AHP-L: approx. 3 sec.
Jaw depth	70 mm 2-3/4"
Max. pressure	700 bar 10,150 psi
Punching force	30 t
Punch stroke	18 mm 11/16"
Weight	29.9 kg / 65.9 lbs
Scope of delivery	Hose assembly 5 m/spanner Punch/die Ø 18 mm Depth adjustment, suspension bracket

HYDRAULIC PUMP FOR APS 70 / 120



AHP-M

Page	150 - 151
Prod.-No.	23189
Max. pressure	700 bar
Maximum pumping capacity:	1.1 l/min
Motor performance	1300 W, 230 v (50 Hz)
Fill volume	3.2 l
Weight incl. oil fill volume	29 kg



APS 120

147

23004

25 mm
1-1/16"

25 x 18 mm
1" x 11/16"

16 mm
5/8"

AHP-M: approx. 10 sec.
AHP-L: approx. 7 sec.

110 mm
4-3/8"

700 bar
10,150 psi

44 t

25 mm
15/16"

47.3 kg / 104.2 lbs

Hose assembly 5 m/spanner
Punch/die Ø 22 mm
Depth adjustment, suspension bracket

HYDRAULIC PUMP FOR APS 70 / 120



AHP-L

150 - 151

23190

700 bar

1.7 l/min

2,200 W, 230 v (50 Hz)

3.0 l

34 kg



ALFRA-PRESS – HYDRAULIC PUNCHING

ALFRA-Press - Hydraulic puncher APS 70

Prod.-No.
23002

Hydraulic punching unit with
Automatic return using neoprene spring

Technical specifications:

Max. hole Ø mm	22 mm
Max. oblong hole	22 x 14 mm
Max. material thickness as per DIN S275	13 mm
Total punch time with pump AHP-M	5 sec.
with pump AHP-L	3 sec.
Jaw depth	70 mm
Max. pressure	700 bar (10,150 psi)
Punching force	30 t
Punching stroke	18 mm
Weight	29.9 kg

Scope of delivery:

Punching unit, control cable, hydraulic hose 5 m, spanner,
1 x punch and die each Ø 18 mm, 1 depth adjustment, 1 suspension bracket



Prod.-No. 23002



VIDEO

Accessories

Prod.-No.

Replacement HP connection hose, **5 m**
complete with control cable and coupling

23015

Replacement HP connection hose, **10 m**
complete with control cable and coupling

23016

Replacement HP connection hose, ***15 m**
complete with control cable and coupling

23017

*Note:

The pressure build-up extends at 10 m to approx. 4 sec., and at 15 m to approx. 6 sec.

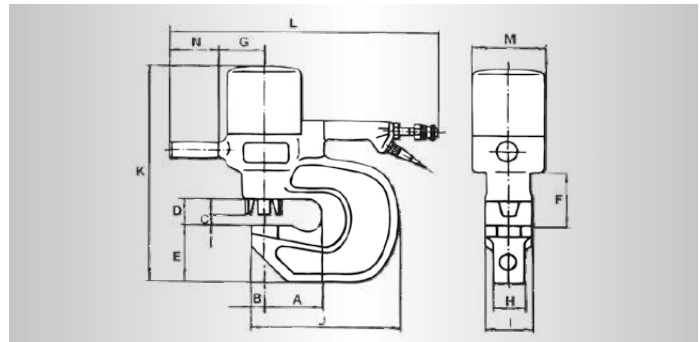

Important technical note:

Standard punching units are not normally suitable for punching high strength tooling steel, stainless steels or boiler-plate steel. Refer to us for technical advice for punching work in this application range.

Type	A	B	C	D	E	F	G	H	I	J	K	L	M	N
APS 70	70	24	15	51	85	100	80	40	80	204	382	562	125	135
APS 120	110	25	18	51	111	110	90	68	100	285	442	585	144	135

ALFRA-Press - Hydraulic puncher APS 120

Hydraulic punching unit with
Automatic return using neoprene spring

Prod.-No.
23004

Technical specifications

Max. hole Ø mm	25 mm
Max. oblong hole	25 x 18 mm
Max. material thickness as per DIN S275	16 mm
Total punch time with pump AHP-M	10 sec.
with pump AHP-L	7 sec.
Jaw depth	110 mm
Max. pressure	700 bar (10,150 psi)
Punching force	44 t
Punching stroke	25 mm
Weight`	47.3 kg

Scope of delivery:

Punching unit, control cable, hydraulic hose 5 m, spanner,
1 x punch and die each Ø 22 mm, 1 depth adjustment, 1 suspension
bracket



Prod.-No. 23004

Accessories

Replacement HP connection hose, **5 m**
complete with control cable and coupling

Prod.-No.
23015

Replacement HP connection hose, **10 m**
complete with control cable and coupling

23016

Replacement HP connection hose, ***15 m**
complete with control cable and coupling

23017

*Note:

The pressure build-up extends at 10 m to approx. 4 sec., and at 15 m to
approx. 6 sec.



ALFRA – APS PUNCHES AND DIES



Punch for



Dies for

APS 120	APS 70	Ø mm	Prod.-No.	APS 120	APS 70	Ø mm	Prod.-No.
■	■	7	23-01-07	■	■	7	23-02-07
■	■	8	23-01-08	■	■	8	23-02-08
■	■	9	23-01-09	■	■	9	23-02-09
■	■	10	23-01-10	■	■	10	23-02-10
■	■	11	23-01-11	■	■	11	23-02-11
■	■	12	23-01-12	■	■	12	23-02-12
■	■	13	23-01-13	■	■	13	23-02-13
■	■	14	23-01-14	■	■	14	23-02-14
■	■	15	23-01-15	■	■	15	23-02-15
■	■	16	23-01-16	■	■	16	23-02-16
■	■	17	23-01-17	■	■	17	23-02-17
■	■	18	23-01-18	■	■	18	23-02-18
■	■	19	23-01-19	■	■	19	23-02-19
■	■	20	23-01-20	■	■	20	23-02-20
■	■	21	23-01-21	■	■	21	23-02-21
■	■	22	23-01-22	■	■	22	23-02-22
■	-	23	23-01-23	■	-	23	23-02-23
■	-	24	23-01-24	■	-	24	23-02-24
■	-	25*	23-01-25	■	-	25*	23-02-25

*) with lock nut, Prod.-No. 23004-056 B

When selecting your tool, please note:

For material DIN S233: maximum material thickness = 0.8 x hole Ø

For material DIN S275: maximum material thickness = 0.5 x hole Ø



Prod.-No. 23-01-..

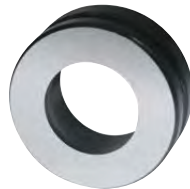

Prod.-No. 23-02-..



Tip:

Punches and dies can be replaced and used for Nitto / Selfer Punching systems.

Tip:

Please oil punch from time to time, when material is heavily oxidized.

ALFRA – APS PUNCHES AND DIES

5°-bevelled dies for

APS 120	APS 70	Ø mm	Prod.-No.
■	■	10	23-04-10
■	■	11	23-04-11
■	■	12	23-04-12
■	■	13	23-04-13
■	■	14	23-04-14
■	■	15	23-04-15
■	■	16	23-04-16
■	■	17	23-04-17
■	■	18	23-04-18
■	■	19	23-04-19
■	■	20	23-04-20
■	■	21	23-04-21
■	■	22	23-04-22
■	-	23	23-04-23
■	-	24	23-04-24
■	-	25	23-04-25



Prod.-No. 23-04-... (For carriers with angled flange)

Oblong punches for

mm	APS 120	APS 70	Punch Prod.-No.	Die Prod.-No.
16 x 8	■	■	23-01-1608	23-02-1608
18 x 9	■	■	23-01-1809	23-02-1809
18 x 11	■	■	23-01-1811	23-02-1811
20 x 10	■	■	23-01-2010	23-02-2010
20 x 12	■	■	23-01-2012	23-02-2012
20 x 14	■	■	23-01-2014	23-02-2014
22 x 11	■	■	23-01-2211	23-02-2211
22 x 14	■	■	23-01-2214	23-02-2214
24 x 12	■	-	23-01-2412	23-02-2412
25 x 9*	■	-	23-01-2509	23-02-2509
25 x 12*	■	-	23-01-2512	23-02-2512
25 x 13*	■	-	23-01-2513	23-02-2513
25 x 14*	■	-	23-01-2514	23-02-2514
25 x 18*	■	-	23-01-2518	23-02-2518



Prod.-No. 23-02-..



Prod.-No. 23-01-..

*) with lock nut, Prod.-No. 23004-56B

Replacement parts

	Prod.-No.
Lock nut for punch Ø 7 - 24 mm	23004-056A
Lock nut for punch Ø 25 mm (only APS 120)	23004-056B



Prod.-No. 23004-056A
For punches Ø 7 - 24 mm



Prod.-No. 23004-056B
For punches Ø 25 mm

ALFRA ELECTRIC HYDRAULIC PUMPS

- 1 Powerful, hydraulic drive unit for maximum punching performance and speed
- 2 Additional fan allows continuous use - even in warmer regions
- 3 Light housing made of impact-resistant plastic
- 4 Extra large, non-slip carrying handles on which the power cord can be wrapped
- 5 Extremely space-saving thanks to compact design



ALFRA ELECTRIC HYDRAULIC PUMP AHP-M



Technical specifications:

Max. pressure:	700 bar
Max. pumping capacity:	1.1 l/min
Oil type:	HLP 46
Fill volume:	3.2 l
Active volume:	2.2 l
Weight:	29 kg
Operating voltage:	230 V / 50 Hz
Rating:	1.3 kW
Power consumption:	5.65 A
Motor speed:	2800 1/min

Electric hydraulic pump AHP M

Prod.-No.

23189

ALFRA ELECTRIC HYDRAULIC PUMP AHP-L



Technical specifications:

Max. pressure:	700 bar
Max. pumping capacity:	1.7 l/min
Oil type:	HLP 46
Fill volume:	3.0 l
Active volume:	2.2 l
Weight:	34 kg
Voltage, frequency:	230 V / 50 Hz
Rating:	2.2 kW
Power consumption:	9.8 A
Motor speed:	2860 1/min

Electric hydraulic pump AHP L

Prod.-No.

23190

Not available in 110V

SERVICE-BOY

For hydraulic punching units APS of all types

This practical, time and energy-saving trolley makes handling of our ALFRA Press hydraulic punching units much easier. Absolutely necessary for every steel and metal worker wherever punching units are already in use.

- * Gas pressure shock absorbers allow the easy positioning of the punching head on the steel bar
- * The hydraulic pump remains on the trolley, and must not be dragged along behind you
- * Work tool cabinet with drawers for the clear arrangement of punching work tools and accessories
- * Solid and secure – and more cost-effective than any "DIY-build"
- * Dimensions (L x W x H): 900 x 520 x 1,970 mm

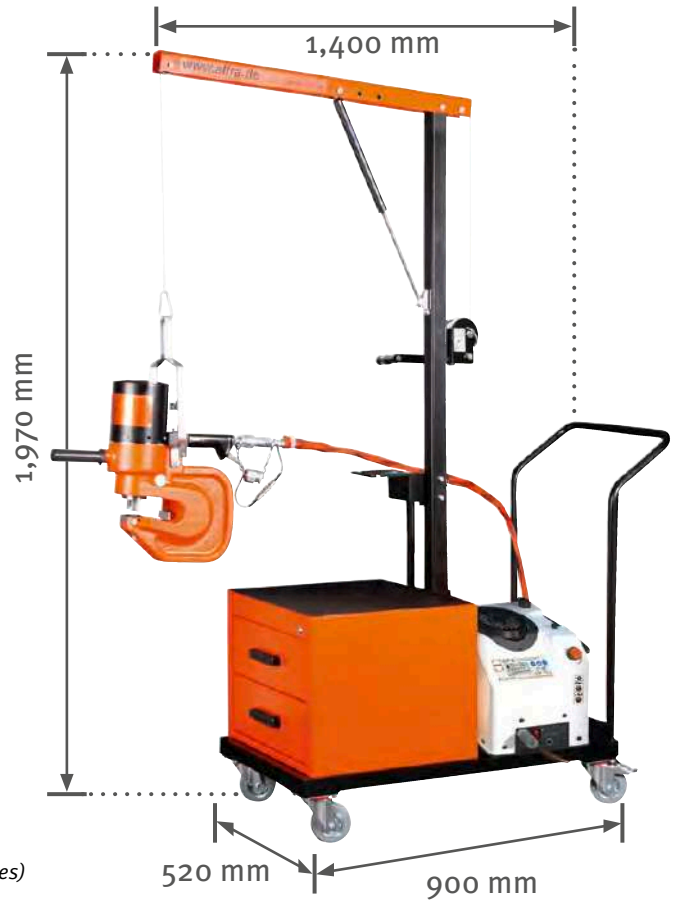

Service-Boy
Complete with tool cabinet and drawers

Prod.-No.
23160

Prod.-No. 23160 (without punching unit / pump + accessories)



APS GO

For all types of APS hydraulic punching units

APS GO enables you to easily move our punching units over the steel bar

An adapter plate connects the punching unit to the moving system, and allows this to be removed at any time.

This generates enormous time savings, especially when punching at identical space intervals, as the measurement needs only to be set once, and the interval lengths are easy to measure.

Massive, solid heavy-duty rollers and the side-mounted hand grips enable completely effortless movement over the steel bar.

Dimensions (L x W x H): 700 x 355 x 280 mm
Weight: 14 kg / 30.8 lbs

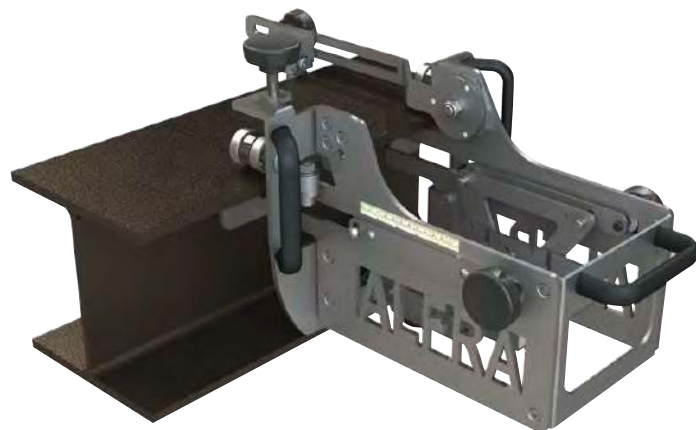

APS Go

Prod.-No.
23155



APPLICATION SOLUTIONS FOR MAGNETICS AND LIFTING TECHNOLOGY



LIFTING

Holds! Our lifting magnets don't let up

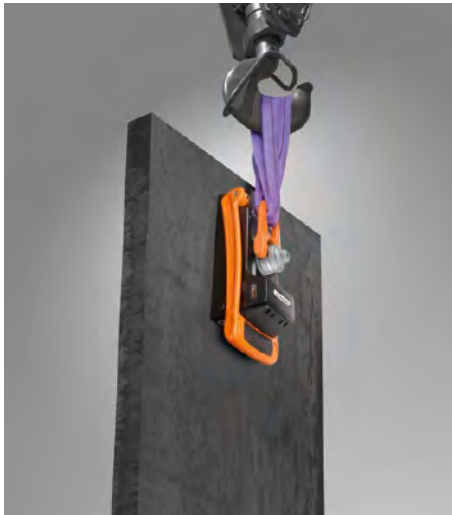

“Keeping at it” is the motto for lifting magnets from Alfra’s law – Whether for round or flat steel. Depending on the model, the reliable helpers lift up to one tonne of ferromagnetic material. Thanks to patented TML technology depending on the product even on thin-walled sheets fittings from one millimetre in thickness.

- Magnetic field with very low scattering losses develops impressive holding power even on thin materials.
- Safety factor 3:1
- Can be customised for a wide variety of projects individually thanks to additional threaded
- Prism for safe lifting of pipes and curved surfaces



**MADE IN
GERMANY**

POSITIONING AND FIXING

As you were! Holding magnets and welding angle for fixing and levelling



Could you also regularly use a helping hand with your projects? No matter whether steel plates for welding onto kept at the same height or whether steel beams or pipes are to be joined at a specific angle by welding seam – arc created during welding – there is certainly a magnet in our range that can master this task.

- Angle magnet TMA 600 for aligning heavy workpieces at different angles
- Infinitely adjustable from 0° to 90°
- Welding seams are possible close to the magnet because the arc created is only deflected in our range that can master this when a distance of less than 15 mm to the tool is reached.
- Connection threads in M5 and M6 on the surface and on both sides of the housing for the possibility of customising the Alfa holding solenoids from the TMC line in a variety of ways

ALFRA MAGNETS IN ACTION



HALLENBAU – USA / BLOOMFIELD – RICARDO

Thin Material Lifting explained simply
Watch our animated video here



VIDEO



SHIPBUILDING – TURKU / FINLAND – ALEKSI



LIFTING – RECIFE / BRAZIL – PEDRO



“The Alfra SPV is a real asset. In addition to the precision made possible by its use, the drill stand also brings a considerable gain in safety for the user, because jerking and jamming machines are now a thing of the past... Thanks to permanent magnets, a secure hold of the SPV is guaranteed for many years without follow-up costs.”



PDF

Jörg Ueltkesforth
Technical editor, Motor & Maschine 3/2018

TML – THE BENEFITS AT A GLANCE

In which way do ALFRA TML Magnets stand out from conventional magnets?

Graph A – The TML provides more performance!

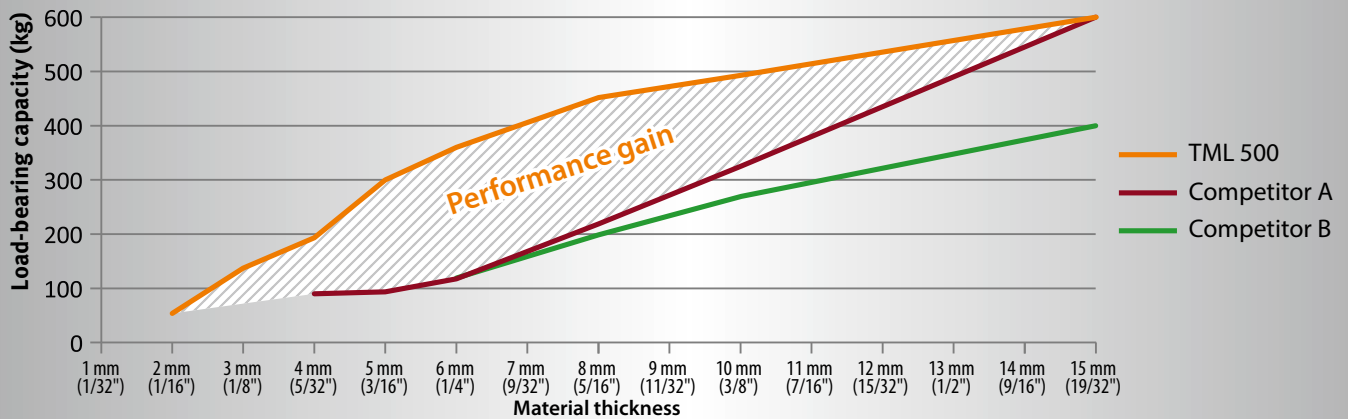

A comparison of the performance data of the TML 500 and two conventional magnets reveals how powerful the TML 500 is, especially when used on thin materials.

The hatched area shows the 'performance gain' of the TML and illustrates how big the performance difference is between TML and conventional magnets.

The measurements were taken on thin-walled steel S235 by means of a pull-off station certified by the TÜV (German Technical Inspection Association).

The result: Whereas competitors A and B are not able to generate a sufficient magnetic field on thin materials, the TML achieves a load-bearing capacity of 50 kg (110 lbs) on just 2 mm (1/16") and 195 kg (430 lbs) on 4 mm (5/32") material thickness – this is unique to ALFRA.

Graph B – Less weight but more performance!

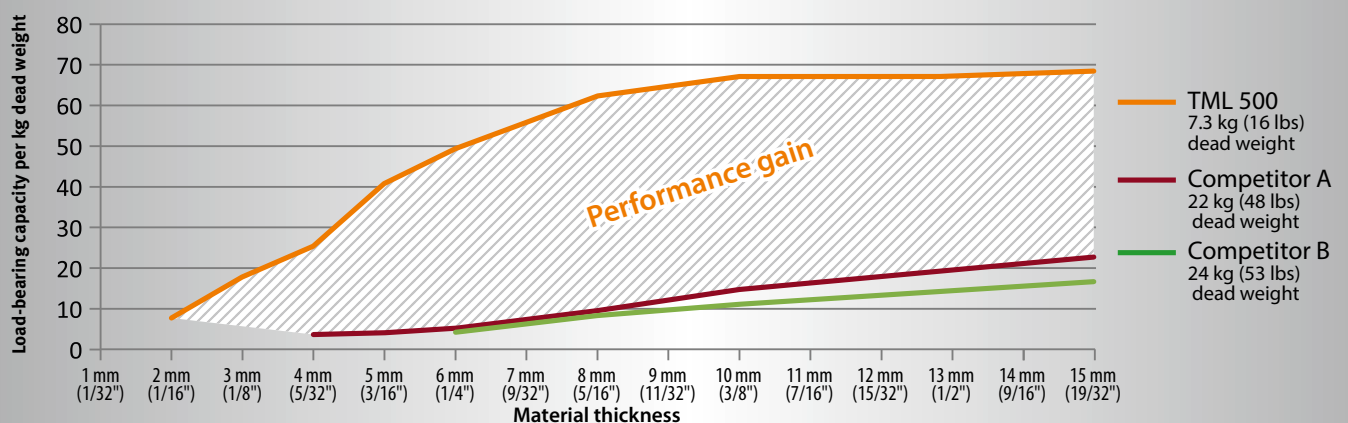

When taking the ratio of the magnets' load capacity in graph A and their dead weight into account, the hatched 'performance gain' shows the efficiency of TML magnets in contrast to their competitors.

Conventional lifting magnets exhibit lower performance due to their extremely high dead weight and their relatively low adhesive force. The TML, however, weighs just a fraction of the weight of competitors A and B while achieving a considerably higher load-bearing capacity.

TML Lifting Magnets—the ideal tools to lift thin materials with thicknesses as low as 2 mm (1/16")!

FURTHER BENEFITS OF THE ALFRA MAGNETIC SYSTEM



Hardened steel bottom plate with TiN-coating eliminating the need to regrind the magnet's bottom plate: reduced maintenance



Slight premagnetisation for the easy positioning of the magnet



One-handed activation possible

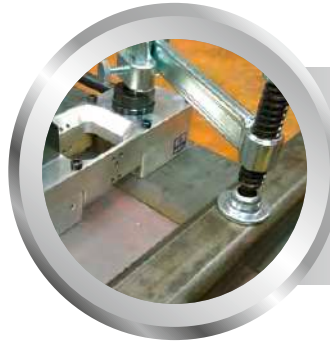

Magnets can be customized thanks to additional connection threads inside the housing



New design allowing for the use of the magnet even between the flanges of a steel beam



The magnetic field concentrates directly on the material and reduces scattering losses to a minimum



180° pivotable and 360° rotatable load swivel



Magnets allow welding at a distance of just 15 mm (9/16") from the magnet's external side

ALFRA MAGNET TECHNOLOGY



LIFTING



CORE DRILLING

ALFRA sets new standards in magnet technology!

Our Permanent Magnets are activated according to a patented principle, completely independent of the mains supply—providing safety and permanent stability!

ALFRA is the worldwide license holder for the new, patented magnetic system that allows you to drill, lift, position, transport...from a material thickness of just 1 mm (1/32")!



POSITIONING



US Patent No.
8350663B1



SPECIAL / PROBLEM SOLUTIONS

MAGNETIC AND LIFTING TECHNOLOGY - OVERVIEW

LOAD-LIFTING - FLAT STEEL

 KG LBS					
	50 KG (110 LBS)	100 KG (220 LBS)	250 KG (550 LBS)	500 KG (1,100 LBS)	1,000 KG (2,200 LBS)
					
	TMH 50	TML 100	TML 250	TML 500	TML 1000
Page	162	163	164 - 165	166 - 167	168 - 169
Prod.-No.	41100.H	41100.L	41250	41500	41700
Max. load-bearing capacity	50 kg (110 lbs)	100 kg (220 lbs)	250 kg (550 lbs)	500 kg (1,100 lb)	1,000 kg (2,200 lbs)
Breakaway force	> 300 kg (660 lbs) on 6 mm (1/4") steel S235 (without adapter plate)	> 300 kg (660 lbs) on 6 mm (1/4") steel S235	> 750 kg (1,653 lbs) on 10 mm (3/8") steel S235	> 1,500 kg (3,300 lbs) on 15 mm (9/16") steel S235	3,400 kg (7,500 lbs) on 12 mm (1/2") steel S235
Min. material thickness	1 mm (1/32")	1 mm (1/32")	2 mm (1/16")	2 mm (1/16")	2 mm (1/16")
Dead weight	1.6 kg (3.5 lbs)	1.7 kg (3.7 lbs)	3.5 kg (7.7 lbs)	7.3 kg (16 lbs)	18.0 kg (238 lbs)
Dimensions L x W (closed lever)	190 x 124 mm (7 1/2" x 4 7/8")	146 x 124 mm (5 3/4" x 4 7/8")	240 x 91 mm (9 7/16" x 3 9/16")	295 x 118 mm (11 5/8" x 4 5/8")	470 x 154 mm (18 1/2" x 6 1/16")

LOAD-LIFTING - ROUND STEEL

 KG LBS			
	50 KG (110 LBS)	100 KG (220 LBS)	400 KG (880 LBS)
			
	TMH 50 R	TML 90 R	TML 400 R
Page	170	171	172 - 173
Prod.-No.	41100.H.R	41100.L.R	41400.R
Pipe diameter	25 - 200 mm (1" - 7-7/8")	25 - 200 mm (1" - 7-7/8")	50 - 400 mm (2" - 15-3/4")
Max. load-bearing capacity	50 kg* (110 lbs)*	100 kg* (200 lbs)*	400 kg* (880 lbs)*
Breakaway force	> 270 kg (595 lbs) on 6 mm (1/4") steel S235	> 270 kg (595 lbs) on 6 mm (1/4") steel S235	> 1,200 kg (2,650 lbs) on 15 mm (9/16") S235
Min. material thickness	1 mm (1/32")	1 mm (1/32")	2 mm (1/16")
Dead weight	1.6 kg (3.5 lbs)	1.8 kg (4 lbs)	8.2 kg (18 lbs)
Dimensions L x W (closed lever)	190 x 124 mm (7 1/2" x 4 7/8")	146 x 124 mm (5 3/4" x 4 7/8")	295 x 118 mm (11 5/8" x 4 5/8")

*Max. load-bearing capacity on round pipes: 20 - 50 % of flat material subject to pipe diameter and material thickness

SPECIAL SOLUTIONS

	POSITIONING/ INDIVIDUALIZATION			ANGLE FIXING
	FOR FLAT STEEL		FOR ROUND STEEL	0° - 90°
				
	TMC 70	TMC 300	TMC 300 R	TMA 600
Page	174	175	176	177
Prod.-No.	41070	41100	41100.R	41100.A
Pipe diameter	-	-	25 - 200 mm (1" x 7-7/8")	-
Holding force	70 kg (155 lbs)	300 kg (660 lbs)	300 kg (660 lbs)	2 x 300 kg (2 x 660 lbs)
Breakaway force	> 72 kg (158 lbs) on 6 mm (1/4") steel S235	> 300 kg (660 lbs) on 6 mm (1/4") steel S235	> 300 kg (660 lbs) on 6 mm (1/4") steel S235	> 300 kg (660 lbs) each TMC 300 on 6 mm (1/4") steel S235
Min. material thickness	1 mm (1/32")	1 mm (1/32")	1 mm (1/32")	1 mm (1/32")
Dead weight	0.29 kg (63 lbs)	1 kg (2.2 lbs)	1.1 kg (2.4 lbs)	2.7 kg (6 lbs)
Dimensions L x W (closed lever)	65 x 50 mm (2 3/4" x 2")	146 x 124 mm (5 3/4" x 4 7/8")	146 x 124 mm (5 3/4" x 4 7/8")	249 x 180 mm (9 13/16" x 7 1/16") (with levers, magnets are parallel)

MANUAL LIFTING MAGNET TMH 50

- 1 Only 1.6 kg (3.5 lbs) dead weight
- 2 Large, stable handle



- Up to 50 kg (110 lbs) load-bearing capacity on a steel sheet S235 with a thickness of just 3 mm (1/8")
- Protects hands and fingers from hot and sharp-edged steel
- Indispensable for anyone who, e.g. has to transport welding-parts from A to B without a lifting device. (Max. temperature 60° C; 140°F)
- Wear-resistant magnetic contact area made of hardened steel with TiN-coating preventing damages and guaranteeing a long lifetime

Technical data TMH 50:

- Dead weight: 1.6 kg (3.5 lbs)
- Breakaway force: > 300 kg (660 lbs) on 6 mm (1/4") steel S235 (without adapter plate)
- Max. load-bearing capacity on flat material: 50 kg (110 lbs) (on 3 mm; 1/8" steel S235)
- Max. load-bearing capacity during vertical lifts: 35 kg (77 lbs) (on 3 mm; 1/8" steel S235)
- Length: 126 mm (4-15/16"); width: 80 mm (3-1/8"); height: 100 mm (3-15/16") (incl. lever: length 190 mm; 7-1/2", width 124 mm; 4-7/8")



VIDEO

Prod.-No.

41100.H

ALFRA TMH 50

LIFTING MAGNET TML 100

- 1 Only 1.7 kg (3.7 lbs) dead weight
- 2 Max. load-bearing capacity: 100 kg (220 lbs) (with 3:1 safety factor)
- 3 360° rotatable and 180° pivotable load swivel
- 4 Easy one-handed operation



- Max. load-bearing capacity of 50 kg (110 lbs) with 3 mm (1/8") (material thickness and 100 kg load-bearing capacity from just 6 mm (plus triple safety factor)
- Outstanding performance on thin-walled materials (operable from just 1 mm; 1/32")
- 360° rotatable and 180° pivotable load swivel – even under full load
- Wear-resistant magnetic contact area made of hardened steel with TiN-coating preventing damages and guaranteeing a long lifetime

Technical data TML 100:

- Dead weight: 1.7 kg (3.7 lbs)
- Breakaway force: > 300 kg (660 lbs) on 6 mm (1/4") steel S235
- Max. load-bearing capacity during vertical lifts (90° inclination of the load): 30 kg (66 lbs) (from 6 mm ; 1/4" steel S235 with 3:1 safety factor)
- Length: 82.5 mm (3-1/4"); width: 80 mm (3-1/8");
(incl. lever: length 190 mm; 7-1/2", width 124 mm; 4-7/8")
height (load swivel in horizontal position): 85 mm (3-3/8"),
height (load swivel in vertical position): 147 mm (5-13/16")

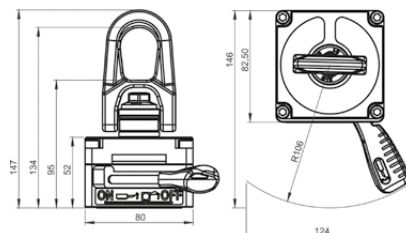

VIDEO

Prod.-No.

41100.L

ALFRA TML 100



MAGNETIC
SYSTEMS
PATENTED
US Patent No.
8350663B1

Empfehlung
PROFESSIONAL 3/22
Tools

Alfra Lasthebemagnet TML 250
Art.-Nr.: 41250

Oberklasse 1,2

PROFESSIONAL 3/22
Tools

Preis/Leistung: gut – sehr gut

Top class! Our TML 250 receives a recommendation from the test magazine „Professional Tools“: Easy to use, easy to transport, good to very good price-performance ratio.



 **WEB**

LIFTING MAGNET TML 250

- 1 Only 3.5 kg (7.7 lbs) dead weight
- 2 Max. load-bearing capacity: 250 kg (550 lbs) (with 3:1 safety factor)
- 3 360° rotatable and 180° pivotable load swivel
- 4 One-handed operation ('inside' steel beam possible)



- Up to 250 kg (550 lbs) load-bearing capacity from a material thickness of 10 mm (3/8") and 90 kg (195 lbs) from just 3 mm (1/8") material thickness on steel S235 plus 3:1 safety factor (i.e. the force that leads to the breakaway of the metal sheet must represent triple the maximum holding force)
- Outstanding performance on thin-walled materials
- Up to 70 % less dead weight with at least the same performance in contrast to conventional magnets
- Easy activation with minimal effort due to the ergonomic activation lever
- Innovative operational concept allowing for an enlarged operating range
- 360° rotatable and 180° pivotable load swivel
- Wear-resistant magnetic contact area made of hardened steel with TiN-coating preventing damages and guaranteeing a long lifetime

Technical data TML 250:

- Dead weight: 3.5 kg (7.7 lbs)
- Breakaway force: > 750 kg (1,653 lbs) on 10 mm (3/8") steel S235
- Max. load-bearing capacity: 250 kg (550 lbs) (with 3:1 safety factor)
- Length: 240 mm (9-7/16") (closed lever), width: 91 mm (3-9/16"), height: 191 mm (7-1/2") (opened lever)
- Magnetic contact area: length: 135 mm (5-5/16"), width: 65 mm (2-9/16")

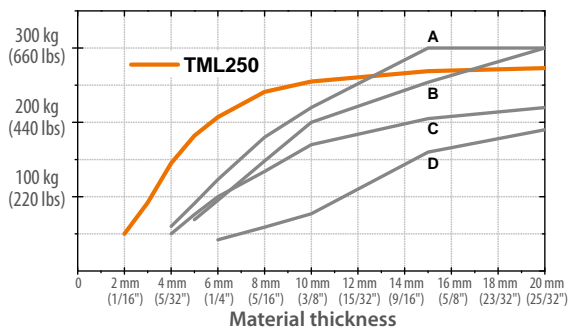

Competitors:

- A: 300 kg (660 lbs) Permanent magnet; 9 kg (19.8 lbs) Dead weight
- B: 300 kg (660 lbs) Permanent magnet; 11 kg (24.2 lbs) Dead weight
- C: 250 kg (550 lbs) Permanent magnet; 10 kg (22 lbs) Dead weight
- D: 250 kg (550 lbs) Permanent magnet; 10 kg (22 lbs) Dead weight

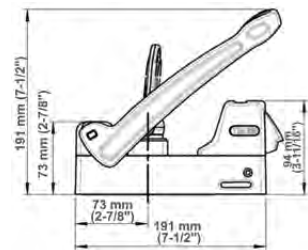

Prod.-No.

ALFRA TML 250

41250



**MAGNETIC
SYSTEMS**

PATENTED

US Patent No.
8350663B1

LIFTING MAGNET TML 500

- 1 Only 7.3 kg (16 lbs) dead weight
- 2 Max. load-bearing capacity: 500 kg (1,100 lb) (with 3:1 safety factor)
- 3 360° rotatable and 180° pivotable load swivel
- 4 One-handed operation ('inside' steel beam possible)



MADE IN GERMANY
 US Patent No. 8350663B1

- Up to 490 kg (1100 lbs) load-bearing capacity from a material thickness of 10 mm (3/8") and 300 kg (660 lbs) from just 5 mm (3/16") material thickness on steel S235 plus 3:1 safety factor (i.e. the force which leads to the breakaway of the metal sheet must represent triple the maximum holding force)
- Outstanding performance on thin-walled materials (useable from as low as 2 mm; 1/16")
- Up to 70 % less dead weight with at least the same performance in contrast to conventional magnets
- Easy activation with minimal effort due to the ergonomic activation lever
- Innovative operational concept allowing for an enlarged operating range
- 360° rotatable and 180° pivotable load swivel
- Wear-resistant magnetic contact area made of hardened steel with TiN-coating preventing damages and guaranteeing a long lifetime

Technical data TML 500:

- Dead weight: 7.3 kg (16 lbs)
- Breakaway force: > 1,500 kg (3,300 lbs) on 15 mm (9/16") steel S235
- Max. load-bearing capacity: 500 kg (1,100 lb) (with 3:1 safety factor)
- Max. load-bearing capacity during vertical lifts (90° inclination of the load): 150 kg (330 lbs) (from 15 mm; 9/16" on steel S235 with 3:1 safety factor)
- Length: 295 mm (11-5/8") (closed lever), width: 118 mm (4-5/8"), height: 216 mm (8-1/2") (opened lever)
- Magnetic contact area: length: 185 mm (7-1/4"), width: 88 mm (3-7/16")

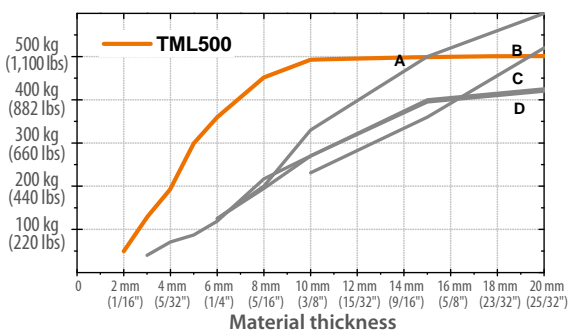

Competitors:

- A:** 600 kg (1,320 lbs) Permanent magnet; 22 kg (48.5 lbs) Dead weight
- B:** 600 kg (1,320 lbs) Permanent magnet; 24 kg (52.9 lbs) Dead weight
- C:** 500 kg (1,100 lbs) Permanent magnet; 20 kg (44 lbs) Dead weight
- D:** 500 kg (1,100 lbs) Permanent magnet; 8 kg (17.6 lbs) Dead weight

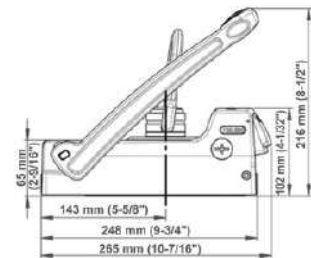

ALFRA TML 500

Prod.-No.

41500

**MAGNETIC
SYSTEMS**
PATENTED
US Patent Nr.
8350663B1



▶ VIDEO

LIFTING MAGNET TML 1000

- 1 Only 18.0 kg (40 lbs) dead weight
- 2 Max. load-bearing capacity: 1.000 kg (2,200 lbs) (with 3:1 safety factor)
- 3 360° rotatable and 180° pivotable load swivel
- 4 One-handed operation ('inside' steel beam possible)



- Up to 1,000 kg (2,200 lbs) load-bearing capacity from a material thickness of 10 mm (3/8") on steel S235 plus 3:1 safety factor (i.e. the force which leads to the breakaway of the metal sheet must represent triple the maximum holding force)
- Outstanding performance on thin-walled materials (useable from as low as 2 mm; 1/16")
- Up to 70 % less dead weight with at least the same performance in contrast to conventional magnets
- Easy activation with minimal effort due to the ergonomic activation lever
- Innovative operational concept allowing for an enlarged operating range
- 360° rotatable and 180° pivotable load swivel
- Wear-resistant magnetic contact area made of hardened steel with TiN-coating preventing damages and guaranteeing a long lifetime

Technical data TML 1000:

- Dead weight: 18.0 kg (40 lbs)
- Breakaway force: > 3,400 kg (7,500 lbs) on 12 mm (1/2") steel S235
- Max. load-bearing capacity: 1,000 kg (2,200 lbs) (with 3:1 safety factor)
- Max. load-bearing capacity during vertical lifts (90° inclination of the load): 300 kg (660 lbs) (from 12 mm; 15/32" on steel S235 with 3:1 safety factor)
- Length: 470 mm (18-1/2") (closed lever), width: 154 mm (6-1/16"), height: 335 mm (13-3/16") (opened lever)
- Magnetic contact area: Length: 387 mm (15-1/4"), width: 92 mm (3-5/8")

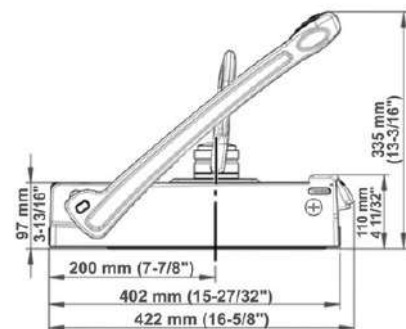

Prod.-No.

ALFRA TML 1000

41700

MANUAL LIFTING MAGNET TMH 50 R

1 Only 1.6 kg (3.5 lbs) dead weight

2 Large, stable handle

R With prism for pipes and curved surfaces
Lifts pipes from 25 mm (1") to 200 mm (7-7/8") in diameter



- Lifts pipes from 25 mm (1") to 200 mm (7-7/8") in diameter
- Protects hands and fingers from hot and sharp-edged steel
- A must have for everyone who needs to move welding parts from one place to another (max. temperature: 60°C; 140°F)
- Wear-resistant magnetic contact area made of hardened steel with TiN-coating preventing damages and guaranteeing a long lifetime

Technical data TMH 50 R:

- Dead weight: 1.6 kg (3.5 lbs)
- Breakaway force: > 270 kg (660 lbs) on 6 mm; 1/4" steel S235
- Max. load-bearing capacity on round pipes: 20 - 50 % of flat material (see TMH 50), subject to pipe diameter and material thickness
- Length: 126 mm (4-15/16"); width: 80 mm (3-1/8"); height: 100 mm (3-15/16") (incl. lever: length 190 mm; 7-1/2", width 124 mm; 4-7/8")



ALFRA TMH 50 R

Prod.-No.
41100.H.R

LIFTING MAGNET TML 90 R

R With prism for pipes and curved surfaces
Lifts pipes 25 mm (1") to 200 mm (7-7/8") in diameter

- 1 Only 1.8 kg (4 lbs) dead weight
- 2 Max. load-bearing capacity: 100 kg (220 lbs) (with 3:1 safety factor)
- 3 360° rotatable and 180° pivotable load swivel
- 4 Easy one-handed operation



- Lifts pipes from 25 mm (1") to 200 mm (7-7/8") in diameter
- Outstanding performance on thin-walled materials (operable from just 1 mm; 1/32")
- 360° rotatable and 180° pivotable load swivel – even under full load
- Wear-resistant magnetic contact area made of hardened steel with TiN-coating preventing damages and guaranteeing a long lifetime

Technical data TML 90 R:

- Dead weight: 1.8 kg (4 lbs)
- Breakaway force: > 270 kg (595 lbs) on 6 mm (1/4") steel S 235
- Max. load-bearing capacity with round pipes: 20 - 50 % of the load-bearing capacity on flat material (see TML 100), depending on pipe diameter and material thickness
- Length: 82.5 mm (3-1/4"); width: 80 mm (3-1/8");
(incl. lever: length 190 mm; 7-1/2", width 124 mm; 4-7/8")
height (load swivel in horizontal position): 88 mm (3-7/16")
height (load swivel in vertical position): 150 mm (5-15/16")

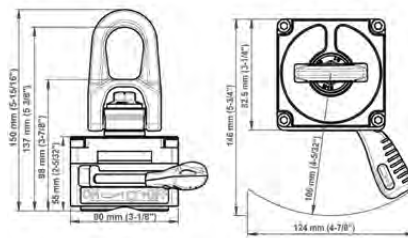

VIDEO

Prod.-No.

41100.L.R

ALFRA TML 90 R



“In metalworking companies or on construction sites, time pressure and high safety standards play an important role. With the TML 400 R magnet from Alfra, our customers not only lift and adjust up to 400 kg with a safety factor of 3:1, but thanks to the 360° swivelling and rotating load whirl, the permanent magnet with one-hand operation function transports round steel from A to B in an uncomplicated way: for example, pipes in pipeline construction, curved sheets in container construction, or round workpieces when loading metalworking machines...”

Ferry Plattes
Technical Representative -
Sales Support
Lifteurop



▶ VIDEO



LIFTING MAGNET TML 400 R

R With prism for pipes and curved surfaces
Lifts pipes from 50 mm (2") to 400 mm (15-3/4") in diameter

- 1 Only 8.2 kg (18 lbs) dead weight
- 2 Max. load-bearing capacity: 400 kg (880 lbs) (with 3:1 safety factor)
- 3 360° rotatable and 180° pivotable load swivel
- 4 Easy one-handed operation



- Lifts pipes from 50 mm (2") to 400 mm (15-3/4") in diameter
- Outstanding performance on thin-walled materials (operable from just 2 mm; 1/16")
- 360° rotatable and 180° pivotable load swivel—even under full load
- Wear-resistant magnetic contact area made of hardened steel with TiN-coating preventing damages and guaranteeing a long lifetime

Technical data TML 400 R:

- Dead weight: 8.2 kg (18 lbs)
- Breakaway force: > 1,200 kg (2,650 lbs) on 15 mm (9/16") S235
- Max. load-bearing capacity with round pipes: 20 - 50 % of the load-bearing capacity on flat material (see TML 500), depending on pipe diameter and material thickness
- Length: 295 mm (11-5/8") (closed lever); width: 118 mm (4-5/8"); height: 216 mm (8-1/2") (open lever)



ALFRA TML 400 R

Prod.-No.
41400.R

MAGNETIC CLAMP TMC 70

Our "little one" with a wide range of applications is the perfect magnetic base for your projects

- 1 Only 0.29 kg (10.2 oz) dead weight
- 2 Up to 70 kg (154 lbs) load-bearing capacity (vertically)
- 3 Easy one-handed operation



Instead of complicated clamping: The TMC 70 for easy fixing of metal parts for welding work

The design of the TMC 70 has one main purpose: to make the magnet a valuable helper for a variety of tasks in your business. For example for special challenges in welding. Among others, the TMC 70 is showing full effort when it comes to fixing ferromagnetic metal sheets and panels – to ensure flawless welding seams. Furthermore the compact magnet is an assistant if you have to weld at an angle or if you have to fix particularly filigree metal parts, which alternatively would have to be fastened with clamps.

Attachment holes on top and three sides are providing, that the TMC 70 is nearly unlimited customizable. The flat design is an advantage, too.

Due to a height of only 25 mm, the magnet is perfectly suitable for the easy integration and attachment of accessories. Like all Alfra-magnets the TMC 70 is characterized by the patented magnetic technology, which is generating the magnetic field in an ideal way. The result: exceptional holding power even on thinwalled materials.

From a material thickness of 3 mm on steel the magnet has a holding force of 60 kg. The smart construction of the activation lever ensures that you are able to use the TMC 70 from three sides, even in narrow angles.

The security mechanism is keeping the magnet reliably in switched-on position. Additionally the smallest of our positioning magnets is especially lightweight and durable because of the aluminum case.

Technical data TMC 70:

- Dead weight: 0.29 kg (10.2 oz)
- Breakaway force: 72 kg (158 lbs) on 6 mm (1/4") steel S235
- Length: 69 mm (2-3/4"); width: 50 mm (2"); height: 25 mm (1")

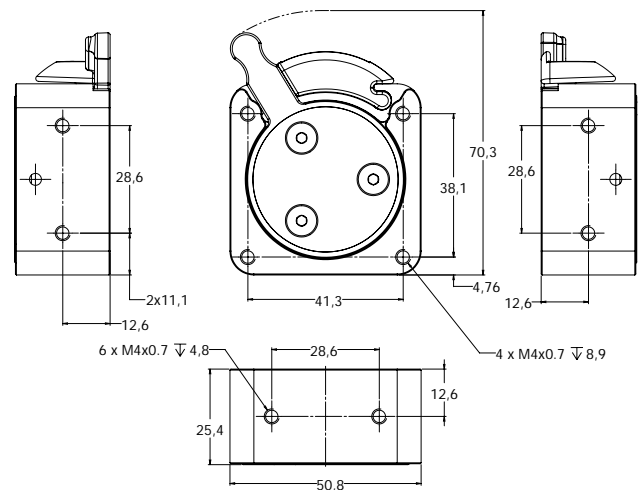

Prod.-No.

ALFRA TMC 70

Accessories: Stainless steel activation lever

41070

189414451

MAGNETIC CLAMP TMC 300

Our “l ittle one” with a wide range of applications is t he perfect magnetic base for your pr ojects

- 1 Only 1 kg (2.2 lbs) dead weight
- 2 Up to 300 kg (660 lbs) load-bearing capacity (vertically)
- 3 Easy one-handed operation



- Excellent holding force up to 300 kg (660 lbs) – even on a steel plate with 6 mm (1/4") thickness only
- User-friendly one-handed operation thanks to ergonomic activation lever
- Connection threads (M5 and M6) on the top and the sides of the TMC 300 allow for the easy attachment of handling accessories such as cutting guides, angle side plates, handles, and much more
- Ideal tool to ease your work, e.g. during levelling of plates, platform construction, fixation, or any kind of clamping technique!
- The specially aligned magnetic field (patented) makes up to approx. 15 mm to the outside of the magnet (9/16") possible
- Wear-resistant magnetic contact area made of hardened steel with TiN-coating preventing damages and guaranteeing a long lifetime
- Exceptional shear force for better hold, especially during vertical applications

Technical data TMC 300:

- Dead weight: 1 kg (2.2 lbs)
- Breakaway force: > 300 kg (660 lbs) on 6 mm (1/4") steel S235
- Length: 82.5 mm (3-1/4"); width: 80 mm (3-1/8"); height: 32.5 mm (1-1/4") (incl. lever: length 190 mm; 7-1/2", width 124 mm; 4-7/8")



Prod.-No.

ALFRA TMC 300

41100

MAGNETIC CLAMP TMC 300 R

R With prism for pipes and curved surfaces
Lifts pipes from 25 mm (1") to 200 mm (7-7/8") in diameter

- 1** Only 1.1 kg (2.4 lbs) dead weight
- 2** Max. Breakaway force: 300 kg (660 lbs)
- 3** Easy one-handed operation



MADE IN GERMANY
US Patent No. 8350663B1

- Excellent holding force on pipes from 25 mm (1") to 200 mm (7-7/8") in diameter
- Outstanding performance on thin-walled materials (operable from just 1 mm; 1/32")
- The specially aligned magnetic field (patented) makes up to approx. 15 mm to the outside of the magnet (9/16") possible
- Wear-resistant magnetic contact area made of hardened steel with TiN-coating preventing damages and guaranteeing a long lifetime

Technical data TMC 300 R:

- Dead weight: 1.1 kg (2.4 lbs)
- Breakaway force: > 300 kg (660 lbs) on 6 mm (1/4") steel S235
- Max. load-bearing capacity with round pipes: 20 - 50 % of the load-bearing capacity on flat material (see TMC 300), depending on pipe diameter and material thickness
- Length: 82.5 mm (3-1/4"); width: 80 mm (3-1/8"); height: 32.5 mm (1-1/4") (incl. lever: length 190 mm; 7-1/2", width 124 mm; 4-7/8")

ALFRA TMC 300 R

Prod.-No.
41100.R

ADJUSTABLE WELDING ANGLE TMA 600

- 1 Only 2.7 kg (6 lbs) dead weight
- 2 Infinitely adjustable from 0° to 90°
- 3 Including two TMC 300 Magnetic Clamps providing a max. holding force of up to 2 x 300 kg (660 lbs) (perpendicular to the magnetic contact area)



MADE IN GERMANY 
US Patent No. 8350663B1



- Highly adjustable angle side plates with a range from 0° to 90° for holding and welding workpieces
- Quick clamping levers for easy fixation/adjusting
- A must have for everyone who needs to weld heavy workpieces together at different angles
- Lightweight, easy and trouble-free handling
- Wear-resistant magnetic contact area made of hardened steel with TiN-coating preventing damages and guaranteeing a long lifetime

Technical data TMA 600:

- Breakaway force: > 300 kg (660 lbs) per TMC 300 on 6 mm (1/4") steel S235
- Shear force: up to 100 kg (220 lbs)
- Dead weight: 2.7 kg (6 lbs)
- Length: 184 mm (7 1/4"); width: 124 mm; 4-7/8"); height: 128 mm (5 1/16") (magnets are parallel)
(with levers, magnets are parallel: length: 249 mm (9 13/16"); width: 180 mm (7 1/16")



▶ VIDEO

ALFRA TMA 600

Prod.-No.

41100.A

SERVICE AND INSPECTIONS CARRIED OUT BY THE MANUFACTURER IN ACCORDANCE WITH LEGAL REQUIREMENTS

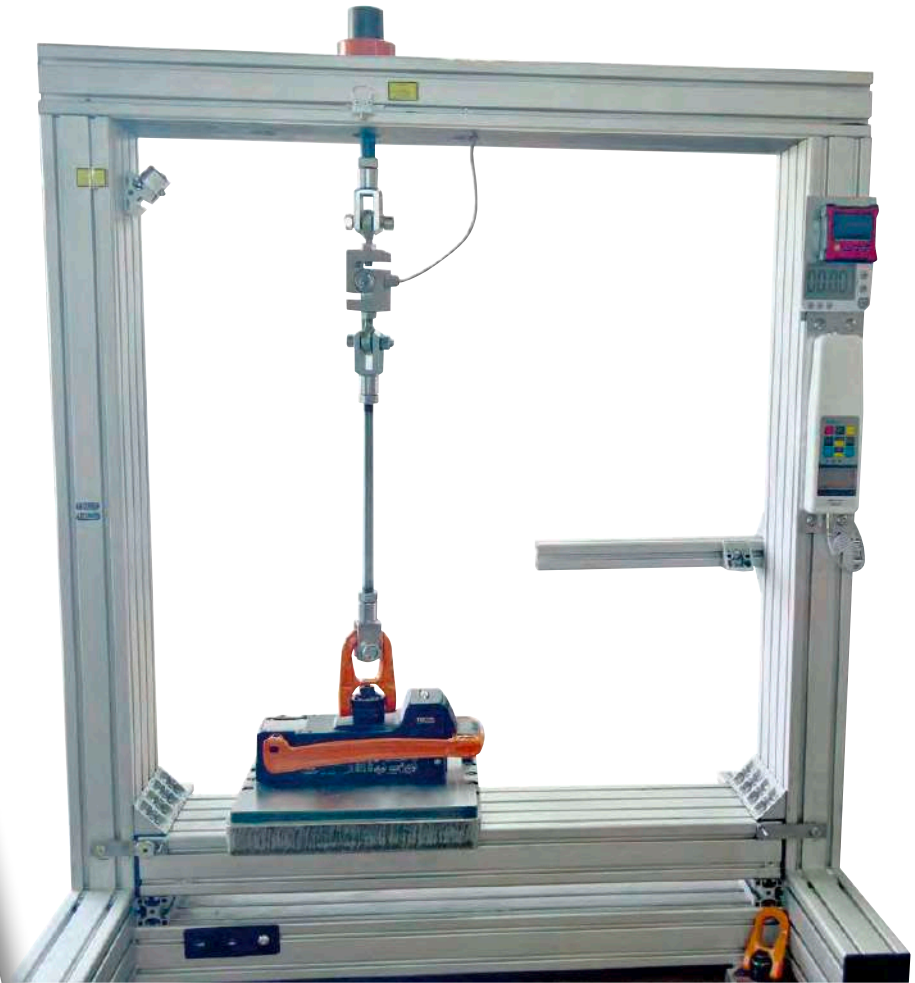

TÜV-CERTIFIED TEST STATION IN OUR MAGNET PRODUCTION

PRODUCT CONTROL CARD

Produkt (product)	TML500
Artikelnummer (product number)	41500
Seriennummer (serial number)	190268

Sichtprüfung inkl. Aufkleber
(visual check incl. sticker)

Lastwirbel mit 50 Nm
(swivel hook with 50 Nm)

Belastungstest 60s bei 1000 kg
(load test 60s at 1000 kg; 2200 lb)

Max. Abriskraft > 1500 kg
(Max. Breakaway force > 1500 kg; 3300 lb)

Test 2-Punkt Deaktivierung
(test 2 point deactivation)

Sichtprüfung Magnetunterplatte
(visual check magnet bottom plate)

Name
(name)

Prüfdatum
(test date)



Despite utmost care in production and application, magnets are subject to constant wear through use and external influences. Therefore, they must not only be maintained regularly, but also tested at certain intervals.

In chapter 2.8 on “Operating load handling attachments in hoisting operations”, the trade association rules BGR 500 stipulate that load handling attachments must be assessed once a year by an expert. (More information on this topic can also be found under point 11 in our FAQs on page 180).

In order to be able to support you in the implementation of this standard in a legally secure, fast and economically sensible way, we are offering you the “Recurring inspection” at first hand.

Our competent design engineers will evaluate your magnet and repair it if necessary. Our expert advisors will be happy to arrange an appointment for you. You are also welcome to write to us at: **TML-Test@alfra.de**

INTERESTING FACTS ABOUT TML/TMC MAGNETS

FREQUENTLY ASKED QUESTIONS

1. What is the unique selling point of the Alfra magnets?

Whether it is a Lifting Magnet, Positioning Magnet or a Welding Angle-magnets made by ALFRA are distinguishable due to their user-friendly design and provide outstanding performance and infinite new application possibilities. The patented magnetic system eliminates scattering losses and the magnet generates an extremely compact magnetic field. A particular highlight is that the magnets are light-weight: A TML or TMC magnet easily and effortlessly achieves a lifting force that conventional lifting magnets can only reach with three times (if at all) the amount of dead weight. Another reason to choose an ALFRA Lifting Magnet is that TML and TMC magnets attain an excellent performance even on thin material—with a minimum thickness of only 1 mm!

2. How do I know how much the magnets can lift?

A clearly arranged graphic can be found on the magnet's label indicating its load-bearing capacity, dependent upon the material's thickness. For detailed information on the load-bearing capacity of TML magnets and the factors that influence it, please refer to the operating instructions of your Lifting Magnet. The TML 250 can for example safely lift 50 kg (195 lbs) of steel at a thickness of 2 mm (1/16") and 240 kg (530 lbs) of steel at a thickness of 8 mm (5/16"). A safety factor of 3:1 is always included. That means that, in fact, the magnet could lift 150 kg (330 lbs) of steel at a thickness of 2 mm (1/16") and 720 kg (1,590 lbs) of steel at a thickness of 8 mm (5/16") without tearing off. The 3:1 safety factor is required by law. Be sure to work within the safety measures of the lifting scale and observe the performance data and safety instructions of the operating manual.

3. What do the terms *residual magnetism* and *pretension* mean?

These terms describe a reduced magnetic field that the magnet generates even when it is not activated. This pretension allows the customer to attach the magnet onto a vertical surface or even over his head and align the magnet without it falling off. Thus, he can move the magnet to the perfect position for an optimum lifting process before pushing the activation lever down.

4. What is an *air gap*?

The small distance that may form between the magnetic contact area and the surface of the work-piece is referred to as an air gap. It may for instance occur due to a deformation of the material during the lifting process. An air gap that is too big will result in the breakaway of the magnet from the material surface. Therefore the entire magnetic contact area should rest on a plane surface of the material being lifted.

5. What is the advantage of the tight-fitting activation lever of the TML 250, 400 R, 500 and 1000?

The activation lever of conventional magnets protrudes at an angle of 90 degrees and sticks out to the side of the magnet—in most cases by several centimeters/inches. For this reason, the magnet can only be attached to areas that are wide enough for the protruding lever.

Due to its user-oriented design, the stable activation lever of the ALFRA TML magnets, TML 250, 400 R, 500 and 1000 rests closely against the magnet housing. As the lever of the TML magnet is parallel to the base body of the magnet, it allows for the easy and effortless attachment of the magnet to narrow areas e.g. between I-beams.

6. Why is the bottom plate of ALFRA magnets hardened and coated?

The magnetic contact area is located on the underside of the magnet. The installed permanent magnets generate an extremely powerful magnetic field to ensure an optimum magnetic adhesion. High-quality, specially hardened steel with approx. 450 HV 30 (approx. 1400N/mm²) prevents damage to the magnetic contact area and protects it from wear and tear. A TiN-coating by means of 2500 HV 0.05 additionally increases the durability of the magnetic contact area. For this reason, ALFRA magnets provide a long service life. Another advantage: the regrinding of the lower plates required with conventional magnets is no longer necessary with the Alfra models of the TML and TMC series.

7. What is a magnetic *shearing stroke*?

The term shearing stroke describes the vertical lifting of a work piece. The most common kind of shearing stroke is the sidelong vertical lifting of steel sheets or thin steel beams from a stack. Due to this, the Lifting Magnet is able to vertically lift the work piece up to 90°. In contrast to conventional magnets, the TML Lifting Magnet even allows for the lifting of a 4 mm (5/32") thick single steel sheet from a stack. This means that the magnet's attractive force will not be exerted onto the subjacent work piece. With an ALFRA TML magnet, the so-called 'sticking together' of two work pieces now belongs in the past.

8. Can rust or paint reduce the magnet's load capacity?

Magnetic Clamps and Lifting Magnets also achieve an excellent adhesive force even on rusty, lacquered or powder-coated surfaces. For detailed information on the performance of your TMC or TML magnet please refer to the operating instructions.

INTERESTING FACTS ABOUT TML/TMC MAGNETS

FREQUENTLY ASKED QUESTIONS

9. What is the impact of extreme temperature on TML/TMC magnets?

Even high temperatures of up to 60°C (140°F) have no impact on the performance of our TML and TMC magnets. At temperatures above 60°C (140°F) or in the event of heat generation near the magnet (e.g. during welding), the integrated high performance permanent magnets may be damaged. For this reason the magnet should be removed from the heat source as quickly as possible. Low temperatures do not decrease the performance of your magnet either since the magnetic molecules align simultaneously in one direction (and thus maintain the magnetic field). Although the magnet slowly loses its lifting power at -150°C (-238°F), the use of TML/TMC magnets at low temperatures must be restricted due to certain components: Components made of aluminum or plastic for example become brittle and may break at a temperature below -30°C (-22°F). The grease does not endure very low temperatures and may become hard. To ensure a long service life and the safety function of your ALFRA magnet, TMC magnets may only be used up to -30°C (-22°F) maximum and TML magnets up to -10°C (14°F) maximum.

10. Why do TML and TMC magnets have different operating temperatures?

The Lifting Magnets TML 250, 400 R, 500 and 1000 are equipped with a special safety tab whose proper function may be limited at very low temperatures. The TML 500 is additionally equipped with a special feature—a hydraulic damper. Thanks to the integrated variable damper the user can adjust the recoil energy according to the desired requirements. As the oil inside the damper loses its viscosity with decreasing temperature, the magnet must not be used below -10°C (14°F). TML and TMC models without a safety tab and variable damper may still operate up to -30°C (-22°F).

11. Does the magnet require examination after a certain period of time?

Lifting accessories such as our TML magnets must be checked regularly. This includes particularly an annual inspection of the triple safety factor. Maintenance and care of the magnets are subject to country-specific regulations and standards. In Germany regular inspections are prescribed by sec.3, subs.3 of the German Ordinance on Industrial Safety and Health (BetrSichV). The examination of the triple safety factor must be performed once a year by a competent person according to the German Trade Association Regulation BGR 500. The operator is responsible for the adherence to the regular inspection of the magnet. Always observe the regulations in your country. Clamping Magnets such as the TMC 300 must not be used for the lifting or transportation of loads and thus do not require an annual examination.

12. Who is allowed to perform the inspection?

According to the Trade Association Regulation 500 (chapter 2.8: sec.3.15), the employer determines the requirements that the person carrying out the inspection must fulfill ('competent person').

They can be experts such as engineers, machine and crane foremen or specially trained persons provided that they possess adequate knowledge as well as sufficient experience of slings and lifting accessories and are familiar with the relevant national occupational health and safety regulations, trade association regulations and generally accepted rules of technology (e.g. BGR regulations, DIN- EN-standards, DIN-standards, ISO standards). Furthermore, the examination of the triple safety factor for the Lifting Magnet requires a special pull-off unit which is equipped with calibrated test equipment.

We would be happy to perform the inspection of your ALFRA lifting accessories for you at our premises.

13. Can loads also be lifted vertically?

Due to the innovative ALFRA Magnetic System, the vertical lifting of loads is no longer a problem. In particular, the TML 400 R, 500 and 1000 are excellent devices to lift

components vertically. The magnet's load swivel (also called load hook) is pulled up vertically by means of a flexible soft eye, following the direction of the force action, and lies close to the level housing of the TML magnet.

14. Which forces act during a vertical lift?

There are some particularities to note in terms of the vertical lifting of loads. If the load and the magnet surface tilt at an angle other than 0° to horizontal, the load-bearing capacity

decreases due to the new alignment of the magnet to the gravity of Earth. As soon as the load is suspended vertically, i.e. at an angle of 90°, friction will be the only effect exerted by the magnet. Depending on the material being lifted this is not more than 10 - 35% of the maximum load-bearing capacity.

Further information on the use of TML magnets during pivoting or vertical lifting can be found in the operation manual of your ALFRA magnet. All information and safety instructions contained in the operation manual must be closely observed.

15. Are the magnets only suitable for the lifting of loads?

The wide range of ALFRA magnets includes a multitude of applications that go far beyond the lifting of loads. For example, TML magnets are ideally suited to shearing loads. Moreover, magnets made by ALFRA also represent the ideal tools to facilitate your work if you want to align, position or join ferromagnetic workpieces.

Do you like animated pictures?

Discover exciting application videos on the Alfra homepage at www.alfra.de

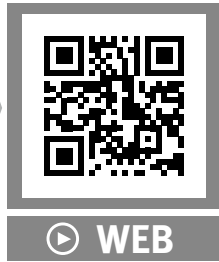

or visit our **Youtube-Channel „alfratools“**.
<https://www.youtube.com/user/alfratools>



We wish you much joy and success when using our products.

Your Alfra GmbH

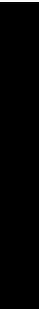

TECHNICAL INFORMATION

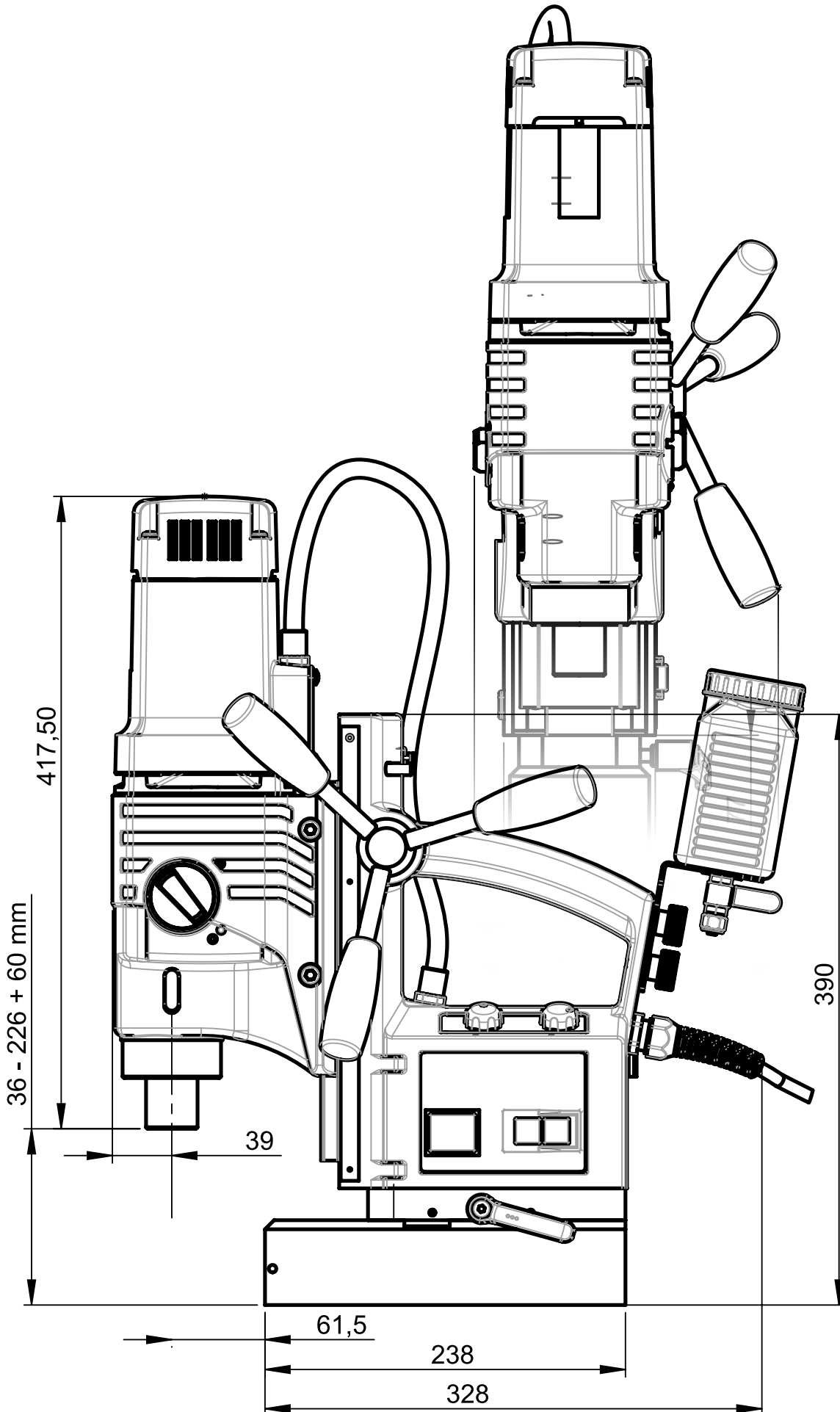

MACHINE DIMENSIONING – ALFRA ROTABEST®

RB 35 B

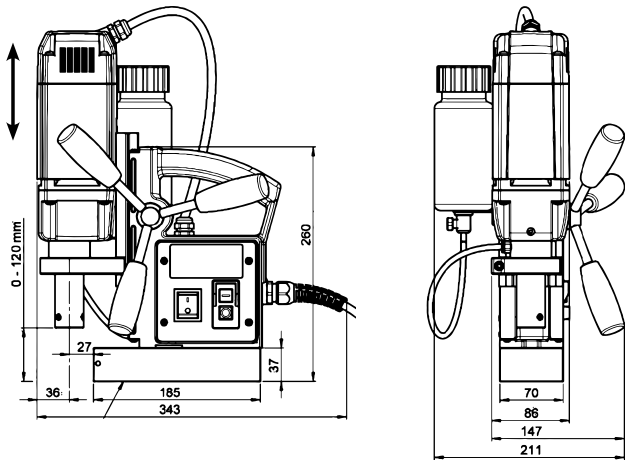

RB 35/50 B Piccolo

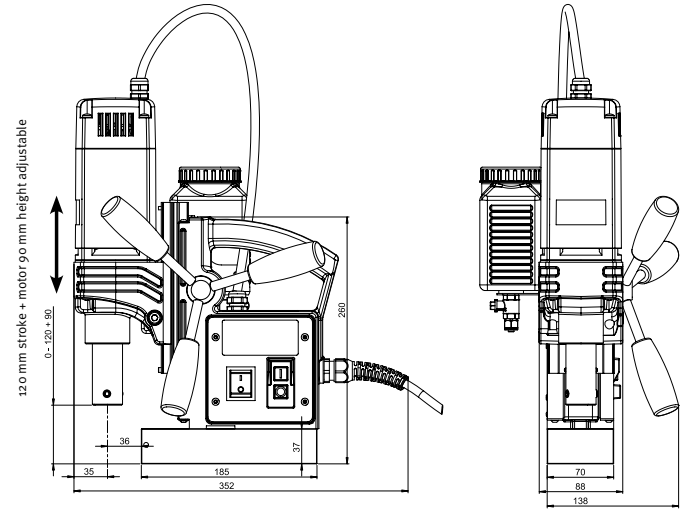

RB 50 B

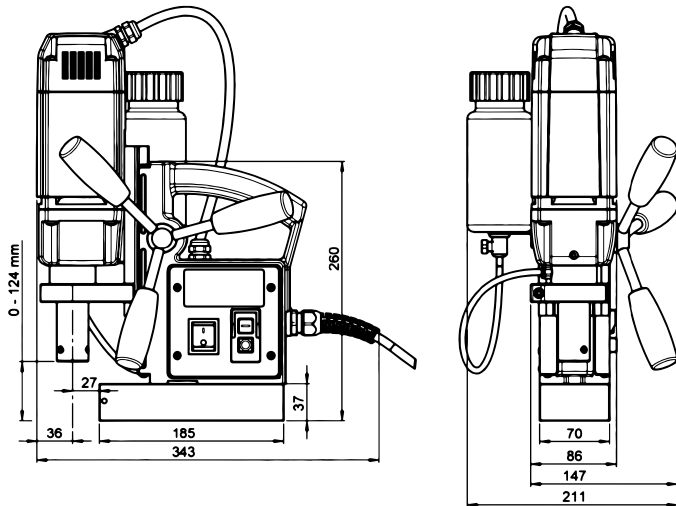

RB 80 B

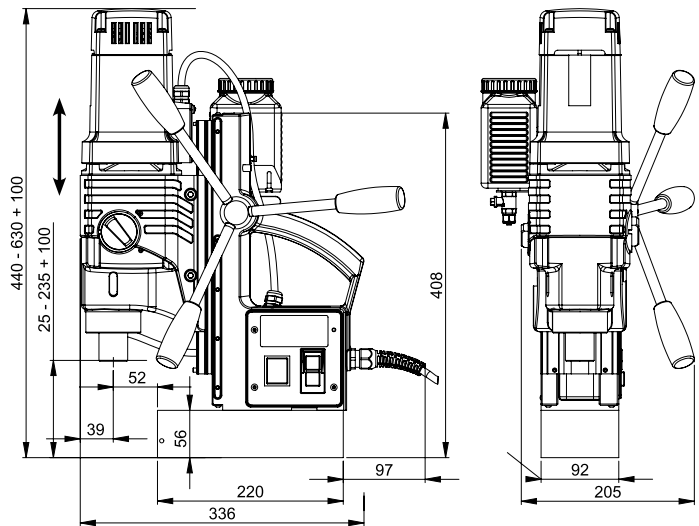

RB 130 B + 130 B RL-E

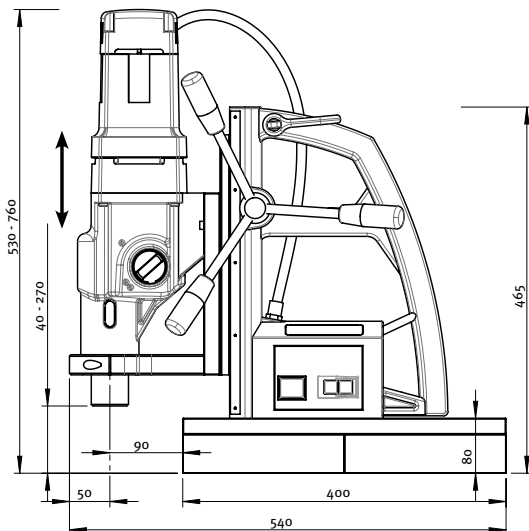

RB 50 B RL-E

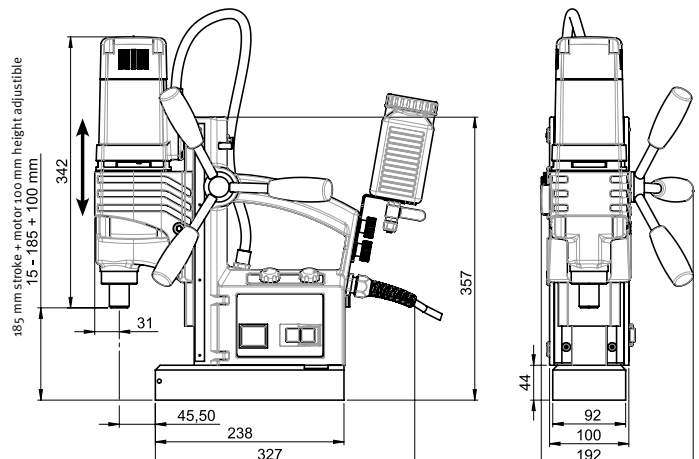

MACHINE DIMENSIONING – ALFRA ROTABEST®

RB 80 B RL-E

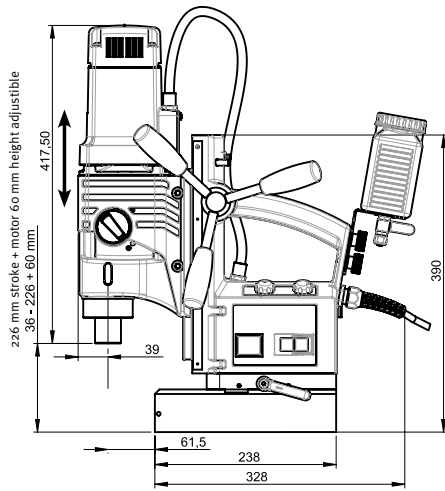

RB 100 B RL-E

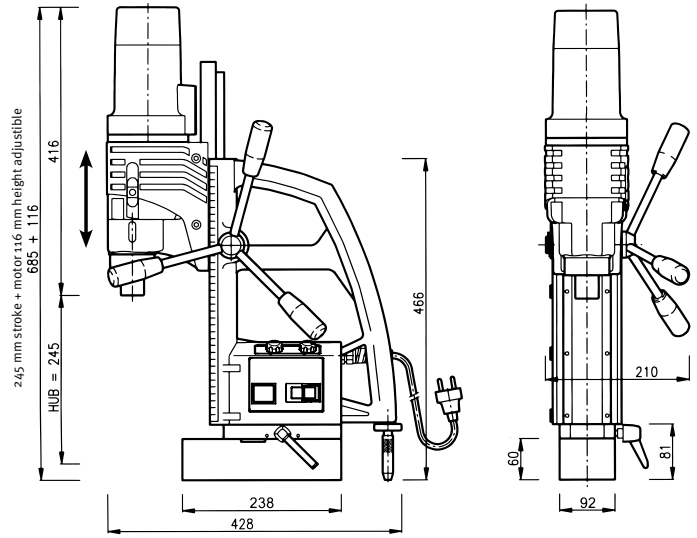

RB 35 SP

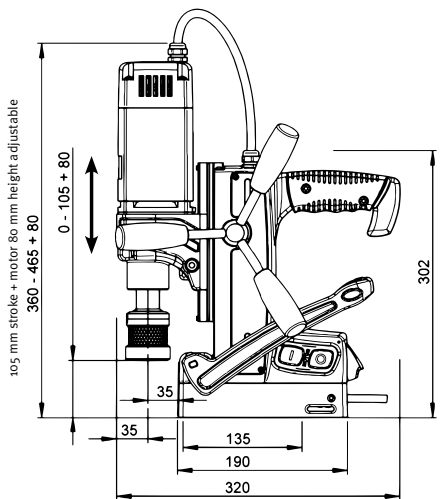

RB 50 SP

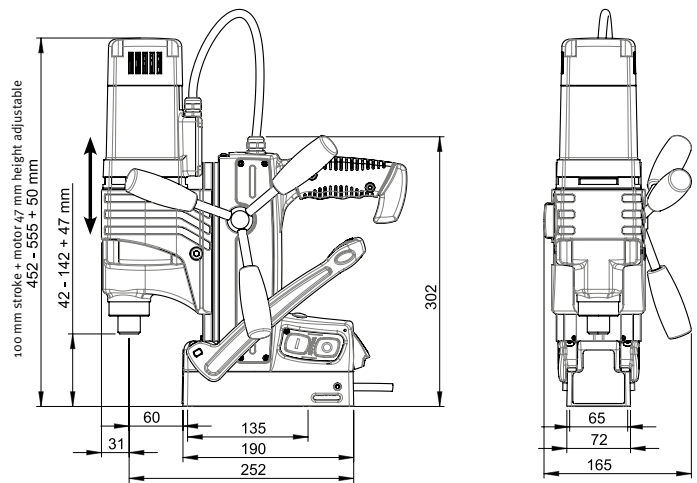

SP-V

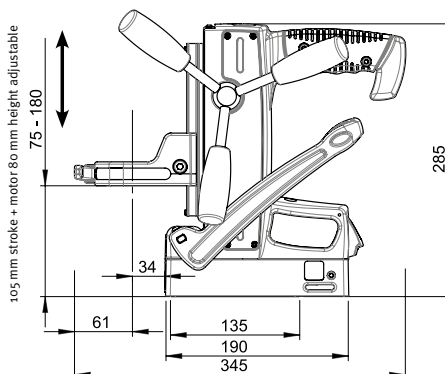

V 40

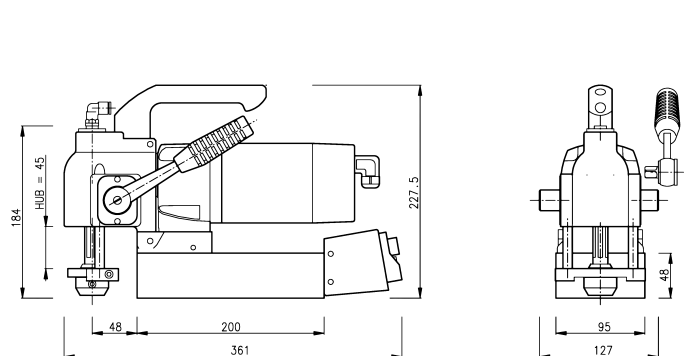

THE CORE DRILL PRINCIPLE

Metal core drilling in Germany was introduced by ALFRA

- Core drills only machine a fraction of the material which a twist drill machines with the same bore diameter.
- A drill core remains which is ejected unmachined after drilling.
- Therefore low drive power and feeding pressure are required.
- Pre-drilling must be done with twist drills which does not apply for core drilling and the desired diameter can be drilled directly.

The main drilling times are significantly reduced depending on the bore diameter.



Savings on machining volume of a core drill compared to a twist drill!

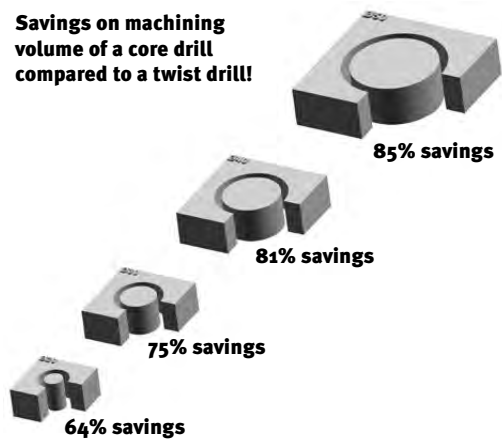

ALFRA CORE DRILLS – SPEED OVERVIEW

FOR HSS AND HSS-CO CORE DRILLS



Material	unalloyed steel Up to 700 N/mm ²	alloyed steel Up to 1000 N/mm ²	aluminium alloy
Vc=m/min	30	20	30
Cooling lubricant	Cutter oil	Cutting oil	Cutting oil
Ø mm	Ø "	rpm	rpm

FOR TCT CORE DRILLS



Material	unalloyed steel Up to 700 N/mm ²	alloyed steel Up to 1000 N/mm ²	aluminium alloy
Vc=m/min	50	35	60
Cooling lubricant	Cutter oil	Cutting oil	Cutting oil
Ø mm	Ø "	rpm	rpm

Not suitable for automatic feed!

12	15/32	796	531	796
13	33/64	735	490	735
14	35/64	682	455	682
15	19/32	637	425	637
16	5/8	597	398	597
17	43/64	562	375	562
18	45/64	531	354	531
19	3/4	503	335	503
20	25/32	478	318	478
21	53/64	455	303	455
22	7/8	434	290	434
23	29/32	415	277	415
24	15/16	398	265	398
25	63/64	382	255	382
26	1 1/32	367	245	367
27	1 1/16	354	236	354
28	1 3/32	341	227	341
29	1 9/64	329	220	329
30	1 3/16	318	212	318
31	1 7/32	308	205	308
32	1 17/64	299	199	299
33	1 19/64	290	193	290
34	1 11/32	281	187	281
35	1 3/8	273	182	273
36	1 27/64	265	177	265
37	1 29/64	258	172	258
38	1 1/2	251	168	251
39	1 17/32	245	163	245
40	1 37/64	239	159	239
41	1 39/64	233	155	233
42	1 21/32	227	152	227
43	1 11/16	222	148	222
44	1 47/64	217	145	217
45	1 25/32	212	142	212
46	1 13/16	208	138	208
47	1 55/64	203	136	203
48	1 57/64	199	133	199
49	1 15/16	195	130	195
50	1 31/32	191	127	191
60	2 3/8	159	106	159

Not suitable for automatic feed!

18	45/64	885	619	1062
19	3/4	838	587	1006
20	25/32	796	557	955
21	53/64	758	531	910
22	7/8	724	507	869
23	29/32	692	485	831
24	15/16	663	464	796
25	63/64	637	446	764
26	1 1/32	612	429	735
27	1 1/16	590	413	708
28	1 3/32	569	398	682
29	1 9/64	549	384	659
30	1 3/16	531	372	637
31	1 7/32	514	360	616
32	1 17/64	498	348	597
33	1 19/64	483	338	579
34	1 11/32	468	328	562
35	1 3/8	455	318	546
36	1 27/64	442	310	531
37	1 29/64	430	301	531
38	1 1/2	419	293	503
39	1 17/32	408	286	490
40	1 37/64	398	279	478
41	1 39/64	388	272	466
42	1 21/32	379	265	455
43	1 11/16	370	259	444
44	1 47/64	362	253	434
45	1 25/32	354	248	425
46	1 13/16	346	242	415
47	1 55/64	339	237	407
48	1 57/64	332	232	398
49	1 15/16	325	227	390
50	1 31/32	318	223	382
55	2 5/32	290	203	347
60	2 3/8	265	186	318
65	2 9/16	245	171	294
70	2 3/4	227	159	273
75	2 61/64	212	149	255
80	3 5/32	199	139	239
85	3 11/32	187	131	225
90	3 35/64	177	124	212
95	3 47/64	168	117	201
100	3 15/16	159	111	191

When drilling Hardox, we recommend using TCT Rail core drills. Use pure cutting oil for the drilling of Hardox and reduce the speed by 10% appr., as in the column "Alloyed steel up to 1000 N/mm²". Use only magnetic drills with high holding force or column drilling and milling machines.

TAPPING – RECOMMENDED VALUES (TOLERANCE ACCORDING TO ISO 2 6H)

RECOMMENDED VALUES FOR USE OF MACHINE TAP DRILLS WITH TAPPING ATTACHMENTS ON MAGNETIC DRILLS

Tapping: The tap drill to be used must be matched to the core hole prepared in the work piece. Please refer to the enclosed borehole table for metric ISO threads.

Borehole table metric ISO threads

Dimensions	Stg.	Drill Ø
M3	0.5	2.5
M4	0.7	3.3
M5	0.8	4.2
M6	1	5
M8	1.25	6.8
M10	1.5	8.5
M12	1.75	10.2
M14	2	12
M16	2	14
M18	2.5	15.5
M20	2.5	17.5

Fine thread

Dimensions	Stg.	Drill Ø
M8x1	1	7
M10x1	1	9
M12x1	1	11
M12x1.5	1.5	10.5
M14x1	1	13
M14x1.5	1.5	12.5
M16x1	1	15
M16x1.5	1.5	14.5
M20x1	1	19
M20x1.5	1.5	18.5

Tips for the production of threads

1. Clearance hole

We recommend adjacent tap drills for the clearance holes which convey the chips out of the borehole in the cutting direction. The special polished section also allows a reliable re-threading when the tap drill is withdrawn from the tapped hole and moves back in an anticlockwise direction.

2. Blind holes

We recommend adjacent tap drills for blind holes. The chips are guided out of the borehole against the direction of the cutting. It is particularly important to ensure that the tap drill does not run aground, because otherwise the automatic return can no longer be activated. A correspondingly large pre-borehole depth must be planned.

If this is not done, the tap drill must be loosened manually.

3. Blind holes up to 1.5 x D

For this, our tap drills are suited to according to the adjacent figure. Also here, the chips are conveyed away out of the borehole against the cutting direction. Also here, it must be ensured that the tap drill does not run aground. A correspondingly large pre-borehole depth must be taken into account.

If this is not done, the tap drill must be loosened manually.

Beside our tap drills with a reinforced shank, tap drills with a reduced shaft according to DIN 376 can, of course, also be used.

Please work with sufficient coolant that is recommended by the manufacturer for tapping.

Chip ejection downward through the hole

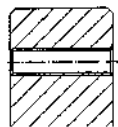

DIN 371 with a reinforced shank form B, with spiral point, 3.5 to 5 pitches

DIN 376 with a reduced shaft, thread depth 3 x D

Chip ejection along the tool

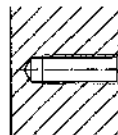

DIN 371 with reinforced shank with a spiral groove, approx. 35° right-hand twist bevel C, approx. 3 pitches

DIN 376 with reduced shaft Thread depth 2.5 x D

Chip ejection along the tool

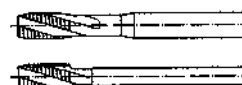
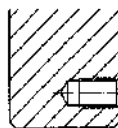

DIN 371 with reinforced shank with a spiral groove, approx. 17° right-hand twist, bevel C, approx. 2 to 3 pitches

DIN 376 with reduced shaft Thread depth 1.5 x D

TCT TOOLS – TECHNICAL TERMS

Clearance angle

is the angle between the carbide teeth and the material to be machined. ALFRA TCT core drills have several clearance angles on a cutting edge.

Cutting depth

is the maximum material thickness that can be machined with the respective tool (should not be confused with the construction height of the tool).

Chip flute

gathers up the chips generated or removes these from the borehole.

Chip breaker

directs the chips from the carbide tooth into the chip flute.

Cutting face

the chip is formed on this surface.

Angle of rake

is the angle between the tool axis and the cutting face.

Tooth projection

is the carbide projection to the core.

Tooth height difference

is used for the chip splitting.

Speed, cutting speed and feed rate (typical values)

Rotabest®- TCT hole cutters

Not suitable for automatic feed

Material	m/min	mm/r
Construction steel 50 kp/m ²	40-60	0.08-0.12
Steel 50-70 kp/m ²	30-50	0.08-0.12
Stainless steel	18-45	0.8-0.10
Cast iron	65-95	0.12-0.20
Non-ferrous metals, aluminium	100-550	0.22-0.45
Exotic alloys	10-30	0.05-0.08

Accuracy (reference value) / Input / + 0.10 mm Output / ± 0 mm

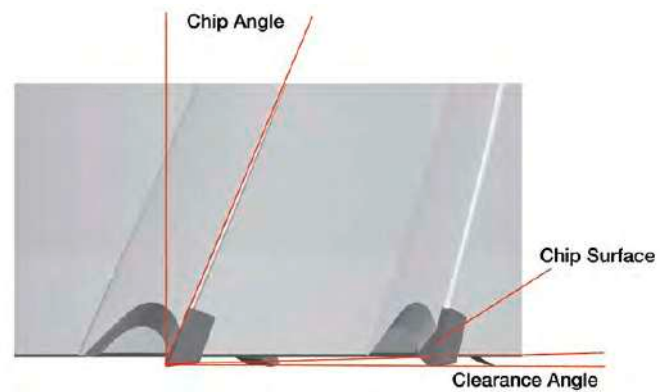

TCT-HOLE SAWS – SPEED CHART

Speed calculation

n = Speed (1/min)

v_c = Cutting Speed (m/min)

d = Tool diameter (mm)

$$n = \frac{v_c \times 1000}{d \cdot \pi}$$

Worked sample:

d = 20 mm

v_c = 50 m/min

$$n = \frac{50000}{20 \cdot \pi} = 795,77 \text{ 1/min}$$

Tool Ø	Cutting speed m/min													
	Stainless steel material							Mild steel - ST material						
	20	25	30	35	40	45	50	55	60	65	70	75	80	
16	398	498	597	697	796	896	995	1095	1194	1294	1393	1493	1592	
18	354	442	531	619	708	796	885	973	1062	1150	1238	1327	1415	
20	318	398	478	557	637	717	796	876	955	1035	1115	1194	1274	
22	290	362	434	507	579	651	724	796	869	941	1013	1086	1158	
24	265	332	398	464	531	597	663	730	796	863	929	995	1062	
26	245	306	367	429	490	551	612	674	735	796	857	919	980	
28	227	284	341	398	455	512	569	626	682	739	796	853	910	
30	212	265	318	372	425	478	531	584	637	690	743	796	849	
32	199	249	299	348	398	448	498	547	597	647	697	746	796	
34	187	234	281	328	375	422	468	515	562	609	656	703	749	
36	177	221	265	310	354	398	442	487	531	575	619	663	708	
38	168	210	251	293	335	377	419	461	503	545	587	629	670	
40	159	199	239	279	318	358	398	438	478	518	557	597	637	
42	152	190	227	265	303	341	379	417	455	493	531	569	607	
44	145	181	217	253	290	326	362	398	434	470	507	543	579	
46	138	173	208	242	277	312	346	381	415	450	485	519	554	
48	133	166	199	232	265	299	332	365	398	431	464	498	531	
50	127	159	191	223	255	287	318	350	382	414	446	478	510	
52	122	153	184	214	245	276	306	337	367	398	429	459	490	
54	118	147	177	206	236	265	295	324	354	383	413	442	472	
56	114	142	171	199	227	256	284	313	341	370	398	427	455	
58	110	137	165	192	220	247	275	302	329	357	384	412	439	
60	106	133	159	186	212	239	265	292	318	345	372	398	425	
62	103	128	154	180	205	231	257	283	308	334	360	385	411	
64	100	124	149	174	199	224	249	274	299	323	348	373	398	
66	97	121	145	169	193	217	241	265	290	314	338	362	386	
68	94	117	141	164	187	211	234	258	281	304	328	351	375	
70	91	114	136	159	182	205	227	250	273	296	318	341	364	
72	88	111	133	155	177	199	221	243	265	288	310	332	354	
74	86	108	129	151	172	194	215	237	258	280	301	323	344	
76	84	105	126	147	168	189	210	230	251	272	293	314	335	
78	82	102	122	143	163	184	204	225	245	265	286	306	327	
80	80	100	119	139	159	179	199	219	239	259	279	299	318	
82	78	97	117	136	155	175	194	214	233	252	272	291	311	
84	76	95	114	133	152	171	190	209	227	246	265	284	303	
86	74	93	111	130	148	167	185	204	222	241	259	278	296	
88	72	90	109	127	145	163	181	199	217	235	253	271	290	
90	71	88	106	124	142	159	177	195	212	230	248	265	283	
92	69	87	104	121	138	156	173	190	208	225	242	260	277	
94	68	85	102	119	136	152	169	186	203	220	237	254	271	
96	66	83	100	116	133	149	166	182	199	216	232	249	265	
98	65	81	97	114	130	146	162	179	195	211	227	244	260	
100	64	80	96	111	127	143	159	175	191	207	223	239	255	



FRP Hole Saws

Ø mm	Timber Chipboard	Plastics	Masonry	Wall tiles*
25/30/35	1000	800	800	500
40/45/50	800	600	700	400
58 bis 74	600	400	600	400
80/105	400	300	300	300

* Drilling in tiles only up to a scratch hardness of 6, mark centre, set the centre drill and drill through the glaze with at a low speed, allow the saw teeth to penetrate the glazing uniformly, running as smoothly and level as possible, so that the edge of the hole is made without chipping. Continue drilling at a normal drilling speed. Tiles with a scratch hardness greater than 6 may only be cut with diamond or carbide hole saws.

Notes on use

- Use rotation only. Switch off impact or hammer drill.
- Impact and shock on the sharp, ground carbide cutters can lead to small carbide splinters and thus to a severe loss of performance.
- Do not tilt the hole saw in the hole.
- Remove the drill core after each operation. Remove the sawdust when drilling timber and timber products.

Notes on use

- For multipurpose hole saw with rim countersink
- The rim countersink is placed between hole saw and adapter and the carbide cutter is used to make a countersink in timber and timber substitutes. This makes it possible to fit sockets flush.

Important notes on use

- The hole saw with rim countersink may not be stopped before it is removed.
- Advance with care, to prevent the cut edges tearing.

HSS BI METAL HOLE SAWS – NOTES ON USE

1. Use the hole saws at the recommended cutting speed, see guide table on the packaging.
2. Do not apply excess pressure. Apply a little more pressure for a harder material and less pressure for a softer material.
3. In order to achieve good centring, the centre drill must project approximately 6 mm beyond the teeth. It is recommended that the hole is first predrilled with a twist drill and then the centre drill is used in the adapter as a centring pin.
4. Use a good cutting oil when drilling metal. This extends the hole saw's service life and prevents premature blunting of the tooth tips.
5. The arbor of the adapter must be firmly clamped with the flattened sides correctly seated in the chuck.
6. The hole saw must cut into the workpiece at a right angle. Avoid tilting. Risk of accident.
7. If large hole saw diameters are used in hand-held drills, the hand-held drill must be held particularly firmly. A drill stand should be used where possible.
8. The adapter must be firmly screwed into the hole saw with all its thread and the driver pins must be firmly seated in the driver holes.
9. Secure the driver pins with the rotating ring or lock in the case of a quick-change adapter.
10. Wear protective goggles when working with the bi-metal hole saws and keep hands away in case saw runs out. Never attempt to stop with your hands a saw that is running off.
11. Lift the saw clear frequently, especially when cutting timber, chipboard and wood substitutes and remove the sawdust and chips. If this is not done, the tooth tips can burn and the hole saw will jam in the cut.
12. We recommend the following procedure when drilling timber, chipboard and wood substitutes:

Drill a number of holes immediately inside the cut. This helps carry the chips away and avoids frequent interruptions in cutting to clean the tooth tips.

If the workpiece is especially thick...

...it is also recommended that you cut from both sides, or drill a number of holes immediately inside the circular cut. This helps carry the chips away and avoids frequent interruptions in cutting to clean the tooth tips.

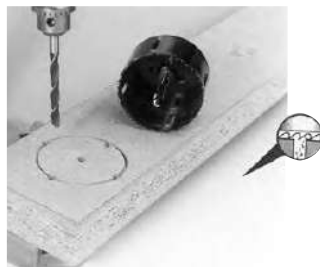

Enlarging existing holes

Existing holes 32 mm (1-1/4") or more in diameter may be enlarged with a simple trick:



Take a 32 mm diameter hole saw and screw this inside the hole saw on the projecting thread of the A2 adapter. The inner hole saw then acts as a kind of guiding hole saw for extending existing holes, see photo.

What you absolutely must avoid:

1. Drilling at too fast or too slow a cutting speed. The teeth will glide over the material and become prematurely blunt.
2. Avoid bringing the saw teeth abruptly down on the workpiece, the teeth will break off.
3. Never cut metallic materials dry. Always use a cutting oil.
4. Never bring the saw up to the workpiece on a slant. There is a risk of injury when hand drills are used. The saw can break up or the arbor could be damaged.
5. Ensure that the hole saw is running true. Check the chuck as necessary.
6. Never screw the adapter's guide pins only partially into the hole saw guide holes. The thread of the hole saw could be torn out.
7. Never regrind the hole saw freely by hand. Have hole saws reground by a specialist. Care must be taken to ensure sufficient residual setting and a uniform tooth height.
8. If the tool arbor is pushed into the chuck or if the arbor shears off, the advance pressure is too great.
9. If the hole saw is unevenly worn on the outside, then the saw is not running true or the material to be sawn was not correctly clamped.
10. If the tooth tips are blued, the saw has been used without cutting oil, or at too high a cutting speed.

HSS BI-METAL HOLE SAWS – SPEED CHART

Diameter mm	Mild Steel	Cast Iron	Tool steel + stainless steels	Brass	Aluminium	Wood
14	580	400	300	790	900	3000
16	550	365	275	730	825	3000
17	500	330	250	665	750	3000
19	460	300	230	600	690	3000
20	440	290	220	580	660	3000
21	425	280	210	560	635	3000
22	390	260	195	520	585	3000
24	370	245	185	495	555	3000
25	350	235	175	470	525	2700
27	325	215	160	435	480	2700
29	300	200	150	400	450	2700
30	285	190	145	380	425	2400
32	275	180	140	380	410	2400
33	260	175	135	345	390	2400
35	250	165	125	330	375	2400
37	240	160	120	315	360	2400
38	230	150	115	300	345	2400
40	220	145	110	290	330	2100
41	210	140	105	280	315	2100
43	205	135	100	270	305	2100
44	195	130	95	260	295	2100
46	190	125	95	250	285	2100
48	180	120	90	240	270	2100
51	170	115	85	230	255	2000
52	165	110	80	220	245	2000
54	160	105	80	210	240	2000
57	150	100	75	200	225	2000
59	145	100	75	195	225	2000
60	140	95	70	190	220	2000
64	135	90	65	180	205	1800
65	130	85	65	175	200	1800
67	130	85	65	170	195	1800
70	125	80	60	160	185	1800
73	120	80	60	160	180	1800
76	115	75	55	150	170	1500
79	110	70	55	140	165	1500
83	105	70	50	140	155	1500
86	100	65	50	130	150	1200
89	95	65	45	130	145	1200
92	95	60	45	120	140	1200
95	90	60	45	120	135	1200
98	90	60	45	120	135	1200
102	85	55	40	110	130	1000
105	80	55	40	110	120	1000
108	80	55	40	110	120	900
111	80	50	40	100	120	900
114	75	50	35	100	105	900
121	75	50	35	95	95	900
127	65	45	30	90	90	800
133	60	40	25	86	85	800
140	60	40	25	85	85	800
146	55	35	25	75	75	800
152	55	35	25	75	75	800



These speeds are benchmarks. The speed can be higher or lower, this depends on the material type and the cutting behaviour.

Attention: Do not use cutting oil, if you are cutting cast iron. If you are cutting aluminium use paraffin wax or paraffin.

Calculation of the Cutting Speed

n = Speed (1/min)

v_c = Cutting speed (m/min)

d = Tool diameter (mm)

$$v_c = \frac{\pi \times d \times n}{1000}$$

PUNCHING UNITS APS 70/120 – USAGE INSTRUCTIONS

From the field, questions continue to be asked about the material thickness / hole diameter ratio ($S/D = \emptyset$ ratio).

Intermediate material thickness and the smallest hole or punch diameter must be a certain ratio.

A specific ratio must exist between material thickness and the lowest hole or punch die \emptyset .

An old rule of thumb is that the punch die must be as big or even bigger than the thickness of the material to be cut. The material thickness must be but never be greater than the punch die \emptyset .

This rule no longer applies to our hydraulic punching units.

They are still used with fast-working, mechanical presses because the process takes place abruptly and the punch is loaded to the utmost.

For our ALFRA APS punching units, the punching process is carried out slowly and gently.

In this case, holes can also be punched the diameter of which is less than the thickness of the material to be cut.

Chart 1 clarifies the right thickness/diameter ratio. This is based on trials such as.:

Holes are to be punched in a steel plate made of S235. What is the recommended ratio?

The shear strength of S235 is about 30 kg/mm². At 30, move vertically upwards in the chart to line A, from there to the left to the S/D diameter ratio scale.

Result: The recommended ratio is 1:1.3.

The **upper limit** of the ratio is the dotted line B which specifies a ratio of 1:1.7. This would mean that the thickness of the material to be cut may be 1.7 times larger than the diameter of the punch die.

It goes without saying that the life expectancy of a punch with this diameter ratio should be considerably shorter than one with a ratio of 1: 1.3.

We therefore recommend only working to line A so that sufficient reliability exists.

Diameter of the punched holes/material thickness

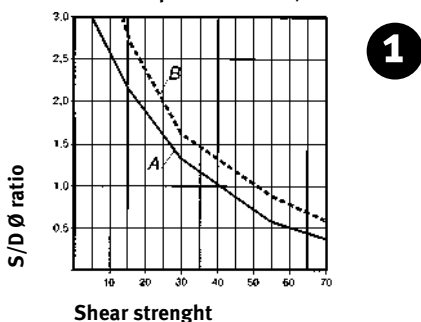

Minimal punch die \emptyset with existing material thickness

With Chart 2, the smallest hole punch \emptyset can be easily determined.

Three varieties of material with different strength options are specified.

Another example:

Holes to be punched in a steel plate with a thickness of 20 mm made of S235. How large may the smallest punch die \emptyset be?

On the horizontal scale for material thickness, move vertically upward at 20 mm to the full line of S235. Then horizontally to the left up to the scale of the punch die \emptyset .

Result: = 15 mm \emptyset .

To get the breaking point of the stamp, move up to the second line.

It is therefore advisable only to proceed according to the first method.

ALFRA punch dies and matrices are made from high quality material. Nevertheless, it may happen that a stamp breaks.

This is caused by:

1. S/D diameter ratio is not correct.
2. The material to be punched is not lying straight but wedged on the matrix.
3. The punching unit or the material is moved greatly during the punching process.
4. If the scraper is damaged or not properly set to the height, the material can be wedged when the punch die retracts.
5. The scraper is located too far from the punch die so that thin sheet metal bulges when scraping. In this case, the punch die breaks in flakes at the cutting edge.

In this case, we recommend providing the scraper with a bridge or possibly using a special change guide.

We hope that you work easily and reliably with the ALFRA Press punch units with these usage instructions.

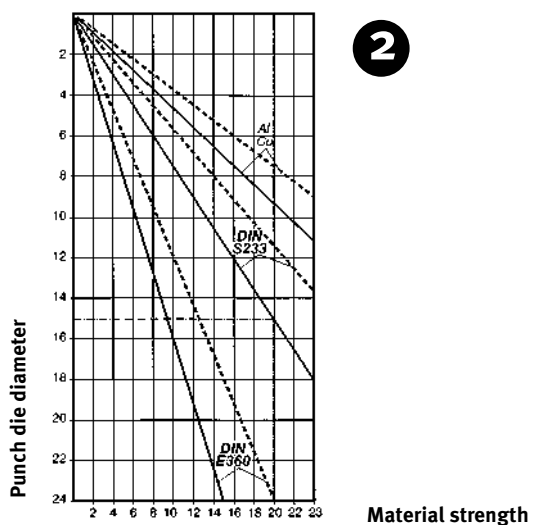

ALFRA PUNCHING UNITS APS – WORKING AREA

Material St. 42

	Material strength mm Material DIN S233	Force needed for punching [kN] (10 kN... approximately 1 ton) • Punch diameter (mm)																					
		7	8	9	10	11	12	13	14	15	16	17	18	19	20	21	22	23	24	25	26	27	28
APS 70 (DIN S275)	3	25	28	32	35	39	43	46	50	53	57	60	64	67	71	74	78	82	85	89	92	96	99
	4	33	38	43	47	52	57	61	66	71	76	80	85	90	94	99	104	109	113	118	123	128	132
	5	41	47	53	59	65	71	77	83	89	94	100	106	112	118	124	130	136	142	148	154	159	165
	6	50	57	64	71	78	85	92	99	106	113	120	128	135	142	149	156	163	170	177	184	191	198
	7	58	66	74	83	91	99	107	116	124	132	141	149	157	165	174	182	190	198	207	215	223	232
	8		76	85	94	104	113	123	132	142	151	161	170	180	189	198	208	217	227	236	246	255	265
	9			96	106	117	128	138	149	159	170	181	191	202	213	223	234	245	255	266	276	287	298
	10				118	130	142	154	165	177	189	201	213	224	236	248	260	272	283	295	307	319	331
	11					143	156	169	182	195	208	221	234	247	260	273	286	299	312	325	338	351	364
	12						170	184	198	213	227	241	255	269	283	298	312	326	340	354	369	383	397
APS 120 (DIN S275)	13							200	215	230	246	261	276	292	307	322	338	353	369	384	399	415	430
	14								232	248	265	281	298	314	331	347	364	380	397	413	430	447	463
	15									266	283	301	319	337	354	372	390	408	425	443	461	478	496
	16										302	321	340	359	378	397	416	435	454	472	491	510	529
	17											341	361	382	402	422	442	462	482	502	522	542	562
	18												383	404	425	447	468	489	510	532	553	574	595

Actual punching force

APS 60 70 120 70D 110D
in kN 225 313 470 454 508

Rm max (sheets)
Tau max = 0.85 * Rm max
coef. (Steel X / DIN S233)

DIN S233	DIN S275	DIN S355	DIN E335	C 25	C 35	C 45	C 60
470	510	630	710	600	700	800	900
376	408	504	568	480	560	640	720
1.00	1.09	1.34	1.51	1.28	1.49	1.70	1.91

Example 1: Punching unit APS 70, F max 454 = kN
Punch diameter Ø=20 mm
Material thickness T = 8 mm
Material C 45, R_m max=800 N/mm²

Example 2: Punching unit APS 70, F max = kN 313
Punch diameter Ø = 21 mm
Material thickness T = 12 mm
Material DIN S275, R_m max=510 N/mm²

Calculation 1: F = F(DIN S233) * coef.(C 45/DIN S233)
F = 189 * 1.70 = 321.3 kN
F is less than F max, punch force sufficient

Calculation 2: F = F(DIN S233) * coef.(DIN S275/DIN S233)
F = 298 * 1.09 = 324.8 kN
F is greater than F max;
Punch power is not sufficient;
Please opt for our APS 120

CONVERSION – PRESSURE

- Pascal (pa) = 1 Newton (N)/m²
- 1 Bar (bar) = 10 to the power of 5 Pa = 10 to the power of 5 N/m² = 10 N/m² = 750.06 mercury column
- 1 bar = 1.019 kg/cm² = 0.1 N/mm² = 14.5 psi
- 1 kg/cm² (atm) = 0.981 bar = 0.0981 N/mm² = 14.2234 psi
- 1 bar = 1.02 technical atmospheres (at) = 1.02 kg/cm² = 10 N/cm²
- 1 physical atmosphere (atm) = 1.013 bar = 1.033 kg / cm² = 760 mm mercury column = 760 torr
- 1 torr = 1.332 mbar
- 1 m water column (mH₂O, = 0.0980665 bar)
- 1 mm H₂O = 0.0980665 mbar = 9.80655 Pa
- 1 N/mm² = 10 bar = 10.19 kg/cm² = 145 psi
- 1 psi = 0.069 bar = 0.0703 kg/cm² = 0.0069 N/mm²

CONVERSION TABLE – PRESSURE UNITS

Convert the pressure units “bar” and “psi”

bar	psi	psi	bar
1	14.5	1	0.068965517
10	145	100	6.896551724
100	1450	100	6.896551724
500	7250	5000	344.8275862
1000	14500	10000	689.6551724
1200	17400	10500	724.137931

Copyright by Alfra GmbH
2025

All technical data, descriptions and illustrations contained in this catalogue are not binding. We reserve the right to make changes in the course of the further development of the products.

We accept no liability for printing errors.

Through publication of this catalogue all previous catalogues become invalid.

As of July 2025

All rights reserved.

This catalogue has been prepared with the utmost care. All technical data and information was checked before going to press.

Due to the continuous improvement and development of the ALFRA programme, we reserve the right to modify products from this catalogue or if necessary, also remove them from our product range. For this reason, technical data and products contained in this catalogue may differ - without notice.

Full or partial use and reproduction of this catalogue (drawings, pictures, texts, logos) are prohibited without written permission.

Photo credits:

www.fotolia.com, www.123rf.com, www.gettyimages.com

